

HD74AC174

Hex D-Type Flip-Flop with Master Reset

HITACHI

ADE-205-376 (Z)
1st. Edition
Sep. 2000

Description

The HD74AC174 is a high-speed hex D flip-flop. The device is used primarily as a 6-bit edge-triggered storage register. The information on the D inputs is transferred to storage during the Low-to-High clock transition. The device has a Master Reset to simultaneously clear all flip-flops.

Feature

- Outputs Source/Sink 24 mA

Pin Arrangement

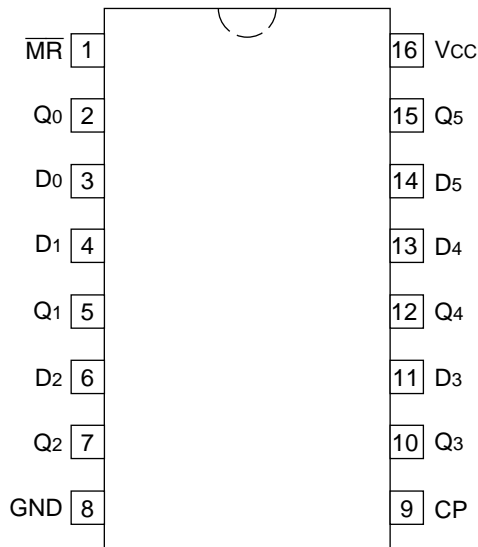

(Top view)

Logic Symbol

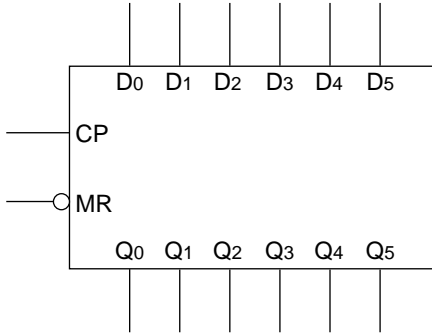



Pin Names

- D₀ to D₅ Data Inputs
- CP Clock Pulse Input
- $\overline{\text{MR}}$ Master Reset Input
- Q₀ to Q₅ Outputs

Functional Description

The HD74AC174 consists of six edge-triggered D flip-flops with individual D inputs and Q outputs. The Clock (CP) and Master Reset ($\overline{\text{MR}}$) are common to all flip-flops. Each D input's state is transferred to the corresponding flip-flop's output following the Low-to-High Clock (CP) transition. A Low input to the Master Reset ($\overline{\text{MR}}$) will force all outputs Low independent of Clock or Data inputs. The HD74AC174 is useful for applications where the true output only is required and the Clock and Master Reset are common to all storage elements.

Truth Table

Inputs			Output
$\overline{\text{MR}}$	CP	D	Q
L	X	X	L
H		H	H
H		L	L
H	L	X	Q

H : High Voltage Level

L : Low Voltage Level

X : Immaterial

 : Low-to-High Transition of Clock

Logic Diagram

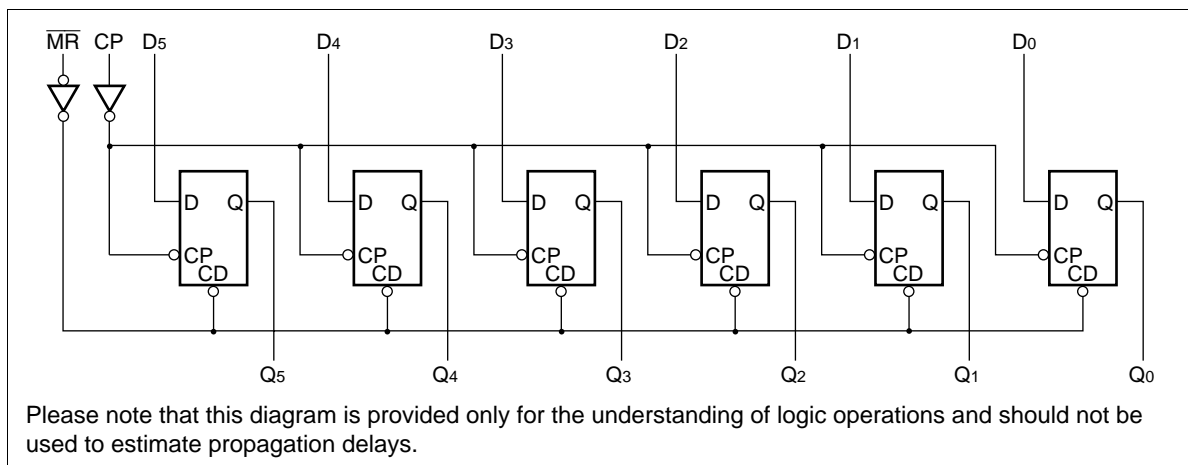

DC Characteristics (unless otherwise specified)

Item	Symbol	Max	Unit	Condition
Maximum quiescent supply current	I_{CC}	80	μA	$V_{IN} = V_{CC}$ or ground, $V_{CC} = 5.5\text{ V}$, $T_a = \text{Worst case}$
Maximum quiescent supply current	I_{CC}	8.0	μA	$V_{IN} = V_{CC}$ or ground, $V_{CC} = 5.5\text{ V}$, $T_a = 25^\circ\text{C}$

AC Characteristics: HD74AC174

Item	Symbol	$V_{CC} (\text{V})^{*1}$	$T_a = +25^\circ\text{C}$ $C_L = 50\text{ pF}$			$T_a = -40^\circ\text{C to } +85^\circ\text{C}$ $C_L = 50\text{ pF}$		Unit
			Min	Typ	Max	Min	Max	
Maximum clock frequency	f_{max}	3.3	90	100	—	70	—	MHz
		5.0	100	125	—	100	—	
Propagation delay CP to Q_n	t_{PLH}	3.3	1.0	9.0	11.5	1.0	12.5	ns
		5.0	1.0	6.0	8.5	1.0	9.5	
Propagation delay CP to Q_n	t_{PHL}	3.3	1.0	8.5	11.0	1.0	12.0	ns
		5.0	1.0	6.0	8.0	1.0	9.0	
Propagation delay $\overline{\text{MR}}$ to Q_n	t_{PHL}	3.3	1.0	9.0	11.5	1.0	12.5	ns
		5.0	1.0	7.0	9.0	1.0	10.5	

Note: 1. Voltage Range 3.3 is $3.3\text{ V} \pm 0.3\text{ V}$
Voltage Range 5.0 is $5.0\text{ V} \pm 0.5\text{ V}$

HD74AC174

AC Operating Requirements: HD74AC174

Item	Symbol	V _{CC} (V)*1	Ta = +25°C C _L = 50 pF		Ta = -40°C to +85°C C _L = 50 pF		Unit
			Typ	Guaranteed Minimum	Guaranteed Minimum	Guaranteed Minimum	
Setup time, HIGH or LOW	t _{SU}	3.3	2.5	6.5	7.0	ns	
D _n to CP		5.0	2.0	5.0	5.5		
Hold time, HIGH or LOW	t _H	3.3	1.0	3.0	3.0	ns	
D _n to CP		5.0	0.5	3.0	3.0		
\overline{MR} pulse width, LOW	t _w	3.3	1.0	5.5	7.0	ns	
		5.0	1.0	5.0	5.0		
CP pulse width	t _w	3.3	1.0	5.5	7.0	ns	
		5.0	1.0	5.0	5.0		
Recovery time	t _{rec}	3.3	0	2.5	2.5	ns	
\overline{MR} to CP		5.0	0	2.0	2.0		

Note: 1. Voltage Range 3.3 is 3.3 V ± 0.3 V
Voltage Range 5.0 is 5.0 V ± 0.5 V

Capacitance

Item	Symbol	Typ	Unit	Condition
Input capacitance	C _{IN}	4.5	pF	V _{CC} = 5.5 V
Power dissipation capacitance	C _{PD}	85.0	pF	V _{CC} = 5.0 V

Package Dimensions

Unit: mm

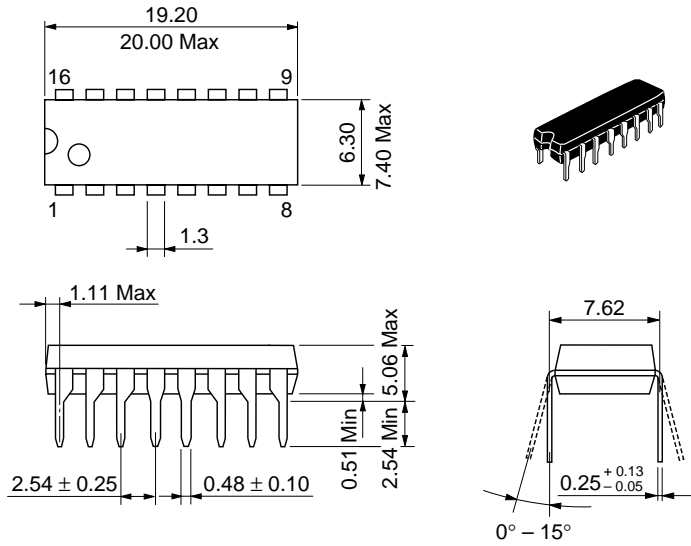

Hitachi Code	DP-16
JEDEC	Conforms
EIAJ	Conforms
Mass (reference value)	1.07 g

Unit: mm

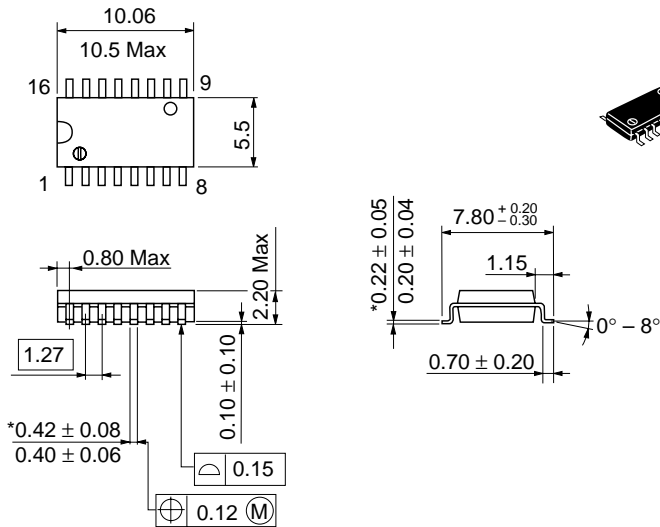

Hitachi Code	FP-16DA
JEDEC	—
EIAJ	Conforms
Mass (reference value)	0.24 g

*Dimension including the plating thickness
Base material dimension

Unit: mm

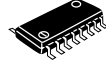
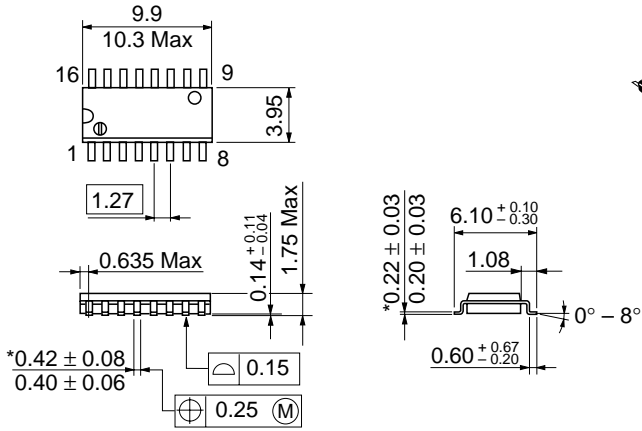

*Dimension including the plating thickness
Base material dimension

Hitachi Code	FP-16DN
JEDEC	Conforms
EIAJ	Conforms
Mass (reference value)	0.15 g

Unit: mm

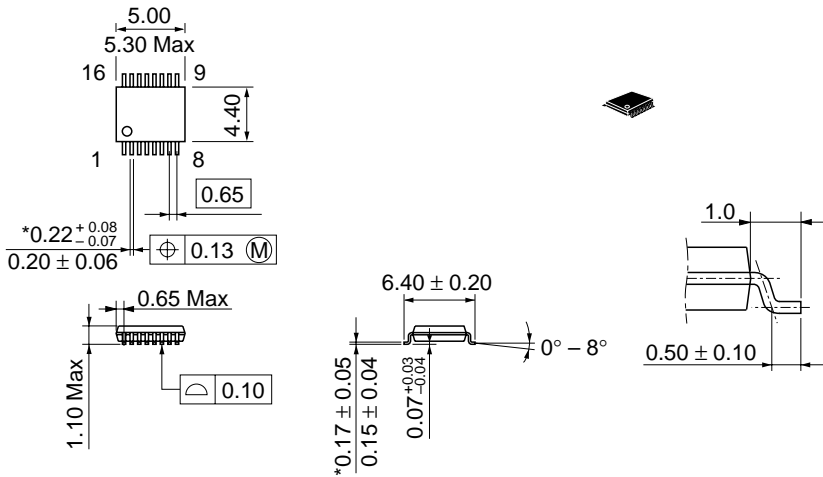

*Dimension including the plating thickness
Base material dimension

Hitachi Code	TTP-16DA
JEDEC	—
EIAJ	—
Mass (reference value)	0.05 g

Cautions

1. Hitachi neither warrants nor grants licenses of any rights of Hitachi's or any third party's patent, copyright, trademark, or other intellectual property rights for information contained in this document. Hitachi bears no responsibility for problems that may arise with third party's rights, including intellectual property rights, in connection with use of the information contained in this document.
2. Products and product specifications may be subject to change without notice. Confirm that you have received the latest product standards or specifications before final design, purchase or use.
3. Hitachi makes every attempt to ensure that its products are of high quality and reliability. However, contact Hitachi's sales office before using the product in an application that demands especially high quality and reliability or where its failure or malfunction may directly threaten human life or cause risk of bodily injury, such as aerospace, aeronautics, nuclear power, combustion control, transportation, traffic, safety equipment or medical equipment for life support.
4. Design your application so that the product is used within the ranges guaranteed by Hitachi particularly for maximum rating, operating supply voltage range, heat radiation characteristics, installation conditions and other characteristics. Hitachi bears no responsibility for failure or damage when used beyond the guaranteed ranges. Even within the guaranteed ranges, consider normally foreseeable failure rates or failure modes in semiconductor devices and employ systemic measures such as fail-safes, so that the equipment incorporating Hitachi product does not cause bodily injury, fire or other consequential damage due to operation of the Hitachi product.
5. This product is not designed to be radiation resistant.
6. No one is permitted to reproduce or duplicate, in any form, the whole or part of this document without written approval from Hitachi.
7. Contact Hitachi's sales office for any questions regarding this document or Hitachi semiconductor products.

HITACHI

Hitachi, Ltd.

Semiconductor & Integrated Circuits.
Nippon Bldg., 2-6-2, Ohte-machi, Chiyoda-ku, Tokyo 100-0004, Japan
Tel: Tokyo (03) 3270-2111 Fax: (03) 3270-5109

URL NorthAmerica : <http://semiconductor.hitachi.com/>
 Europe : <http://www.hitachi-eu.com/hel/ecg>
 Asia : <http://sicapac.hitachi-asia.com>
 Japan : <http://www.hitachi.co.jp/Sicd/indx.htm>

For further information write to:

Hitachi Semiconductor
(America) Inc.
179 East Tasman Drive,
San Jose, CA 95134
Tel: <1> (408) 433-1990
Fax: <1> (408) 433-0223

Hitachi Europe GmbH
Electronic Components Group
Dornacher Straße 3
D-85622 Feldkirchen, Munich
Germany
Tel: <49> (89) 9 9180-0
Fax: <49> (89) 9 29 30 00

Hitachi Europe Ltd.
Electronic Components Group.
Whitebrook Park
Lower Cookham Road
Maidenhead
Berkshire SL6 8YA, United Kingdom
Tel: <44> (1628) 585000
Fax: <44> (1628) 585160

Hitachi Asia Ltd.
Hitachi Tower
16 Collyer Quay #20-00,
Singapore 049318
Tel: <65>-538-6533/538-8577
Fax : <65>-538-6933/538-3877
URL : <http://www.hitachi.com.sg>

Hitachi Asia Ltd.
(Taipei Branch Office)
4/F, No. 167, Tun Hwa North Road,
Hung-Kuo Building,
Taipei (105), Taiwan
Tel: <886>-(2)-2718-3666
Fax : <886>-(2)-2718-8180
Telex : 23222 HAS-TP
URL : <http://www.hitachi.com.tw>

Hitachi Asia (Hong Kong) Ltd.
Group III (Electronic Components)
7/F., North Tower,
World Finance Centre,
Harbour City, Canton Road
Tsim Sha Tsui, Kowloon,
Hong Kong
Tel : <852>-(2)-735-9218
Fax : <852>-(2)-730-0281
URL : <http://www.hitachi.com.hk>

Copyright © Hitachi, Ltd., 2000. All rights reserved. Printed in Japan.
Colophon 2.0

HITACHI