

Simple 90V 20mA Temperature Compensated Constant Current LED Driver IC

Features

- ❑ 5.0V to 90V operating range (V_{a-b})
- ❑ 20mA $\pm 5\%$ at 45V V_{a-b}
- ❑ $-8.5\mu\text{A} / ^\circ\text{C}$ Typical Temperature Coefficient
- ❑ SOT-89, D-PAK & TO-92 packages
- ❑ No external components (two terminal device)
- ❑ Can be paralleled for higher current

General Description

The Supertex CL1 is a high voltage, temperature compensated, constant current source. The device is trimmed to provide a constant current of 20mA $\pm 5\%$ at an input voltage of 45V. No external components are required. The device can be used as a two terminal constant current source or constant current sink.

A typical application for the CL1 is to drive LEDs with a constant current of 20mA. They can also be used in parallel to provide higher currents such as 40mA, 60mA or 80mA. The device is available in SOT-89, D-PAK and TO-92 packages.

**Not Recommended
For New Designs!
See CL2 Datasheet
for more information.**

Applications

- ❑ LED driver
- ❑ Industrial lamp indicators
- ❑ Signage
- ❑ Accent lighting
- ❑ Automotive
- ❑ Constant current source
- ❑ Constant current sink

Typical Application Circuit

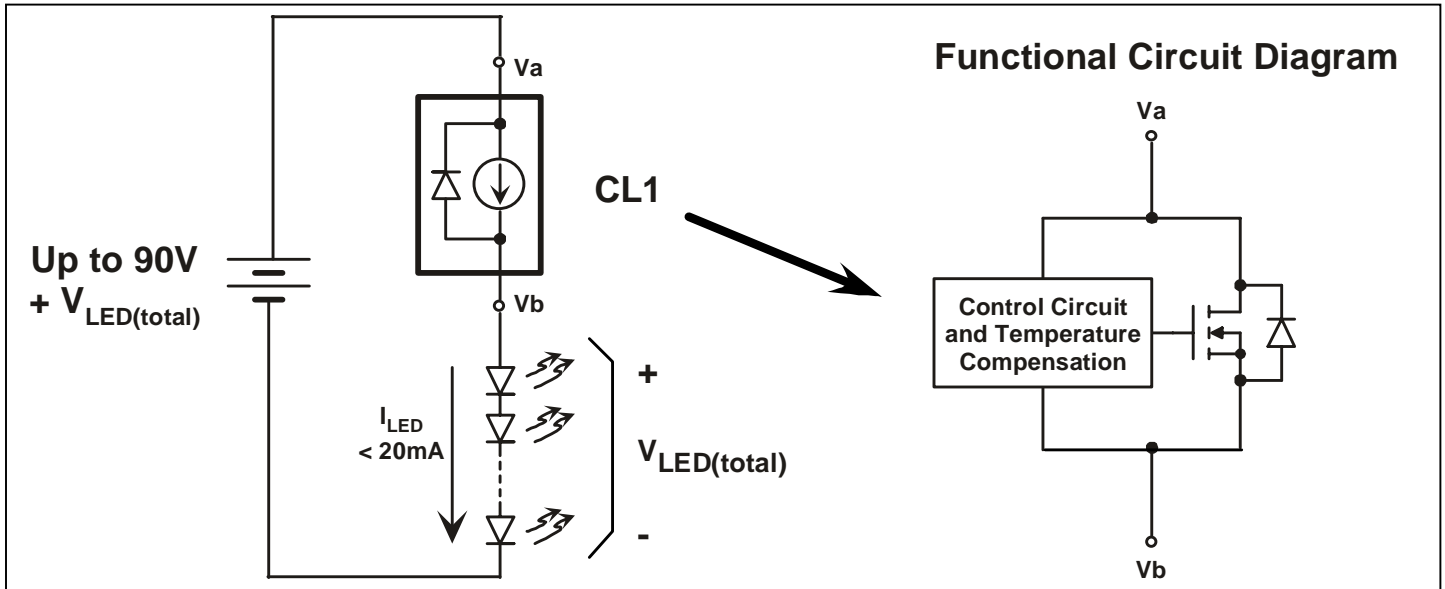

Ordering Information

Order Number / Package		
TO-92	D-PAK	TO-243AA
CL1N3 /CL1N3-G	CL1K4-G	CL1N8 /CL1N8-G

-G indicates package id RoHS compliant ("Green")



Thermal Characteristics

Package	Power Dissipation @ T _A =25°C	θ _{JC} °C/W	θ _{JA} °C/W
TO-92	0.73W	125	170
TO-243AA (SOT-89)	1.3W*	15	78*
TO-252 (D-PAK)	2.0W*	6.0	50*

* Mounted on FR4 board; 25mm x 25mm x 1.57mm.

Absolute Maximum Ratings*

V _{a-b} , Operating Voltage	100V
T _J , Operating Junction Temperature	0°C to +125°C
T _s , Storage Temperature	-55°C to +150°C

*Absolute Maximum Ratings are those values beyond which damage to the device may occur. Functional operation under these conditions is not implied. Continuous operation of the device at the absolute rating level may affect device reliability.

Package Options

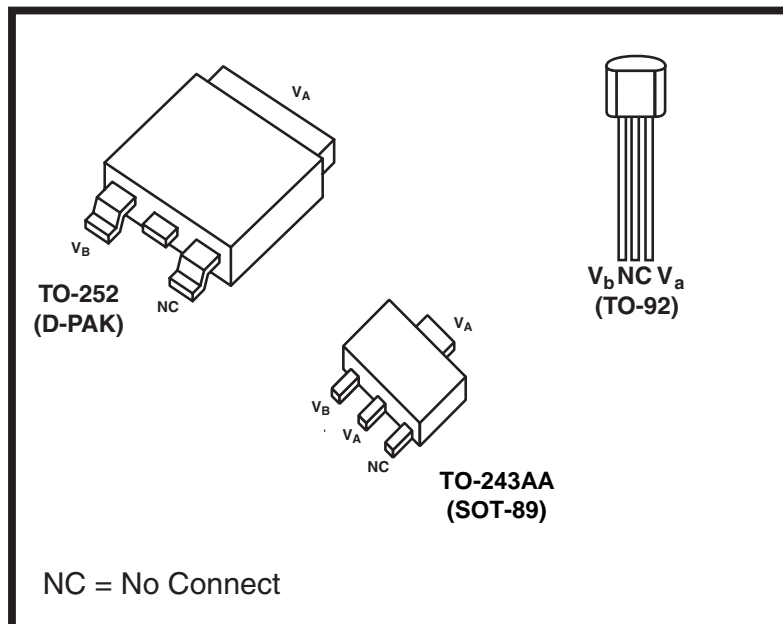

Electrical Characteristics (@ $T_J=25^\circ\text{C}$ unless otherwise specified)

Symbol	Parameter	Min	Typ	Max	Units	Conditions
Va-b	Maximum operating voltage			90	V	
Ia-b	Current regulation	17.1	18.0	18.9	mA	Va-b=5V
		19.0	20.0	21.0	mA	Va-b=45V
		19.0	22.0	24.2	mA	Va-b=90V
$\Delta I_{a-b}/\Delta T$	Ia-b temperature coefficient		-8.5		$\mu\text{A}/^\circ\text{C}$	Va-b=45V, $T_J=0^\circ\text{C}$ to 100°C
Ra-b	AC resistance		17		K Ω	Va-b=5.0V to 90V
T_J	Operating junction temperature	0		125	$^\circ\text{C}$	

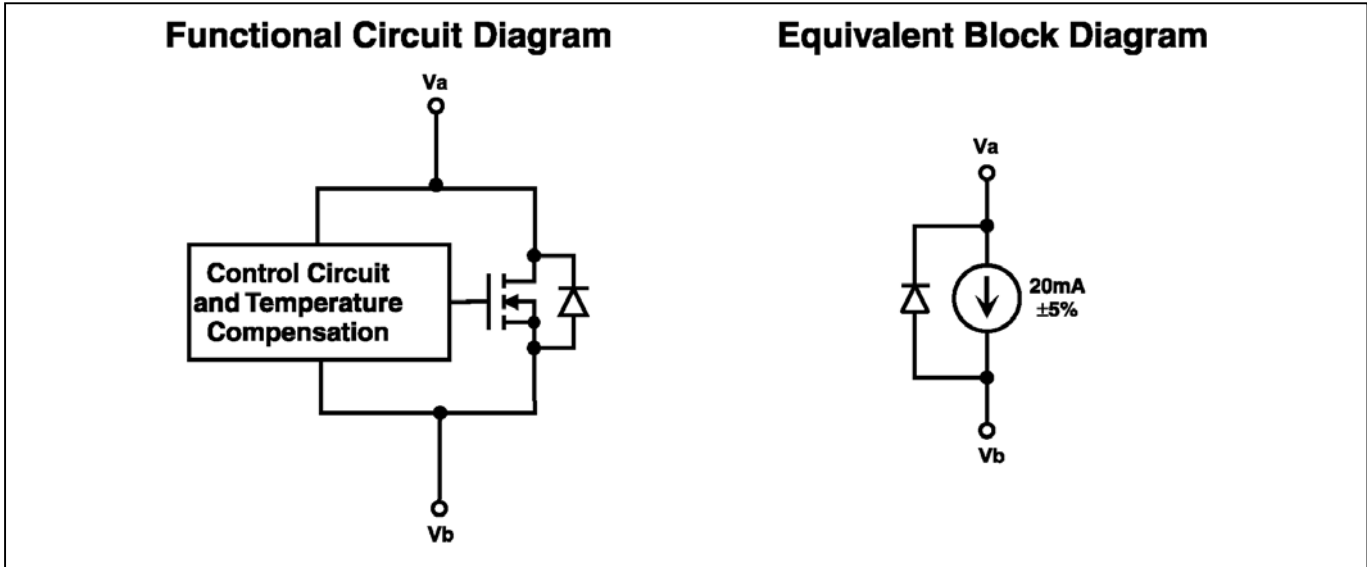

Output Current vs Voltage

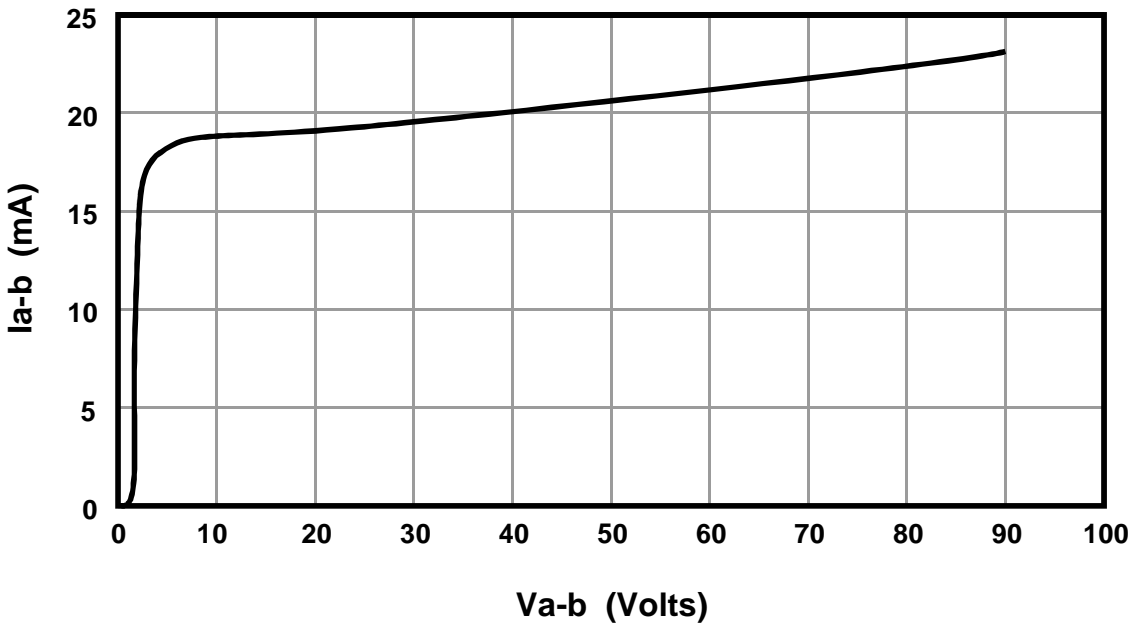

CL1 for 120V Off-Line LED Driver

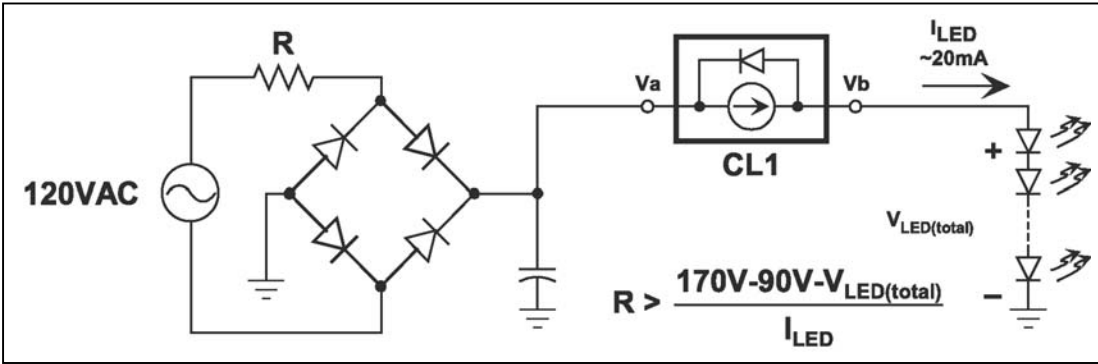

CL1 for Multiple LED Strings

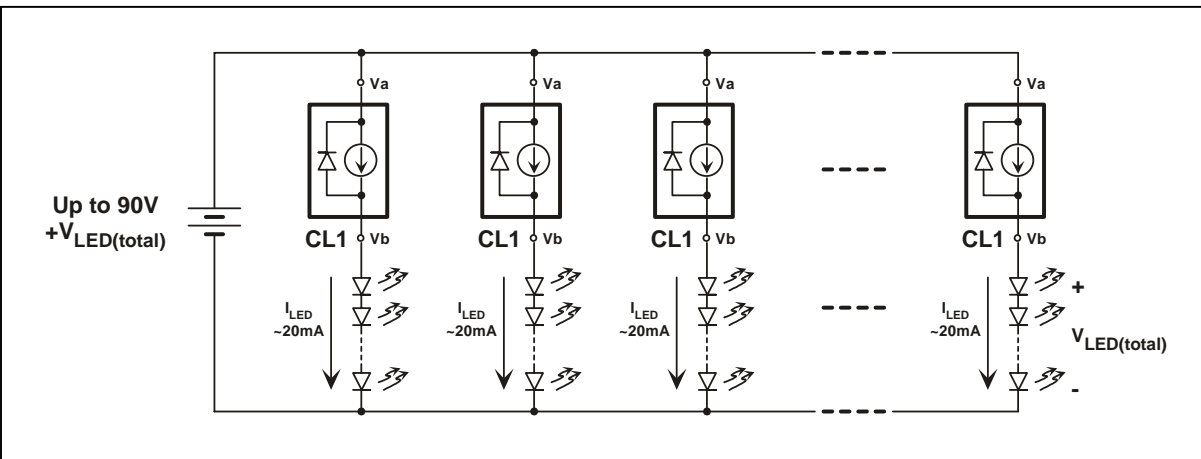

CL1 for 120V Off-Line LED Driver

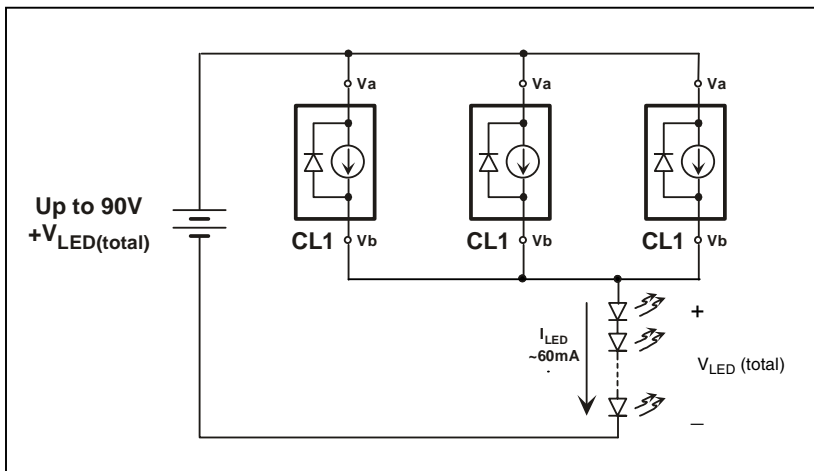

Supertex Inc. does not recommend the use of its products in life support applications and will not knowingly sell its products for use in such applications unless it receives an adequate "products liability indemnification insurance agreement." Supertex does not assume responsibility for use of devices described and limits its liability to the replacement of devices determined to be defective due to workmanship. No responsibility is assumed for possible omissions or inaccuracies. Circuitry and specifications are subject to change without notice. For the latest product specifications, refer to the Supertex website: <http://www.supertex.com>. For complete liability information on all Supertex products, refer to the most current databook or to the Legal/Disclaimer page on the Supertex website.

3-Lead TO-252 D-PAK Package Outline (K4)

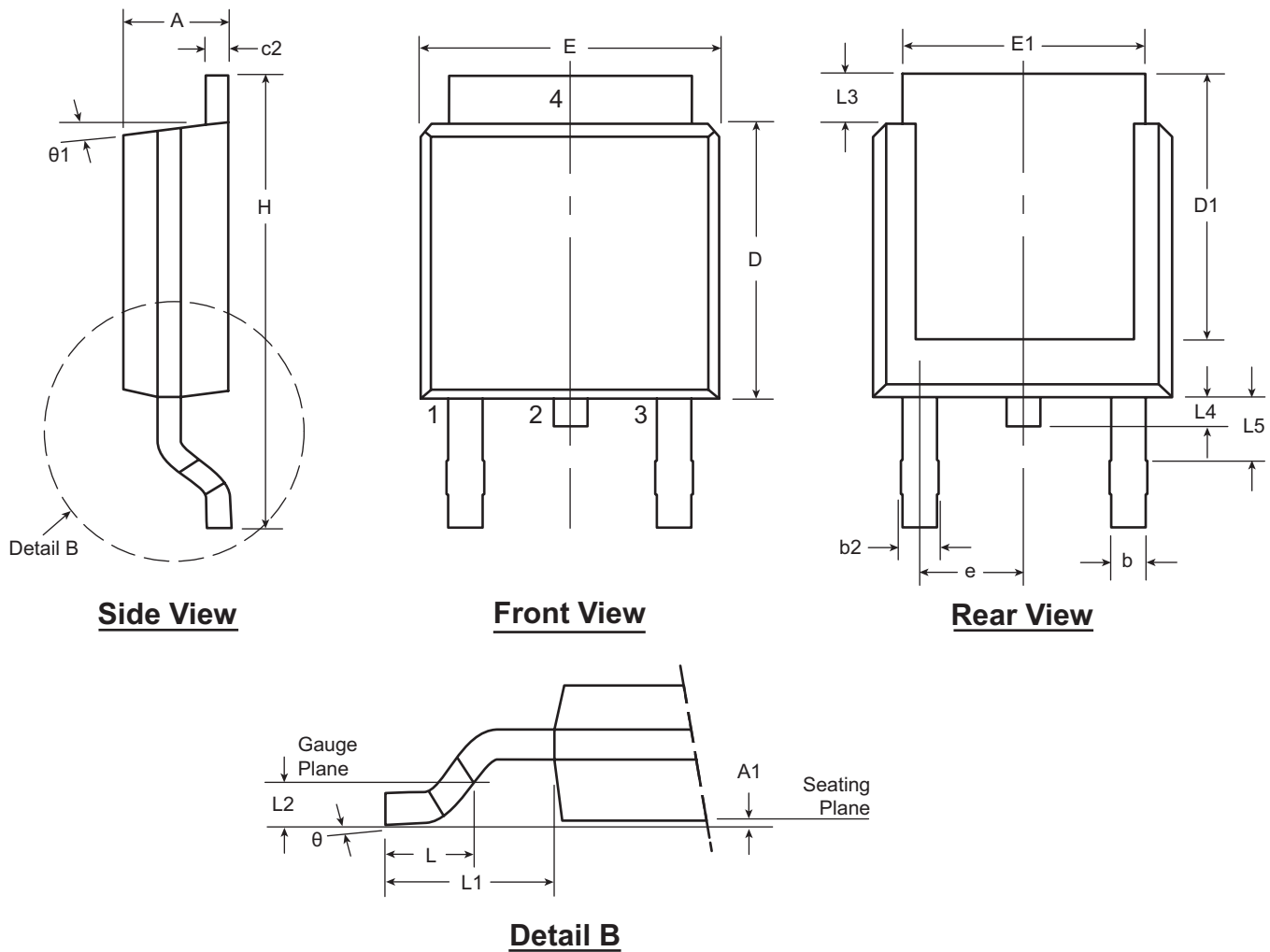

Notes:

1. 4 terminal locations are shown, only 3 are functional. Lead number 2 was removed.

Symbol	A	A1	b	b2	c2	D	D1	E	E1	e	H	L	L1	L2	L3	L4	L5	θ	θ_1			
Dimension (inches)	MIN	.086	-	.025	.030	.018	.235	.205	.250	.170	.090 BSC	.370	.055	.108 REF	.020 BSC	.035	-	.045	0°	0°		
	NOM	-	-	-	-	.240	-	-	-	-		-	.060			-	-	-	-	-	-	-
	MAX	.094	.005	.035	.045	.035	.245	-	.265	-		.410	.070			-	-	.050	.040	.060	10°	15°

JEDEC Registration TO-252, Variation AA, Issue E, June 2004.

Drawings not to scale.

Supertex inc. does not recommend the use of its products in life support applications, and will not knowingly sell its products for use in such applications, unless it receives an adequate "product liability indemnification insurance agreement". **Supertex** does not assume responsibility for use of devices described and limits its liability to the replacement of the devices determined defective due to workmanship. No responsibility is assumed for possible omissions or inaccuracies. Circuitry and specifications are subject to change without notice. For the latest product specifications, refer to the **Supertex** website: <http://www.supertex.com>.

3-Lead TO-92 Package (N3)

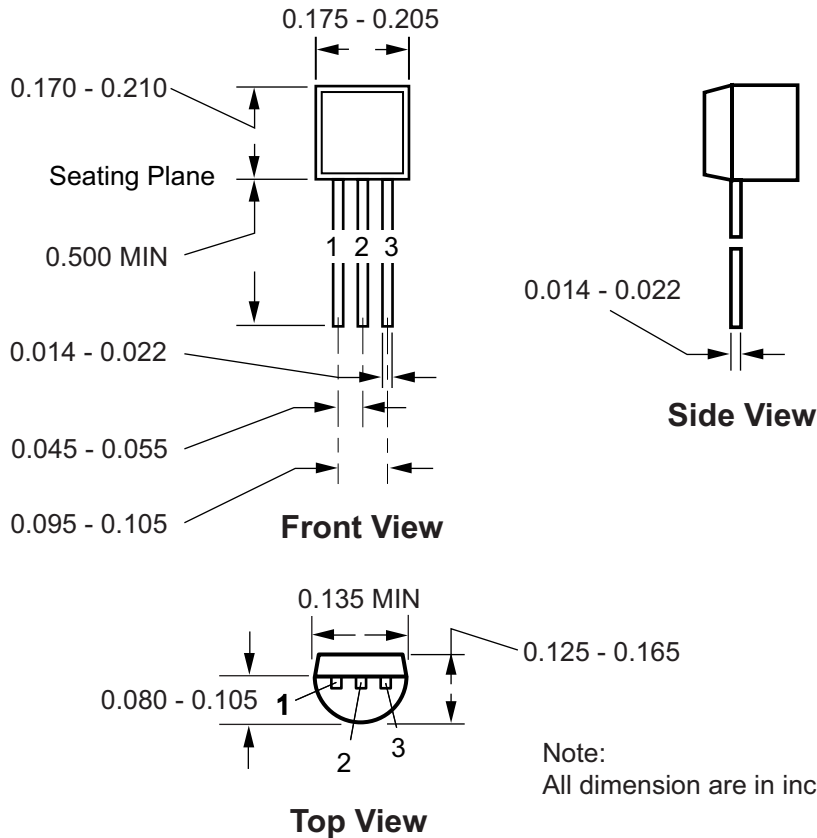

Note:
All dimension are in inches; angles are in degrees.

Supertex inc. does not recommend the use of its products in life support applications, and will not knowingly sell its products for use in such applications, unless it receives an adequate "product liability indemnification insurance agreement". **Supertex** does not assume responsibility for use of devices described and limits its liability to the replacement of the devices determined defective due to workmanship. No responsibility is assumed for possible omissions or inaccuracies. Circuitry and specifications are subject to change without notice. For the latest product specifications, refer to the **Supertex** website: <http://www.supertex.com>.

©2006 **Supertex inc.** All rights reserved. Unauthorized use or reproduction is prohibited.

3-Lead TO-243AA (SOT-89) Surface Mount Package (N8)

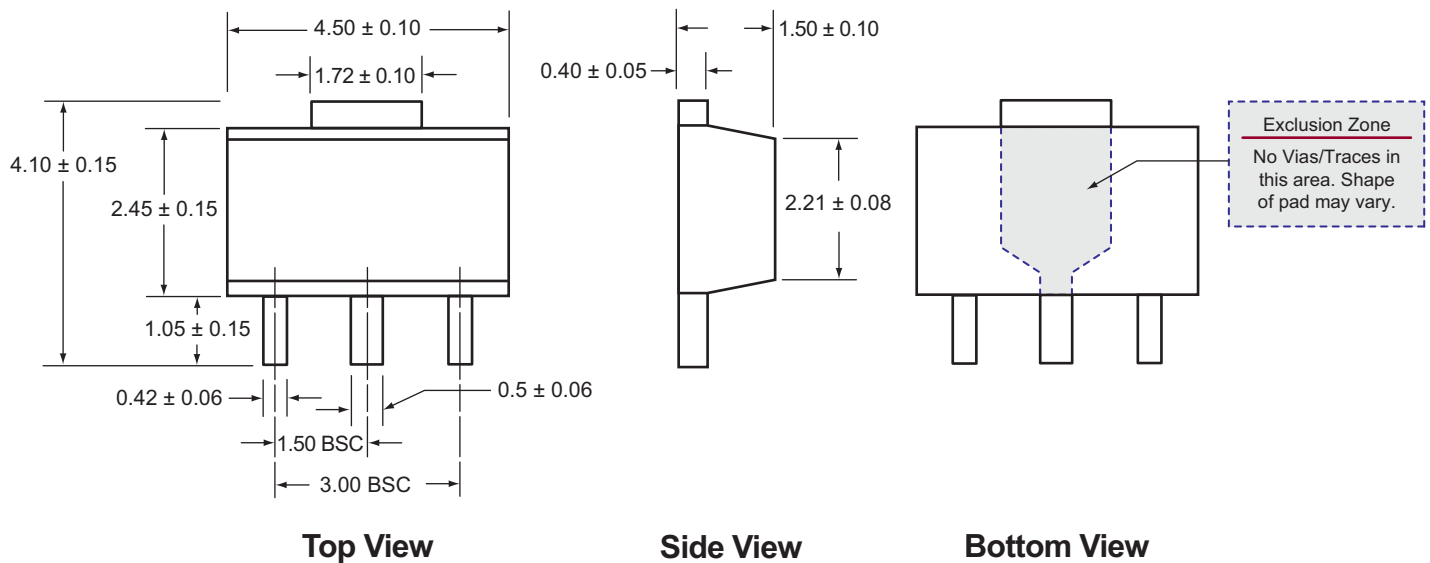

Notes:

1. All dimensions are in millimeters; all angles in degrees.

Supertex inc. does not recommend the use of its products in life support applications, and will not knowingly sell its products for use in such applications, unless it receives an adequate "product liability indemnification insurance agreement". **Supertex** does not assume responsibility for use of devices described and limits its liability to the replacement of the devices determined defective due to workmanship. No responsibility is assumed for possible omissions or inaccuracies. Circuitry and specifications are subject to change without notice. For the latest product specifications, refer to the **Supertex** website: <http://www.supertex.com>.

©2006 **Supertex inc.** All rights reserved. Unauthorized use or reproduction is prohibited.