

MOTOROLA SEMICONDUCTOR TECHNICAL DATA

PRODUCT PREVIEW DUAL TONE MULTIPLE FREQUENCY RECEIVER

The MC14LC5436 is a silicon gate CMOS LSI device containing the filter and decoder for detection of a pair of tones conforming to the DTMF standard with outputs in hexadecimal. Switched capacitor filter technology is used together with digital circuitry for the timing control and output circuits. The MC14LC5436 provides excellent power line noise, and dial tone rejection and is suitable for applications in central office equipment, PABX, and keyphone systems, remote control equipment and consumer telephony products.

The MC14LC5436 offers the following performance features:

- Single +5V Power Supply
- Detects all 16 Standard Digits
- Uses Inexpensive 3.58MHz Crystal
- Provides Guard Time Controls to Improve Speech Immunity
- Output in 4-bit Hexadecimal Code
- Built in 60Hz, and Dial Tone Rejection
- Pin Compatible With SSI-204

BLOCK DIAGRAM

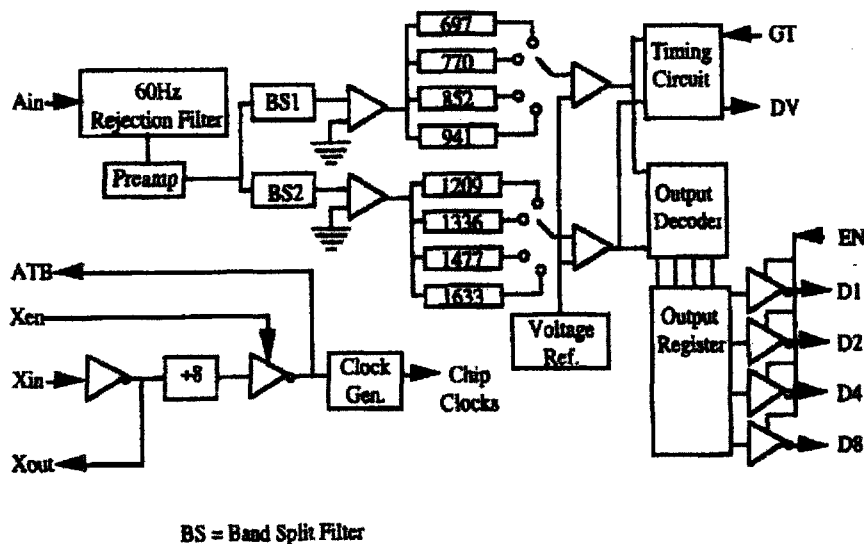

MC14LC5436

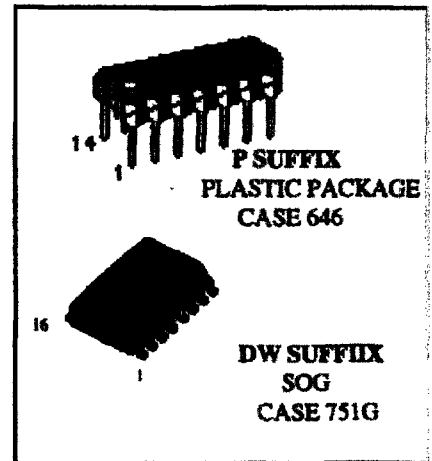

PIN ASSIGNMENT

DIP

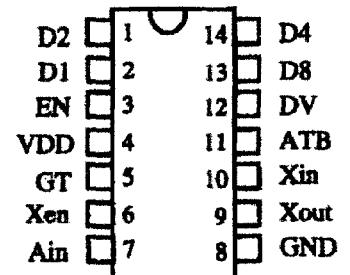

SOG

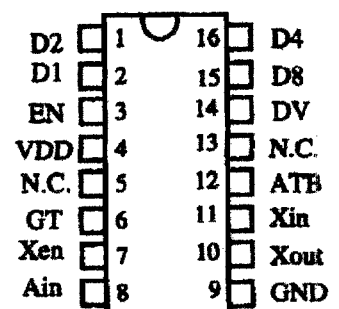

N.C. = NO CONNECTION



Absolute Maximum Ratings (Voltages referenced to GND, except where noted)

Rating	Symbol	Value	Unit
DC Supply Voltage	VDD	-0.5 to +6.0	V
Input Voltage, (Any Pin except Ain)	Vin	-0.5 to VDD +0.5	V
Input Voltage, Ain	Vin	VDD-10 to VDD+0.5	V
DC Current Drain per Pin	I	±10	mAdc
Power Dissipation	Pd	100	mW
Operating Temperature Range	Ta	-40 to +85	°C
Storage Temperature Range	Tstg	-65 to +150	°C

This device contains circuitry to protect the inputs against damage due to high static voltages or electrical fields; however, it is advised that normal precautions be taken to avoid applications of any voltage higher than the maximum rated voltages to this high impedance circuit. For proper operation it is recommended that Vin and Vout be constrained to the range $V_{SS} < (V_{in} \text{ or } V_{out}) < V_{DD}$. Reliability of operation is enhanced if unused inputs are tied to an appropriate logic voltage level (e.g., either V_{SS} or V_{DD}).

ELECTRICAL CHARACTERISTICS

(All polarities referenced to VSS=0V, VDD=5.0V±10% unless noted, -40°C to +85°C)

Parameter	Symbol	Min.	Typ.	Max.	Unit
DC Supply Voltage	VDD	4.5	5	5.5	V
Supply Current: CLK @ 3.58MHz	IDD	-	7	15	mA
Input Current GT pin	Iin	-	-	450±1	µA
Input Current EN, Xin, Xen					
Input Voltage Low (EN, GT, Xen)	Vil	-	-	1.5	V
Input Voltage High (EN, GT, Xen)	Vih	3.5	-	-	V
Iout Data & DV pins: Vout=4.5V(Source)	Ioh	800	-	-	µA
Iout Data & DV Pins: Vout=0.4V(Sink)	Iol	1.0			mA
Input Impedance : (Ain)	Rin	90	100	-	kΩ
ATB pin Fanout	Fout			10	
Input Capacitance: Xen & EN	Cin		6		pF

ANALOG CHARACTERISTICS

(VDD=5.0V±10%, -40°C to +85°C)

Parameter	Conditions	Min.	Typ.	Max.	Unit
Signal Level For Detection: (Ain)		-32		-2	dBm
Twist = High Tone/Low Tone		-10		10	dB
Frequency Detect Bandwidth		±(1.5+2Hz)	±2.5	±3.5	% fo
60hz Tolerance				0.8	Vrms
Dial Tone Tolerance note 1	Dial Tone 330+440			0	dB
Noise Tolerance note 1&2				-12	dB
Power Supply Noise	Wide Band			10	mVpp
Talk Off	Mitel tape #CM7290		2		hits

Notes

- (1) Referenced to lower amplitude tone
- (2) Bandwidth limited (0 to 3.4kHz) Gaussian Noise

AC CHARACTERISTICS (VDD=5.0V±10%, -40°C to +85°C)

CHARACTERISTIC	SYMBOL	Min	Typ	Max	Units
Tone On Time: For Detection	Ton	40			ms
Tone On Time: For Rejection				20	ms
Pause Time: For Detection	Toff	40			ms
Pause Time: For Rejection				20	ms
Detect Time: GT=0	Td	22		40	ms
Detect Time: GT=1		32		50	ms
Release Time GT=0	Tr	28		40	ms
Release Time GT=1		18		30	ms
Data Set Up Time	Tsu	7			µs
Data Hold Time	Th	4.2	4.6	5	ms
GT Width	Tgtw	18			µs
DV Reset Lag Time	Tdvr			5	ms
Enable High to Output Data Valid (note 3)	Tlz		120	500	ns
Enable low to Output High Z (note 3)	Thz		110	300	ns

Note 3 : Data Out : CL=35pf || RL=500

TIMING

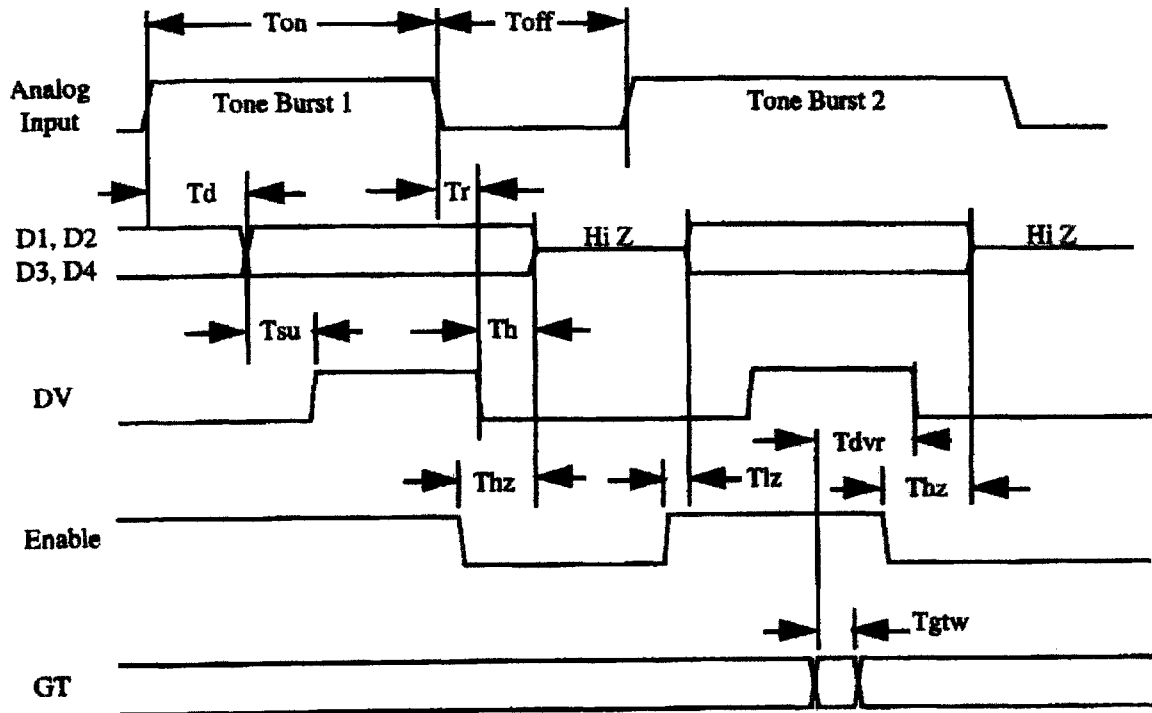

PIN DESCRIPTIONS

VDD- POSITIVE POWER SUPPLY

The digital supply pin, which is connected to the positive side of the power supply.

VSS- GROUND

Ground return pin is typically connected to the system ground.

D1, D2, D4, D8 DATA OUTPUT

These digital outputs provide the hexadecimal codes corresponding to the detected digit. The digital outputs become valid after a tone pair has been detected, and are cleared when a valid pause is timed. See table 1 for hexadecimal codes. These output pins are high impedance when the enable pin is at a logic "0".

EN- ENABLE

Outputs D1, D2, D4, D8 are enabled when EN is at a logic "1", and high impedance (disabled) when EN is at a logic "0".

GT- GUARD TIME

The Guard Time control input provides two sets of detected time, and release time, both within the allowed ranges of tone on and tone off. See Fig.2a. A longer tone detect time rejects signals too short to be considered valid. With $GT=1$, talk off performance is improved, since it reduces the probability that tones simulated by speech will maintain signal conditions long enough to be accepted. In addition, a shorter release time reduces the probability that a pause simulated by an interruption in speech will be detected as a valid pause. On the other hand, a shorter tone detect time with a long release time would be appropriate for an extremely noisy environment where fast acquisition time and immunity to dropouts would be required. In general, the tone signal time generated by a telephone is 100ms. nominal, followed by a pause of about 100ms. A high to low, or low to high transition on the GT pin resets the internal logic, and the MC14LC5436 is immediately ready to accept a new tone input.

XEN- OSCILLATOR ENABLE

A "1" on XEN enables the on chip crystal oscillator. When using alternate time base from the ATB pin, XEN should be tied to VSS.

AIN- ANALOG INPUT

This pin accepts the analog input, and is internally biased so that the input signal may be AC coupled. The input may be DC coupled so long as it does not exceed the positive supply. See Fig. 1

Xin / Xout- OSC IN AND OSC OUT

These pins connect to an internal crystal oscillator. In operation, a parallel resonant crystal is connected from Xin to Xout, as well as a $1M\Omega$ resistor in parallel with the crystal. When using the alternate clock source from ATB, Xin should be tied to VDD.

ATB- ALTERNATE TIME BASE

This pin serves as a frequency reference when more than one MC14LC5436 is used, such that only one crystal is required for multiple MC14LC5436s. When doing so, all ATB pins should be tied together as shown in Fig. 2b. When only one MC14LC5436 is used, this pin should be left unconnected. This pin output frequency is 447.4kHz.

DV- DATA VALID

DV signals a detection by going high after a valid tone pair is sensed and decoded at the output pins D1, D2, D4, D8. DV remains high until a loss of the current DTMF signal occurs, or until a transition in GT occurs.

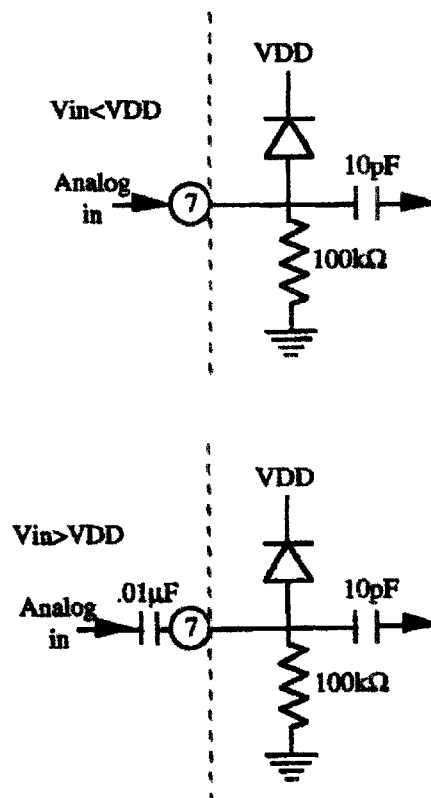

Fig. 1. Analog Input

(Operational Information based on PDIP package)

OPERATIONAL INFORMATION
(based on PDIP package)

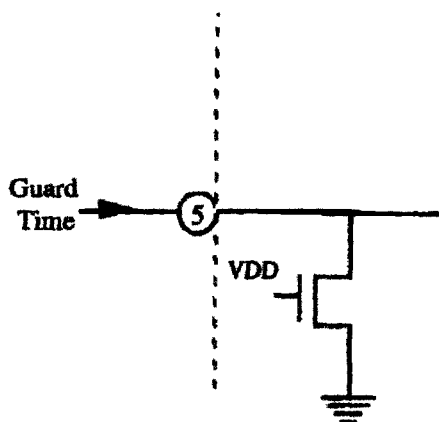

Fig. 2a

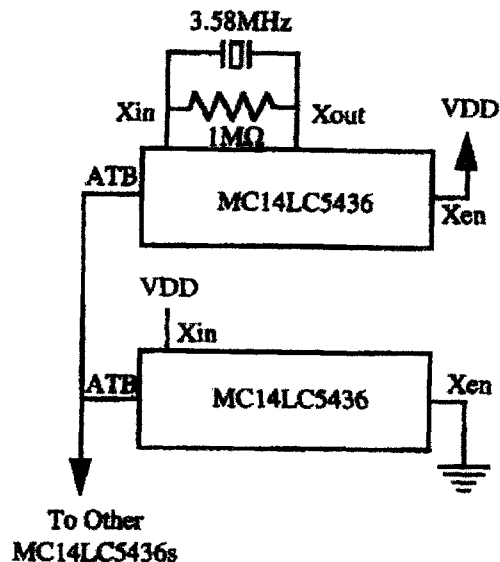

Fig. 2b

	COL.1	COL.2	COL.3	COL.4	
697	1	2	3	A	ROW 1
770	4	5	6	B	ROW 2
852	7	8	9	C	ROW 3
941	*	0	#	D	ROW 4
	1209	1336	1477	1633	

STD. DTMF HZ

4 x 4 KEYBOARD MATRIX

Fig. 3

Digit	Output Code			
	D8	D4	D2	D1
1	0	0	0	1
2	0	0	1	0
3	0	0	1	1
4	0	1	0	0
5	0	1	0	1
6	0	1	1	0
7	0	1	1	1
8	1	0	0	0
9	1	0	0	1
0	1	0	1	0
*	1	0	1	1
#	1	1	0	0
A	1	1	0	1
B	1	1	1	0
C	1	1	1	1
D	0	0	0	0

Table 1

Motorola reserves the right to make changes without notice to any products herein to improve reliability, function or design. Motorola does not assume any liability arising out of the application or use of any product or circuit described herein; neither does it convey any license under its patent rights nor the rights of others. Motorola and  are registered trademarks of Motorola, Inc. Motorola, Inc. is an equal Employment Opportunity/Affirmative Action Employer.