

To our customers,

---

## Old Company Name in Catalogs and Other Documents

---

On April 1<sup>st</sup>, 2010, NEC Electronics Corporation merged with Renesas Technology Corporation, and Renesas Electronics Corporation took over all the business of both companies. Therefore, although the old company name remains in this document, it is a valid Renesas Electronics document. We appreciate your understanding.

Renesas Electronics website: <http://www.renesas.com>

April 1<sup>st</sup>, 2010  
Renesas Electronics Corporation

Issued by: Renesas Electronics Corporation (<http://www.renesas.com>)

Send any inquiries to <http://www.renesas.com/inquiry>.

## Notice

1. All information included in this document is current as of the date this document is issued. Such information, however, is subject to change without any prior notice. Before purchasing or using any Renesas Electronics products listed herein, please confirm the latest product information with a Renesas Electronics sales office. Also, please pay regular and careful attention to additional and different information to be disclosed by Renesas Electronics such as that disclosed through our website.
2. Renesas Electronics does not assume any liability for infringement of patents, copyrights, or other intellectual property rights of third parties by or arising from the use of Renesas Electronics products or technical information described in this document. No license, express, implied or otherwise, is granted hereby under any patents, copyrights or other intellectual property rights of Renesas Electronics or others.
3. You should not alter, modify, copy, or otherwise misappropriate any Renesas Electronics product, whether in whole or in part.
4. Descriptions of circuits, software and other related information in this document are provided only to illustrate the operation of semiconductor products and application examples. You are fully responsible for the incorporation of these circuits, software, and information in the design of your equipment. Renesas Electronics assumes no responsibility for any losses incurred by you or third parties arising from the use of these circuits, software, or information.
5. When exporting the products or technology described in this document, you should comply with the applicable export control laws and regulations and follow the procedures required by such laws and regulations. You should not use Renesas Electronics products or the technology described in this document for any purpose relating to military applications or use by the military, including but not limited to the development of weapons of mass destruction. Renesas Electronics products and technology may not be used for or incorporated into any products or systems whose manufacture, use, or sale is prohibited under any applicable domestic or foreign laws or regulations.
6. Renesas Electronics has used reasonable care in preparing the information included in this document, but Renesas Electronics does not warrant that such information is error free. Renesas Electronics assumes no liability whatsoever for any damages incurred by you resulting from errors in or omissions from the information included herein.
7. Renesas Electronics products are classified according to the following three quality grades: “Standard”, “High Quality”, and “Specific”. The recommended applications for each Renesas Electronics product depends on the product’s quality grade, as indicated below. You must check the quality grade of each Renesas Electronics product before using it in a particular application. You may not use any Renesas Electronics product for any application categorized as “Specific” without the prior written consent of Renesas Electronics. Further, you may not use any Renesas Electronics product for any application for which it is not intended without the prior written consent of Renesas Electronics. Renesas Electronics shall not be in any way liable for any damages or losses incurred by you or third parties arising from the use of any Renesas Electronics product for an application categorized as “Specific” or for which the product is not intended where you have failed to obtain the prior written consent of Renesas Electronics. The quality grade of each Renesas Electronics product is “Standard” unless otherwise expressly specified in a Renesas Electronics data sheets or data books, etc.
  - “Standard”: Computers; office equipment; communications equipment; test and measurement equipment; audio and visual equipment; home electronic appliances; machine tools; personal electronic equipment; and industrial robots.
  - “High Quality”: Transportation equipment (automobiles, trains, ships, etc.); traffic control systems; anti-disaster systems; anti-crime systems; safety equipment; and medical equipment not specifically designed for life support.
  - “Specific”: Aircraft; aerospace equipment; submersible repeaters; nuclear reactor control systems; medical equipment or systems for life support (e.g. artificial life support devices or systems), surgical implantations, or healthcare intervention (e.g. excision, etc.), and any other applications or purposes that pose a direct threat to human life.
8. You should use the Renesas Electronics products described in this document within the range specified by Renesas Electronics, especially with respect to the maximum rating, operating supply voltage range, movement power voltage range, heat radiation characteristics, installation and other product characteristics. Renesas Electronics shall have no liability for malfunctions or damages arising out of the use of Renesas Electronics products beyond such specified ranges.
9. Although Renesas Electronics endeavors to improve the quality and reliability of its products, semiconductor products have specific characteristics such as the occurrence of failure at a certain rate and malfunctions under certain use conditions. Further, Renesas Electronics products are not subject to radiation resistance design. Please be sure to implement safety measures to guard them against the possibility of physical injury, and injury or damage caused by fire in the event of the failure of a Renesas Electronics product, such as safety design for hardware and software including but not limited to redundancy, fire control and malfunction prevention, appropriate treatment for aging degradation or any other appropriate measures. Because the evaluation of microcomputer software alone is very difficult, please evaluate the safety of the final products or system manufactured by you.
10. Please contact a Renesas Electronics sales office for details as to environmental matters such as the environmental compatibility of each Renesas Electronics product. Please use Renesas Electronics products in compliance with all applicable laws and regulations that regulate the inclusion or use of controlled substances, including without limitation, the EU RoHS Directive. Renesas Electronics assumes no liability for damages or losses occurring as a result of your noncompliance with applicable laws and regulations.
11. This document may not be reproduced or duplicated, in any form, in whole or in part, without prior written consent of Renesas Electronics.
12. Please contact a Renesas Electronics sales office if you have any questions regarding the information contained in this document or Renesas Electronics products, or if you have any other inquiries.

(Note 1) “Renesas Electronics” as used in this document means Renesas Electronics Corporation and also includes its majority-owned subsidiaries.

(Note 2) “Renesas Electronics product(s)” means any product developed or manufactured by or for Renesas Electronics.

# BIPOLAR ANALOG INTEGRATED CIRCUIT

## $\mu$ PC1678GV

### 5 V-BIAS, +17.5 dBm OUTPUT, 2.0 GHz WIDEBAND Si MMIC AMPLIFIER

#### ★ DESCRIPTION

The  $\mu$ PC1678GV is a silicon monolithic integrated circuit designed as medium output power amplifier for high frequency system applications. Due to +17.5 dBm TYP. output at 2 GHz, this IC is recommendable for transmitter stage amplifier of L BAND wireless communication systems.

The  $\mu$ PC1678GV has shrink package and compatible pin connections and supply voltage to  $\mu$ PC1678G. So, in the case of decreasing your system size,  $\mu$ PC1678GV is suitable to replace from  $\mu$ PC1678G.

This IC is manufactured using NEC's 20 GHz fr NESAT™IV silicon bipolar process. This process uses silicon nitride passivation film and gold electrodes. These materials can protect chip surface from external pollution and prevent corrosion/migration. Thus, this IC has excellent performance, uniformity and reliability.

#### FEATURES

- Supply voltage :  $V_{CC} = 4.5$  to  $5.5$  V
- Saturated output power :  $P_{O(sat)} = +17.5$  dBm TYP. @  $f = 500$  MHz with external inductor
- Wideband response :  $f_u = 2.0$  GHz TYP. @ 3 dB down below the gain at 0.1 GHz
- Power gain :  $G_P = 23$  dB TYP. @  $f = 500$  MHz
- Isolation :  $ISL = 35$  dB TYP. @  $f = 500$  MHz
- High-density surface mounting : 8-pin plastic SSOP package ( $3.0 \times 3.2 \times 1.8$  mm)

#### APPLICATIONS

- PA driver for high frequency system.

#### ORDERING INFORMATION

Part Number	Package	Marking	Supplying Form
$\mu$ PC1678GV-E1	8 pin plastic SSOP	1678	Embossed tape 8 mm wide. Pin 1 is in tape pull-out direction. Qty 1 kp/reel.

**Remark** To order evaluation samples, please contact your local NEC sales office.  
(Part number for sample order:  $\mu$ PC1678GV)

**Caution Electro-static sensitive devices**

The information in this document is subject to change without notice. Before using this document, please confirm that this is the latest version.  
Not all devices/types available in every country. Please check with local NEC representative for availability and additional information.

PIN CONNECTIONS

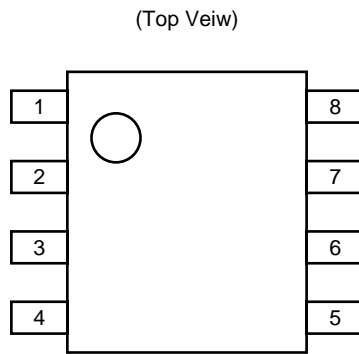

Pin No.	Pin Name
1	INPUT
2	GND
3	GND
4	GND
5	OUTPUT
6	GND
7	GND
8	V <sub>cc</sub>

PRODUCT LINE-UP (T<sub>A</sub> = +25 °C, V<sub>CC</sub> = V<sub>out</sub> = 5.0 V, Z<sub>s</sub> = Z<sub>L</sub> = 50 Ω)

Part Number	f <sub>u</sub> (GHz)	P <sub>O(sat)</sub> (dBm)	G <sub>P</sub> (dB)	NF (dB)	I <sub>cc</sub> (mA)	Package
μPC1678G	2.0	+17.5	23	6.0	49	8-pin plastic SOP
μPC1678GV	2.0	+17.5	23	6.0	49	8-pin plastic SSOP

**Remark** Typical performance. Please refer to ELECTRICAL CHARACTERISTICS in detail.

SYSTEM APPLICATION EXAMPLE

EXAMPLE OF PA driver in RF transmitter block

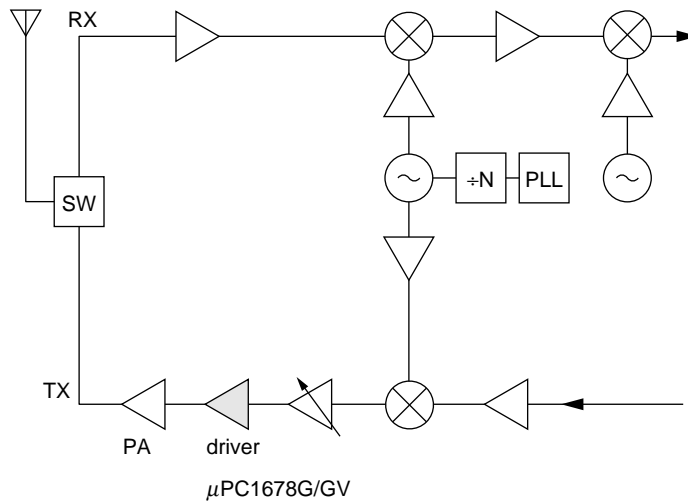

**PIN EXPLANATION**

Pin NO.	Pin Name	Applied Voltage (V)	Pin Voltage (V) <sup>Note</sup>	Functions and application	Internal equivalent circuit
1	INPUT	—	1.17	Signal input pin. A internal matching circuit, configured with resistors, enables 50 Ω connection over a wide band. A multi-feedback circuit is designed to cancel the deviations of h <sub>FE</sub> and resistance. This pin must be coupled to signal sause with capacitor for DC cut.	<p>2, 3, 4, 6 and 7 are shorted by a lead frame.</p>
5	OUTPUT	Voltage as same as V <sub>CC</sub> through external inductor	—	Signal output pin. This output is designed as open collector of derlington transistors. Connect an inductor between this pin and V <sub>CC</sub> pin to supply current to the internal output transistors. The inductor should be selected as high frequency use and small DC resistance.	
8	V <sub>CC</sub>	4.5 to 5.5	—	Power supply pin. This pin should be externally equipped with bypass capacitor to minimize ground impedance.	
6 7	GND	0	—	Ground pins of internal input stage. Form a ground pattern as wide as possible to minimize ground impedance.	
2 3 4	GND	0	—	Ground pins of internal output stage. All the ground pins including pin 6 and pin 7 must be connected together with wide ground pattern to decrease impedance difference.	

**Note** Pin voltage is measured at V<sub>CC</sub> = V<sub>out</sub> = 5.0 V.

**ABSOLUTE MAXIMUM RATINGS**

Parameter	Symbol	Conditions	Rating	Unit
Supply Voltage	V <sub>CC</sub>	T <sub>A</sub> = +25 °C, Pin 5 and 8	6	V
Input Power	P <sub>in</sub>	T <sub>A</sub> = +25 °C	+10	dBm
Power Dissipation	P <sub>D</sub>	Mounted on double sided copper clad 50 × 50 × 1.6 mm epoxy glass PWB (T <sub>A</sub> = +85 °C)	330	mW
Operating Ambient Temperature	T <sub>A</sub>		-45 to +85	°C
Storage Temperature	T <sub>stg</sub>		-55 to +150	°C

**RECOMMENDED OPERATING CONDITIONS**

Parameter	Symbol	MIN.	TYP.	MAX.	Unit	Notice
Supply Voltage	V <sub>CC</sub>	4.5	5.0	5.5	V	The same voltage should be applied to pin 5 and 8.
Operating Ambient Temperature	T <sub>A</sub>	-45	+25	+85	°C	

**ELECTRICAL CHARACTERISTICS (T<sub>A</sub> = + 25 °C, V<sub>CC</sub> = V<sub>out</sub> = 5.0 V, Z<sub>L</sub> = Z<sub>S</sub> = 50 Ω)**

Parameter	Symbol	Conditions	MIN.	TYP.	MAX.	Unit
Circuit Current	I <sub>CC</sub>	No signal	40	49	60	mA
Power Gain	G <sub>P</sub>	f = 500 MHz	21	23	25	dB
Noise Figure	NF	f = 500 MHz	—	6.0	8.0	dB
Upper Limit Operating Frequency	f <sub>u</sub>	3 dB down below from gain at f = 100 MHz	1.7	2.0	—	GHz
Isolation	ISL	f = 500 MHz	30	35	—	dB
Input Return Loss	RL <sub>in</sub>	f = 500 MHz	11	14	—	dB
Output Return Loss	RL <sub>out</sub>	f = 500 MHz	1	4	—	dB
Saturated Output Power Level	P <sub>O(sat)</sub>	f = 500 MHz	+15.5	+17.5	—	dBm

## TEST CIRCUIT

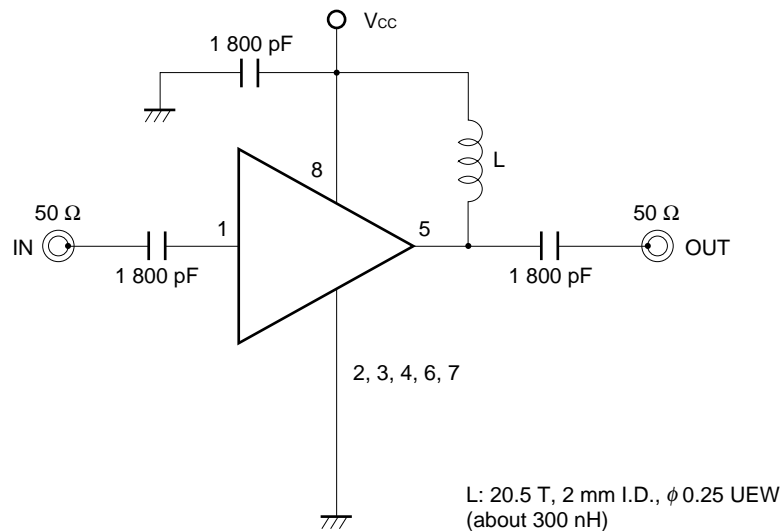
**INDUCTOR FOR THE OUTPUT PIN**

The internal output transistor of this IC consumes 30 mA, to output medium power. To supply current for output transistor, connect an inductor between the Vcc pin (pin 8) and output pin (pin 5).

The inductor has both DC and AC effects. In terms of DC, the inductor biases the output transistor with minimum voltage drop to output enable high level. In terms of AC, the inductor make output-port impedance higher to get enough gain. In this case, large inductance and Q is suitable.

**CAPACITORS FOR THE Vcc, INPUT AND OUTPUT PINS**

Capacitors of 1 800 pF are recommendable as the bypass capacitor for the Vcc pin and the coupling capacitors for the input and output pins.

The bypass capacitor connected to the Vcc pin is used to minimize ground impedance of Vcc pin. So, stable bias can be supplied against Vcc fluctuation.

The coupling capacitors, connected to the input and output pins, are used to cut the DC and minimize RF serial impedance. Their capacitance are therefore selected as lower impedance against a 50 Ω load. The capacitors thus perform as high pass filters, suppressing low frequencies to DC.

To obtain a flat gain from 100 MHz upwards, 1 800 pF capacitors are used in the test circuit. In the case of under 100 MHz operation, increase the value of coupling capacitor such as 10 000 pF. Because the coupling capacitors are determined by equation,  $C = 1/(2 \pi Rf_c)$ .

ILLUSTRATION OF THE TEST CIRCUIT ASSEMBLED ON EVALUATION BOARD

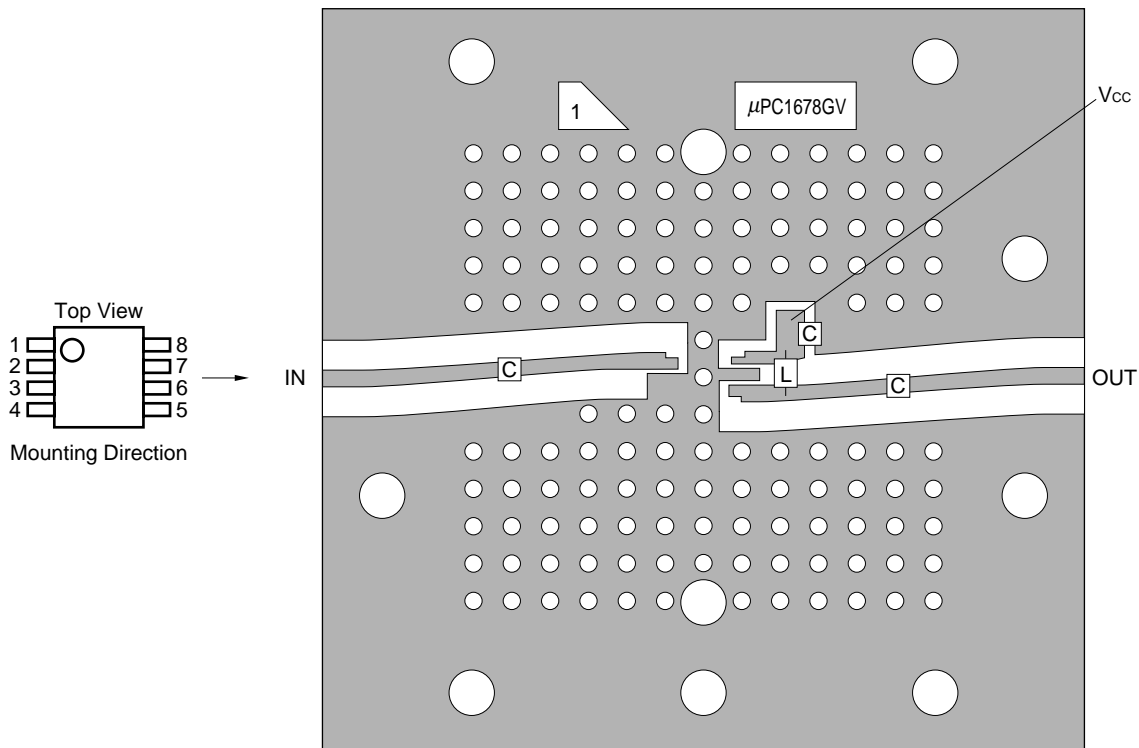

★ COMPONENT LIST

	Value
C	1 800 pF
L	300 nH

Notes

1. 50 × 50 × 0.4 mm double sided copper clad polyimide board.
2. Back side: GND pattern
3. Solder plated on pattern
4. ○ ○ : Through holes

For more information on the use of this IC, refer to the following application note: USAGE AND APPLICATION OF SILICON MEDIUM-POWER HIGH-FREQUENCY AMPLIFIER MMIC (P12152E).

★ TYPICAL CHARACTERISTICS (Unless otherwise specified,  $T_A = +25\text{ }^\circ\text{C}$ )

CIRCUIT CURRENT vs. SUPPLY VOLTAGE

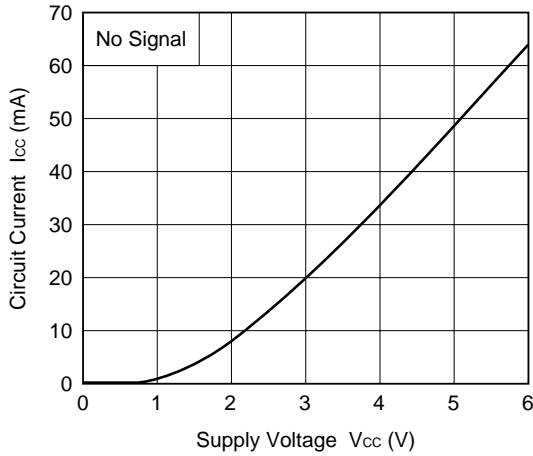

CIRCUIT CURRENT vs. OPERATING AMBIENT TEMPERATURE

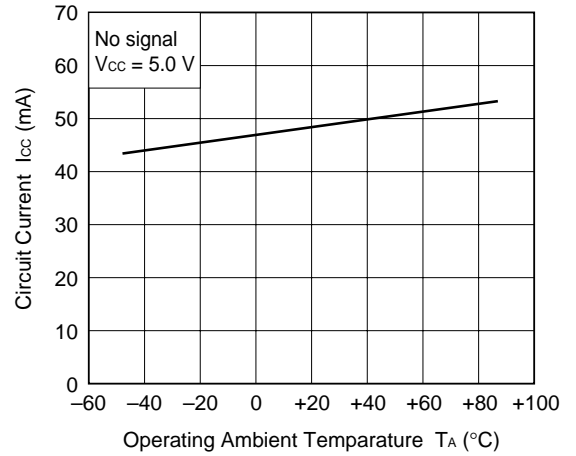

NOISE FIGURE, INSERTION POWER GAIN vs. FREQUENCY

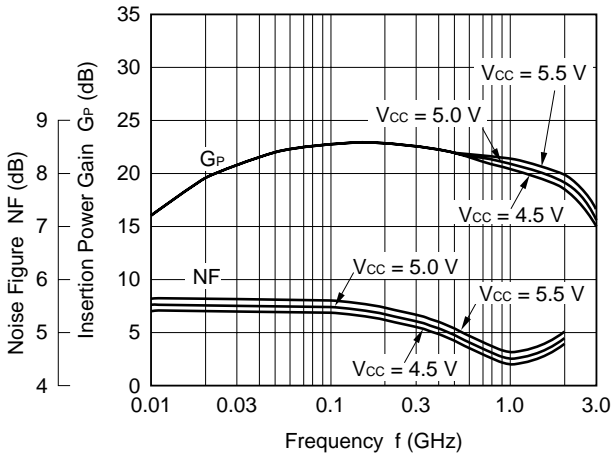

INSERTION POWER GAIN vs. FREQUENCY

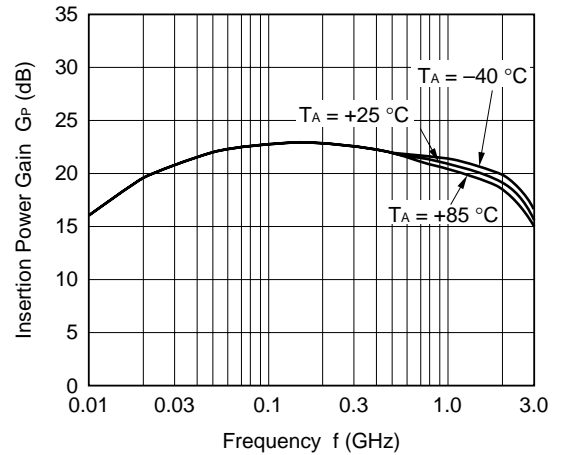

ISOLATION vs. FREQUENCY

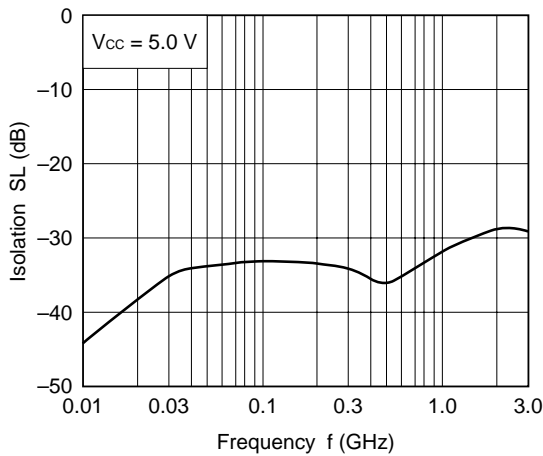

INPUT RETURN LOSS, OUTPUT RETURN LOSS vs. FREQUENCY

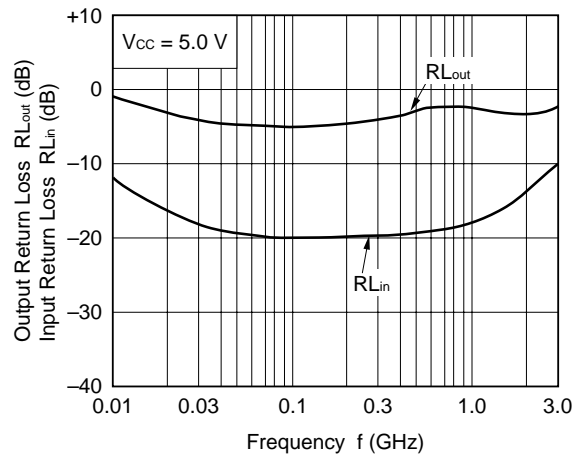

OUTPUT POWER vs. INPUT POWER

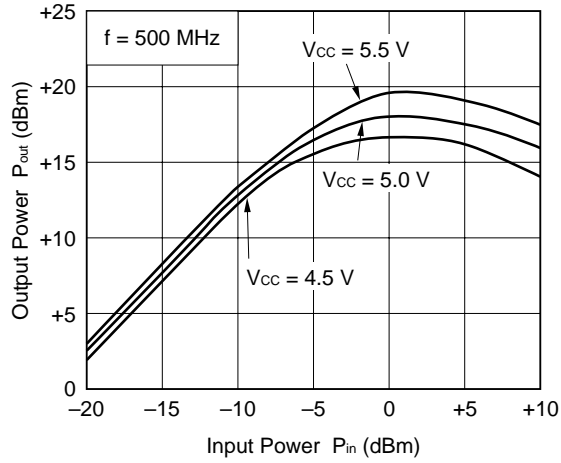

OUTPUT POWER vs. INPUT POWER

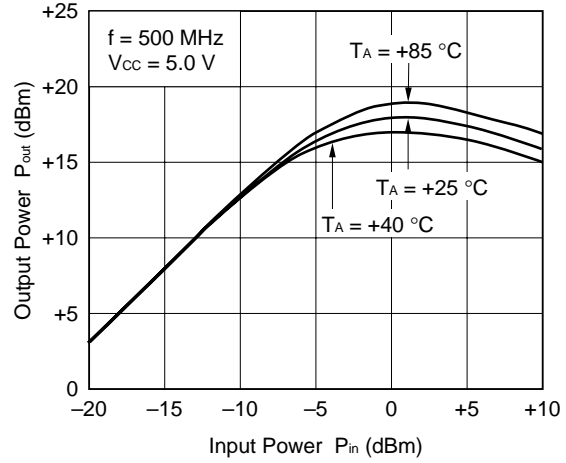

SATURATED OUTPUT POWER vs. FREQUENCY

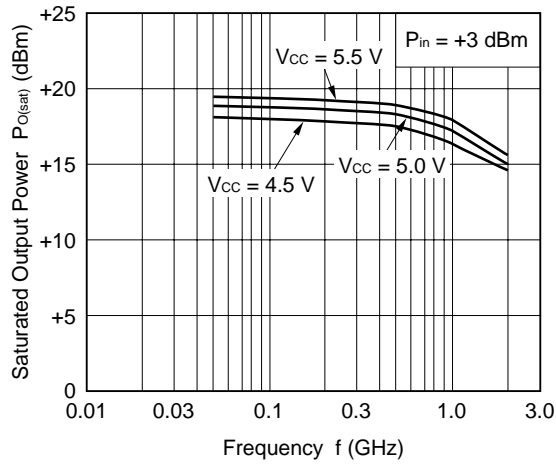

THIRD ORDER INTERMODULATION DISTORTION vs. OUTPUT POWER OF EACH TONE

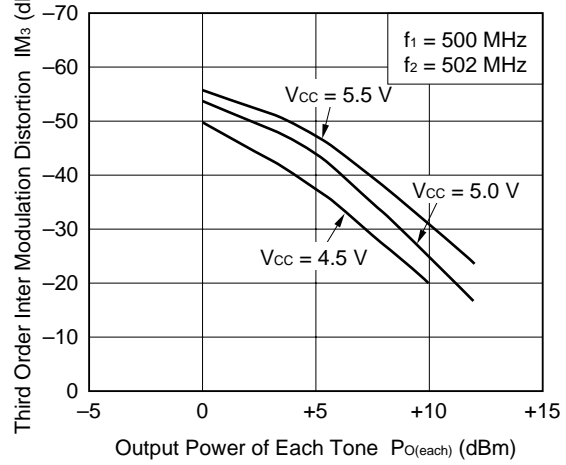

★ S-PARAMETER (TA = +25 °C, VCC = Vout = 5.0 V)

S11-FREQUENCY

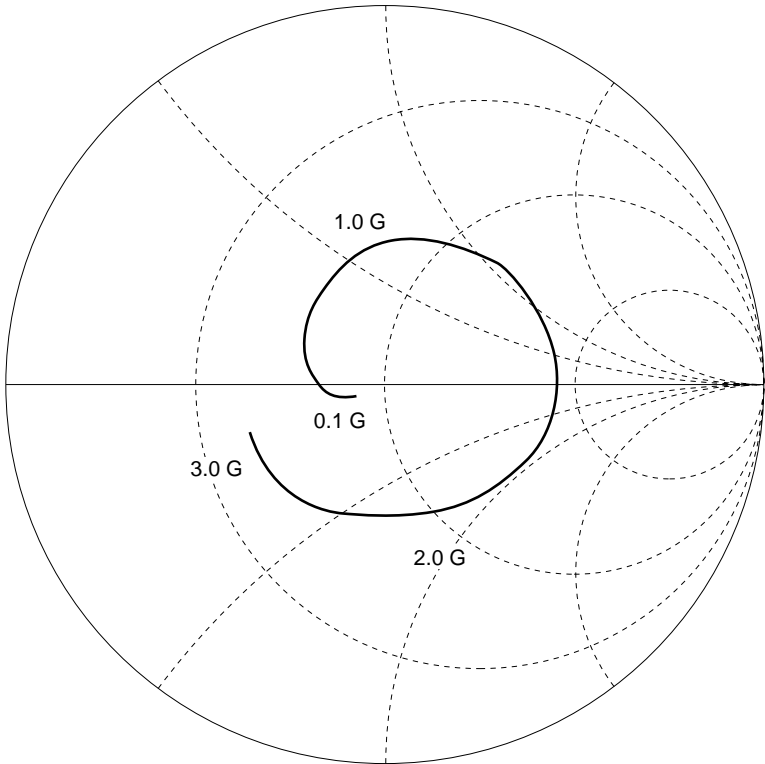

S22-FREQUENCY

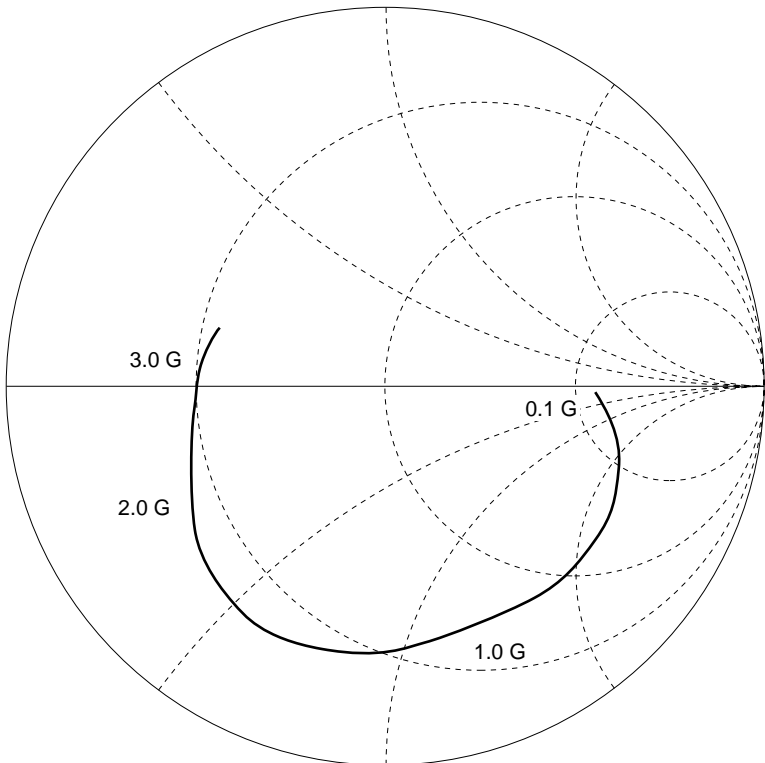

★ TYPICAL S-PARAMETER VALUES (T<sub>A</sub> = +25 °C)

V<sub>CC</sub> = V<sub>out</sub> = 5.0 V I<sub>CC</sub> = 44 mA

FREQUENCY MHz	S <sub>11</sub>		S <sub>21</sub>		S <sub>12</sub>		S <sub>22</sub>		K
	MAG.	ANG.	MAG.	ANG.	MAG.	ANG.	MAG.	ANG.	
100.0000	0.085	-163.8	12.206	-2.6	0.024	-5.0	0.558	-2.3	1.36
200.0000	0.118	-163.3	12.842	-6.0	0.020	-8.1	0.594	-6.6	1.43
300.0000	0.158	-170.9	13.766	-10.9	0.015	-2.4	0.637	-13.6	1.61
400.0000	0.184	176.0	14.731	-17.7	0.016	11.1	0.667	-21.3	1.39
500.0000	0.214	164.8	15.815	-25.1	0.014	26.3	0.692	-30.8	1.34
600.0000	0.243	152.4	16.598	-33.9	0.015	44.5	0.703	-40.2	1.13
700.0000	0.266	138.9	17.541	-43.2	0.019	51.4	0.701	-49.0	0.85
800.0000	0.293	125.2	18.057	-52.3	0.024	56.5	0.689	-57.0	0.69
900.0000	0.312	113.7	18.475	-62.2	0.027	58.1	0.670	-65.7	0.62
1000.0000	0.379	95.6	20.083	-71.9	0.031	61.7	0.686	-68.6	0.47
1100.0000	0.381	82.2	20.090	-82.8	0.035	58.6	0.685	-77.5	0.45
1200.0000	0.401	66.5	20.620	-94.0	0.038	56.0	0.688	-84.9	0.42
1300.0000	0.422	51.1	20.669	-106.8	0.042	55.1	0.702	-92.8	0.38
1400.0000	0.446	34.0	20.473	-119.6	0.046	52.6	0.713	-100.5	0.36
1500.0000	0.455	16.6	19.765	-132.5	0.048	48.4	0.717	-110.4	0.35
1600.0000	0.465	-0.5	18.759	-145.7	0.050	47.0	0.711	-119.0	0.36
1700.0000	0.444	-16.7	17.137	-157.7	0.049	44.9	0.684	-128.7	0.42
1800.0000	0.431	-33.5	15.512	-168.9	0.050	42.9	0.659	-137.4	0.48
1900.0000	0.397	-47.2	13.846	-178.7	0.048	43.5	0.616	-145.1	0.59
2000.0000	0.378	-59.2	12.398	172.4	0.048	45.8	0.574	-151.4	0.70
2100.0000	0.357	-70.5	11.060	164.9	0.048	45.3	0.540	-157.0	0.81
2200.0000	0.343	-80.7	9.918	157.8	0.048	47.4	0.510	-161.5	0.91
2300.0000	0.339	-89.4	8.927	151.7	0.049	47.4	0.489	-164.8	1.00
2400.0000	0.335	-98.9	8.107	146.2	0.051	46.1	0.483	-167.6	1.06
2500.0000	0.338	-107.2	7.388	140.6	0.050	46.2	0.475	-171.7	1.15
2600.0000	0.358	-115.5	6.772	135.4	0.055	46.8	0.475	-173.8	1.16
2700.0000	0.359	-125.3	6.267	131.0	0.051	48.1	0.463	-178.1	1.32
2800.0000	0.368	-133.9	5.807	125.4	0.054	49.4	0.482	179.5	1.33
2900.0000	0.372	-143.4	5.450	121.3	0.051	49.6	0.489	173.4	1.45
3000.0000	0.375	-152.7	5.018	116.0	0.050	53.6	0.475	166.3	1.62
3100.0000	0.372	-161.4	4.684	110.5	0.053	57.5	0.453	161.4	1.66

★ PACKAGE DIMENSIONS

8 PIN PLASTIC SSOP (UNIT : mm)

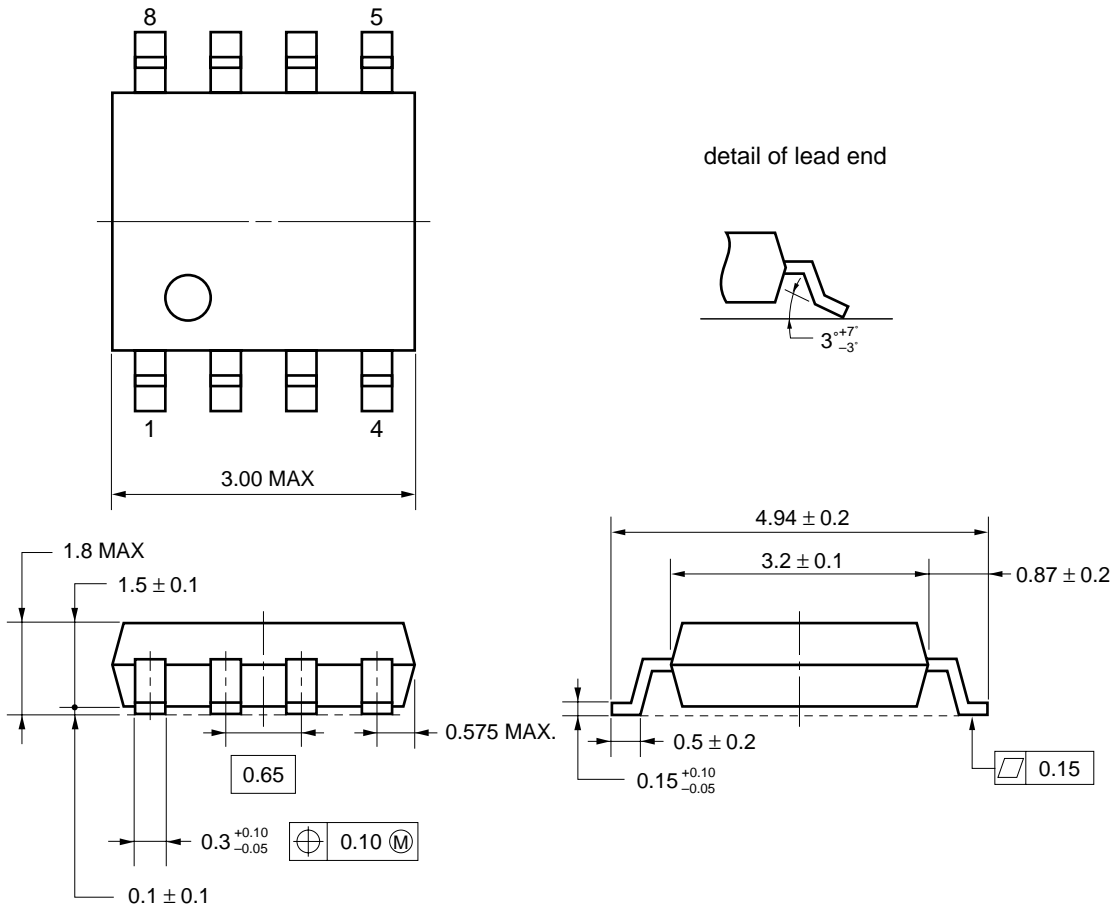

**NOTE** Each lead centerline is located within 0.10 mm of its true position (T.P.) at maximum material condition.

**NOTE ON CORRECT USE**

- (1) Observe precautions for handling because of electro-static sensitive devices.
- (2) Form a ground pattern as widely as possible to minimize ground impedance (to prevent undesired oscillation). All the ground pins must be connected together with wide ground pattern to decrease impedance difference.
- (3) The bypass capacitor should be attached to Vcc line.
- (4) The inductor must be attached between Vcc and output pins. The inductance value should be determined in accordance with desired frequency.
- (5) The DC cut capacitor must be each attached to the input and output pins.

**RECOMMENDED SOLDERING CONDITIONS**

This product should be soldered under the following recommended conditions. For soldering methods and conditions other than those recommended below, contact your NEC sales representative.

Soldering Method	Soldering Conditions	Recommended Condition Symbol
Infrared Reflow	Package peak temperature: 235 °C or below Time: 30 seconds or less (at 210 °C) Count: 3, Exposure limit <sup>Note</sup> : None	IR35-00-3
VPS	Package peak temperature: 215 °C or below Time: 40 seconds or less (at 200 °C) Count: 3, Exposure limit <sup>Note</sup> : None	VP15-00-3
Wave Soldering	Soldering bath temperature: 260 °C or below Time: 10 seconds or less Count: 1, Exposure limit <sup>Note</sup> : None	WS60-00-1
Partial Heating	Pin temperature: 300 °C Time: 3 seconds or less (per side of device) Exposure limit <sup>Note</sup> : None	—

**Note** After opening the dry pack, keep it in a place below 25 °C and 65 % RH for the allowable storage period.

**Caution** Do not use different soldering methods together (except for partial heating).

For details of recommended soldering conditions for surface mounting, refer to information document **SEMICONDUCTOR DEVICE MOUNTING TECHNOLOGY MANUAL (C10535E)**.

[MEMO]

[MEMO]

[MEMO]

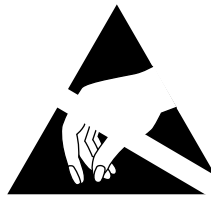

## ATTENTION

OBSERVE PRECAUTIONS  
FOR HANDLING  
ELECTROSTATIC  
SENSITIVE  
DEVICES

**NESAT (NEC Silicon Advanced Technology) is a trademark of NEC Corporation.**

- **The information in this document is subject to change without notice. Before using this document, please confirm that this is the latest version.**
  - No part of this document may be copied or reproduced in any form or by any means without the prior written consent of NEC Corporation. NEC Corporation assumes no responsibility for any errors which may appear in this document.
  - NEC Corporation does not assume any liability for infringement of patents, copyrights or other intellectual property rights of third parties by or arising from use of a device described herein or any other liability arising from use of such device. No license, either express, implied or otherwise, is granted under any patents, copyrights or other intellectual property rights of NEC Corporation or others.
  - Descriptions of circuits, software, and other related information in this document are provided for illustrative purposes in semiconductor product operation and application examples. The incorporation of these circuits, software, and information in the design of the customer's equipment shall be done under the full responsibility of the customer. NEC Corporation assumes no responsibility for any losses incurred by the customer or third parties arising from the use of these circuits, software, and information.
  - While NEC Corporation has been making continuous effort to enhance the reliability of its semiconductor devices, the possibility of defects cannot be eliminated entirely. To minimize risks of damage or injury to persons or property arising from a defect in an NEC semiconductor device, customers must incorporate sufficient safety measures in its design, such as redundancy, fire-containment, and anti-failure features.
  - NEC devices are classified into the following three quality grades:  
"Standard", "Special", and "Specific". The Specific quality grade applies only to devices developed based on a customer designated "quality assurance program" for a specific application. The recommended applications of a device depend on its quality grade, as indicated below. Customers must check the quality grade of each device before using it in a particular application.
    - Standard: Computers, office equipment, communications equipment, test and measurement equipment, audio and visual equipment, home electronic appliances, machine tools, personal electronic equipment and industrial robots
    - Special: Transportation equipment (automobiles, trains, ships, etc.), traffic control systems, anti-disaster systems, anti-crime systems, safety equipment and medical equipment (not specifically designed for life support)
    - Specific: Aircraft, aerospace equipment, submersible repeaters, nuclear reactor control systems, life support systems or medical equipment for life support, etc.
- The quality grade of NEC devices is "Standard" unless otherwise specified in NEC's Data Sheets or Data Books. If customers intend to use NEC devices for applications other than those specified for Standard quality grade, they should contact an NEC sales representative in advance.