

TC74HC4020AP/AF/AFN TC74HC4040AP/AF/AFN

TC74HC4020 14-Stage Binary Counter

TC74HC4040 12-Stage Binary Counter

The TC74HC4020A/TC74HC4040A are high speed CMOS BINARY COUNTER/DIVIDERS fabricated with silicon gate C²MOS technology.

They achieve the high speed operation similar to equivalent LSTTL while maintaining the CMOS low power dissipation.

The TC74HC4020 is a 14-STAGE BINARY COUNTER, and the TC74HC4040A is a 12-STAGE BINARY COUNTER.

Setting CLEAR to high resets the counter to low.

A negative transition on the CLOCK input brings one increment into the counter.

The TC74HC4020A provides 12 divided outputs: 1st state and stage 4 through stage 14. At Q14, as 1/16384 divided frequency will be output.

The TC74HC4040A provides all divided output stages, and at Q12, a 1/4096 divided frequency will be output.

All inputs are equipped with protection circuits against static discharge or transient excess voltage.

Features

- High Speed: $f_{MAX} = 60\text{MHz(Typ.)}$ at $V_{CC} = 5\text{V}$
- Low Power Dissipation: $I_{CC} = 4\mu\text{A(Max.)}$ at $T_a = 25^\circ\text{C}$
- High Noise Immunity: $V_{NIH} = V_{NIL} = 28\%V_{CC}(\text{Min.})$
- Output Drive Capability: 10 LSTTL Loads
- Symmetrical Output Impedance: $I_{OH} = I_{OL} = 4\text{mA}(\text{Min.})$
- Balanced Propagation Delays: $t_{PLH} = t_{PHL}$
- Wide Operating Voltage Range: $V_{CC}(\text{opr}) = 2\text{V} \sim 6\text{V}$
- Pin and Function Compatible with 4020B/4040B

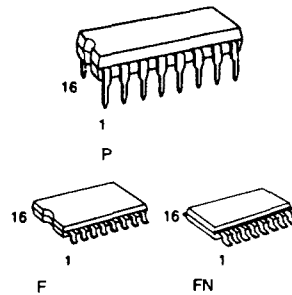

TC74HC4020A

TC74HC4040A

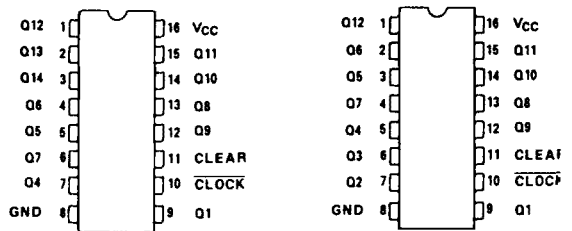

(TOP VIEW)

Pin Assignment

Truth Table

CLOCK	CLEAR	Output State
X	H	All Outputs = "L"
	L	No change
	L	Advance to Next State

X: Don't Care

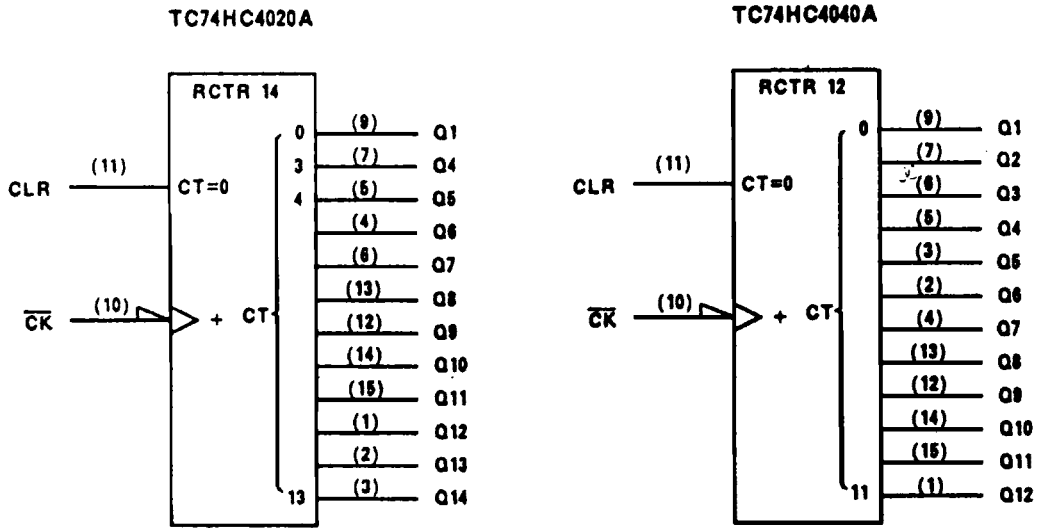

IEC Logic Symbol

TC74HC4020A

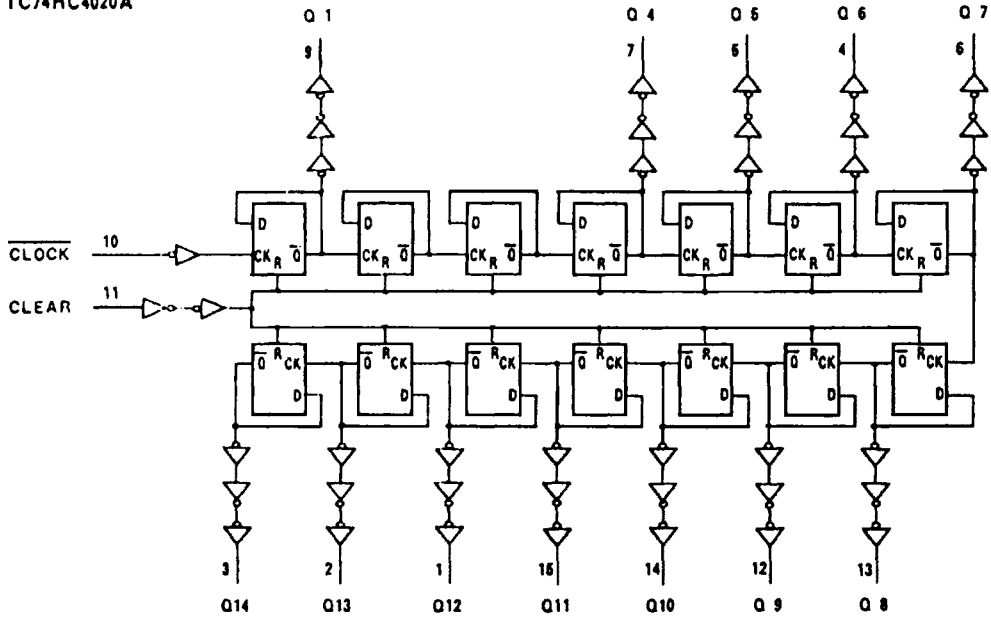

Logic Diagram

TC74HC4040A

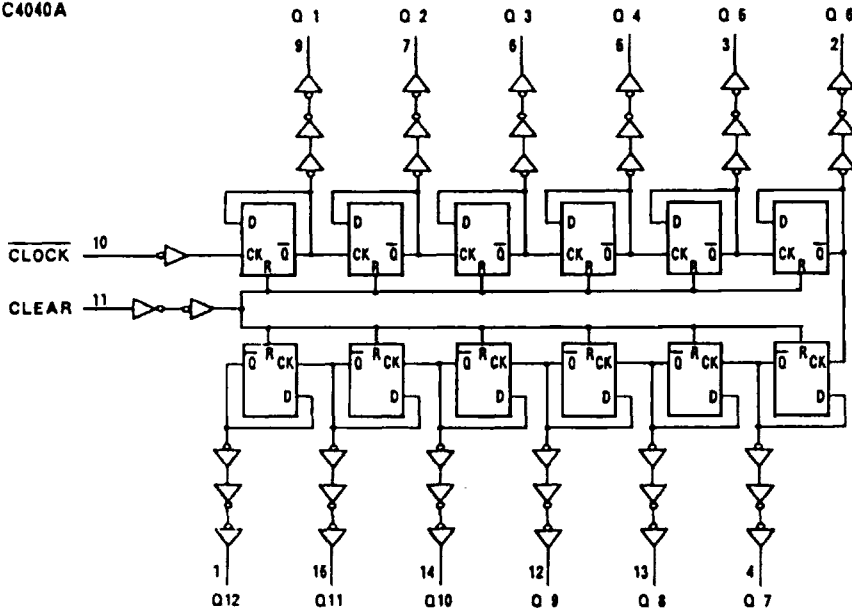

Timing Chart

Absolute Maximum Ratings

Parameter	Symbol	Value	Unit
Supply Voltage Range	V_{CC}	-0.5 - 7	V
DC Input Voltage	V_{IN}	-0.5 - $V_{CC} + 0.5$	V
DC Output Voltage	V_{OUT}	-0.5 - $V_{CC} + 0.5$	V
Input Diode Current	I_{IK}	±20	mA
Output Diode Current	I_{OK}	±20	mA
DC Output Current	I_{OUT}	±25	mA
DC V_{CC} /Ground Current	I_{CC}	±50	mA
Power Dissipation	P_D	500(DIP)*	mW
Storage Temperature	T_{stg}	-65 - 150	°C
Lead Temperature 10sec	T_L	300	°C

*500mW in the range of $T_a = -40^{\circ}\text{C} \sim 65^{\circ}\text{C}$. From $T_a = 65^{\circ}\text{C}$ to 85°C a derating factor of -10mW/°C shall be applied until 300mW.

Recommended Operating Conditions

Parameter	Symbol	Value	Unit
Supply Voltage	V_{CC}	2 - 6	V
Input Voltage	V_{IN}	0 - V_{CC}	V
Output Voltage	V_{OUT}	0 - V_{CC}	V
Operating Temperature	T_{opr}	-40 - 85	°C
Input Rise and Fall Time	t_r, t_f	0 - 1000($V_{CC} = 2.0\text{V}$) 0 - 500($V_{CC} = 4.5\text{V}$) 0 - 400($V_{CC} = 6.0\text{V}$)	ns

DC Electrical Characteristics

Parameter	Symbol	Test Condition	$T_a = 25^{\circ}\text{C}$			$T_a = -40 \sim 85^{\circ}\text{C}$		Unit		
			V_{CC}	Min.	Typ.	Max.	Min.		Max.	
High-Level Input Voltage	V_{IH}	-	2.0	1.5	-	-	1.5	-	V	
			4.5	3.15	-	-	3.15	-		
			6.0	4.2	-	-	4.2	-		
Low-Level Input Voltage	V_{IL}	-	2.0	-	-	0.5	-	0.5	V	
			4.5	-	-	1.35	-	1.35		
			6.0	-	-	1.8	-	1.8		
High-Level Output Voltage	V_{OH}	$V_{IN} = V_{IH}$ or V_{IL}	$I_{OH} = -20\mu\text{A}$	2.0	1.9	2.0	-	1.9	-	V
				4.5	4.4	4.5	-	4.4	-	
			$I_{OH} = -4\text{mA}$ $I_{OH} = -5.2\text{mA}$	4.5	4.18	4.31	-	4.13	-	
				6.0	5.68	5.80	-	5.63	-	
Low-Level Output Voltage	V_{OL}	$V_{IN} = V_{IH}$ or V_{IL}	$I_{OL} = 20\mu\text{A}$	2.0	-	0.0	0.1	-	0.1	V
				4.5	-	0.0	0.1	-	0.1	
			$I_{OL} = 4\text{mA}$ $I_{OL} = 5.2\text{mA}$	4.5	-	0.17	0.26	-	0.33	
				6.0	-	0.18	0.26	-	0.33	
Input Leakage Current	I_{IN}	$V_{IN} = V_{CC}$ or GND	6.0	-	-	±0.1	-	±1.0	μA	
Quiescent Supply Current	I_{CC}	$V_{IN} = V_{CC}$ or GND	6.0	-	-	4.0	-	40.0		

Timing Requirements (Input $t_r = t_f = 6\text{ns}$)

Parameter	Symbol	Test Condition	Ta = 25°C			Ta = -40-85°C		Unit
			V _{CC}	Typ.	Limit	Limit		
Minimum Pulse Width (CLOCK)	$t_{W(L)}$	-	2.0	-	75	95		ns
			4.5	-	15	19		
			6.0	-	13	16		
Minimum Pulse Width (CLEAR)	$t_{W(F)}$	-	2.0	-	75	95		
			4.5	-	15	19		
			6.0	-	13	16		
Minimum Removal Time	t_{rem}	-	2.0	-	25	30		
			4.5	-	5	6		
			6.0	-	5	5		
Clock Frequency	f	-	2.0	-	6	5		MHz
			4.5	-	30	24		
			6.0	-	35	28		

AC Electrical Characteristics (C_L = 15pF, V_{CC} = 5V, Ta = 25°C)

Parameter	Symbol	Test Condition	Min.	Typ.	Max.	Unit
Output Transition Time	t_{TLH} t_{THL}	-	-	4	8	ns
Propagation Delay Time (CLOCK-Q,1)	t_{PLH} t_{PHL}	-	-	16	24	
Propagation Delay Time (Qn-Qn+1)	t_{PLH} t_{PHL}	-	-	5	14	
Propagation Delay Time (CLEAR)	t_{PLH} t_{PHL}	-	-	14	24	
Maximum Clock Frequency	f_{MAX}	-	33	73	-	MHz

AC Electrical Characteristics (C_L = 50pF, Input $t_r = t_f = 6\text{ns}$)

Parameter	Symbol	Test Condition	Ta = 25°C			Ta = -40 ~ 85°C		Unit	
			V _{CC}	Min	Typ.	Max.	Min.		Max.
Output Transition Time	t_{TLH} t_{THL}	-	2.0	-	30	75	-	95	ns
			4.5	-	8	15	-	19	
			6.0	-	7	13	-	16	
Propagation Delay Time (CLOCK-Q,1)	t_{PLH} t_{PHL}	-	2.0	-	70	145	-	180	
			4.5	-	20	29	-	36	
			6.0	-	17	25	-	31	
Propagation Delay Time (Qn - Qn + 1)	t_{PLH} t_{PHL}	-	2.0	-	20	75	-	95	
			4.5	-	6	15	-	19	
			6.0	-	4	13	-	16	
Propagation Delay Time (CLEAR)	t_{PLH} t_{PHL}	-	2.0	-	55	140	-	175	
			4.5	-	17	28	-	35	
			6.0	-	14	24	-	30	
Maximum Clock Frequency	f_{MAX}	-	2.0	6	17	-	5	-	MHz
			4.5	30	66	-	24	-	
			6.0	35	78	-	28	-	
Input Capacitance	C _{IN}	-	-	5	10	-	10	pF	
Power Dissipation Capacitance	C _{PD(1)}	TC74HC4020A	-	27	-	-	-		
		TC74HC4040A	-	37	-	-	-		

Note (1) C_{PD} is defined as the value of the internal equivalent capacitance which is calculated from the operating current consumption without load. Average operating current can be obtained by the equation:

$$I_{CC(OP)} = C_{PD} \cdot V_{CC} \cdot f_{IN} + I_{CC}$$

Notes