

# MMA710X

## DC to 3 GHz Amplifier

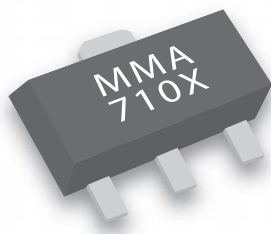

SOT89 OUTLINE



### Description:

The MMA710X is a fully matched amplifier fabricated in Aeroflex / Metelics reliable InGaP HBT technology. The economical SOT89 package provides excellent wide-band performance.

### Features:

- DC - 3 GHz Broadband Gain Block
- $\pm 0.5$  dB Typical Gain Flatness
- 50 Ohms Input/Output Impedances

### RF Specifications:

Parameter	Term	Minimum	Typical	Maximum	Units
3dB Bandwidth	BW	DC	---	3	GHz
Frequency Range	$f_o$	DC	---	3	GHz
Gain	$G_p$	11	12	---	dB
Output Power	$P_{1dB}$	+16	+18	---	dBm
Input Standing Wave Ratio	VSWR	---	1.5:1	2.0:1	---
Output Standing Wave Ratio	VSWR	---	2.0:1	2.5:1	---
3 <sup>rd</sup> Order Intercept Point	IP3	+30	+34	---	dBm
Noise Figure	NF	---	5.0	6.0	dB
Device Current	$I_c$	85	95	110	mA

- NOTES:
1.  $T_A = +25$  °C.
  2.  $V_S = 8.0$  Vdc,  $R_{BIAS} = 11$   $\Omega$
  3. IP3 measured with two tones offset 10 MHz at 0 dBm per tone.

### Absolute Maximum Ratings:

Parameters	Rating
Device Current ( $I_c$ )	150 mA
RF Input Power, continuous	+13 dBm
Operating Temperature	-40 to +85 °C
Storage Temperature	-55 to +125 °C
Thermal Resistance ( $\theta_{JC}$ )	70 °C/W



## Typical RF Performance:

Figure 1.

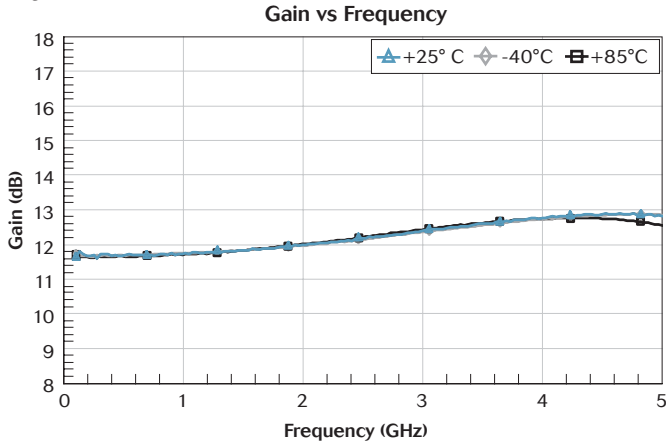

Figure 2.

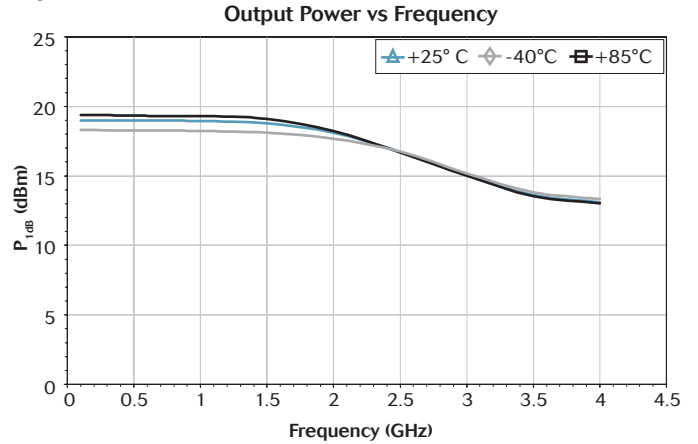

Figure 3.

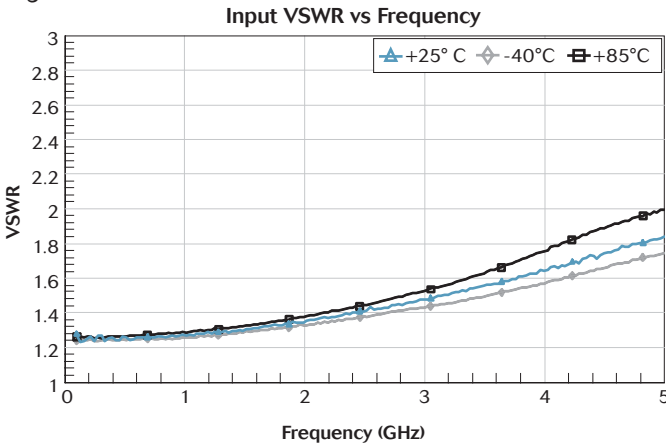

Figure 4.

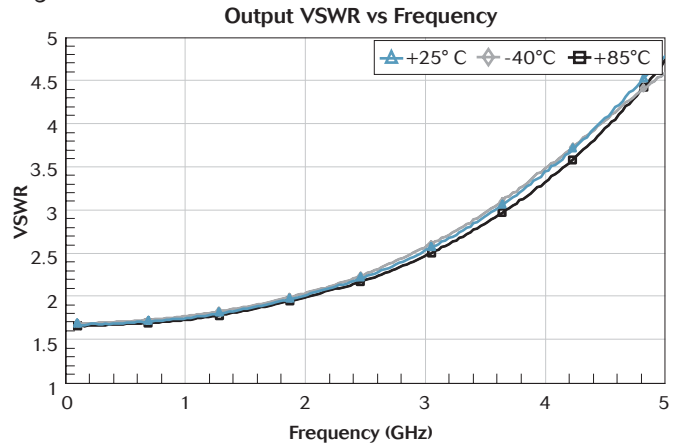

Figure 5.

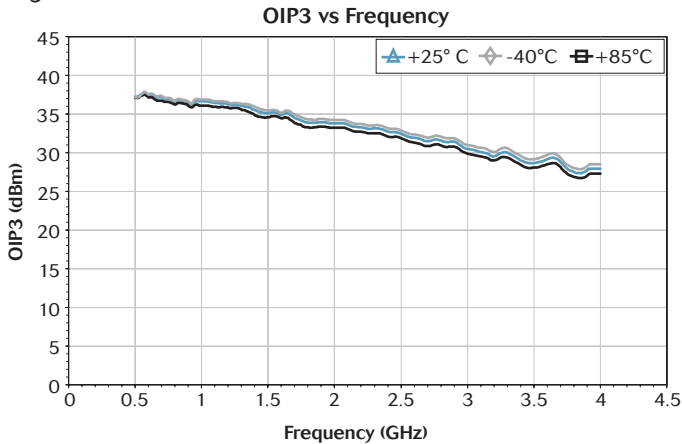
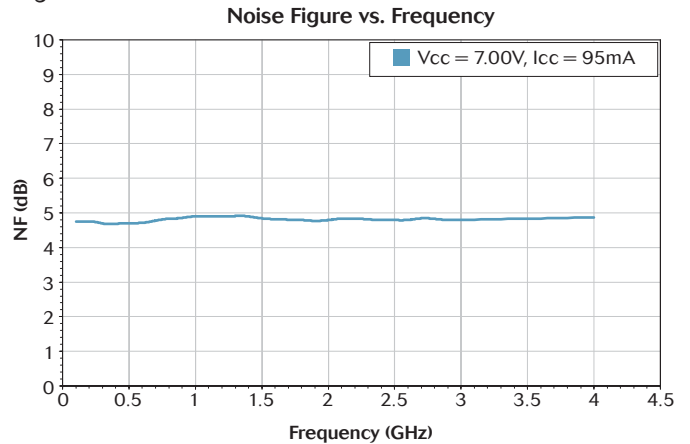

Figure 6.



# MMA710X DC to 3 GHz Amplifier



## SOT89 Outline Dimensions:

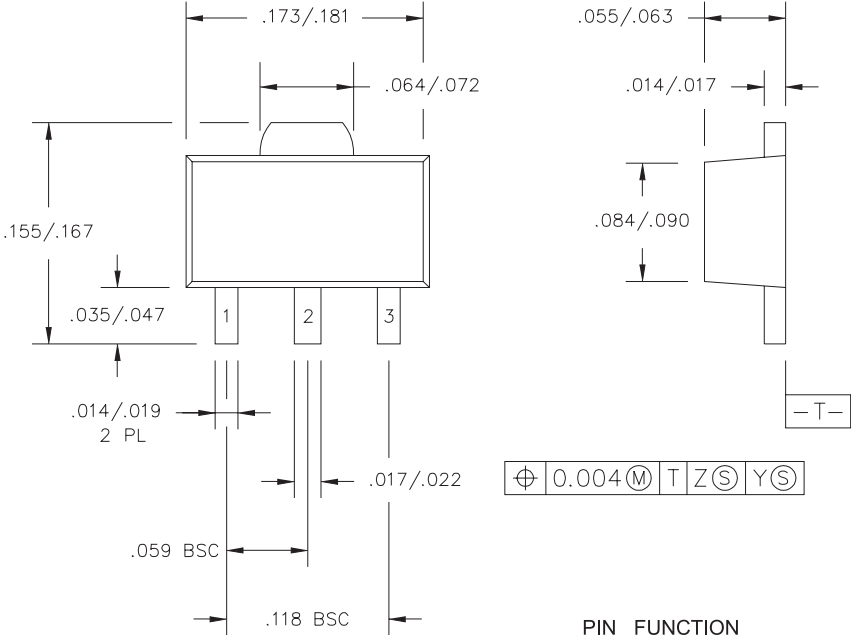

**PIN FUNCTION**

- 1 INPUT
- 2 GROUND
- 3 OUTPUT

ALL DIMENSIONS  $\pm 0.003$  INCH  
0.07 MM

## Recommended PCB Layout:

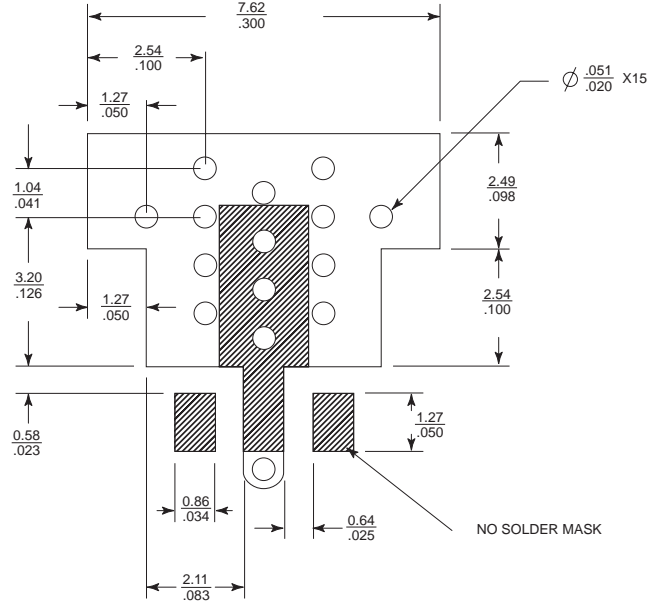

ALL DIMENSIONS  $\pm 0.001$  INCH  
0.02 MM

### Application Circuit:

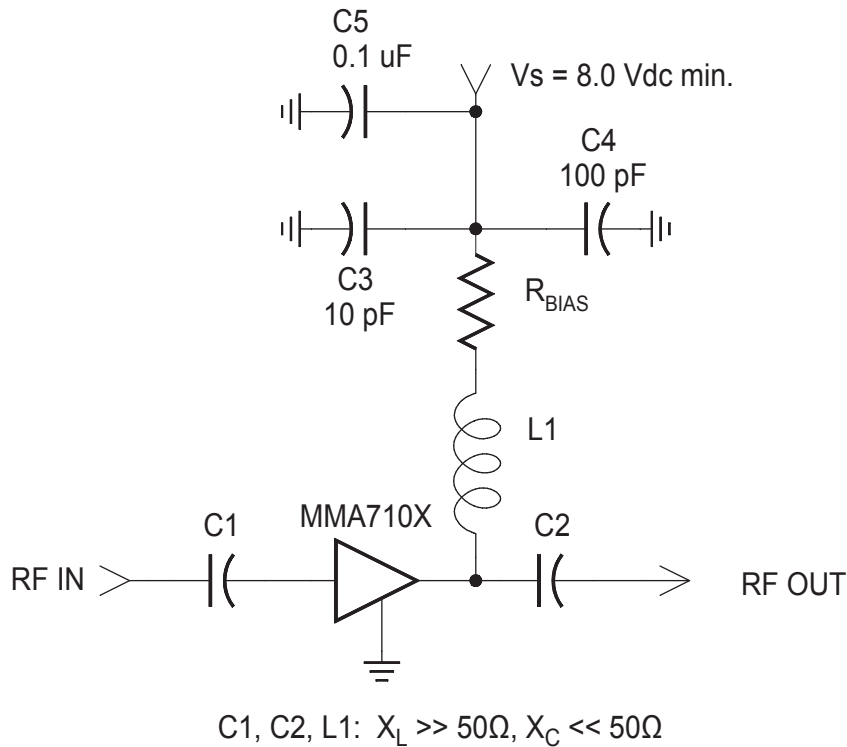

$R_{BIAS}$  vs.  $V_S$

$V_S$ (V)	8.0	10.0	12.0	15.0
$R_{BIAS}$ ( $\Omega$ )	11	30	51	86
Power Dissipation (W)	0.1	0.3	0.5	0.8

#### Aeroflex / Metelics Inc.

Aeroflex Microelectronic Solutions  
 975 Stewart Drive, Sunnyvale, CA 94085  
 TEL: 408-737-8181  
 Fax: 408-733-7645

[www.aeroflex-metelics.com](http://www.aeroflex-metelics.com)

[sales@eroflex-metelics.com](mailto:sales@eroflex-metelics.com)



Aeroflex / Metelics, Inc. reserves the right to make changes to any products and services herein at any time without notice. Consult Aeroflex or an authorized sales representative to verify that the information in this data sheet is current before using this product. Aeroflex does not assume any responsibility or liability arising out of the application or use of any product or service described herein, except as expressly agreed to in writing by Aeroflex; nor does the purchase, lease, or use of a product or service from Aeroflex convey a license under any patent rights, copyrights, trademark rights, or any other of the intellectual rights of Aeroflex or of third parties.

Copyright 2003 Aeroflex / Metelics. All rights reserved.



Our passion for performance is defined by three attributes represented by these three icons: solution-minded, performance-driven and customer-focused.