

1 000 to 1 600 nm OPTICAL FIBER COMMUNICATIONS φ30 μm InGaAs AVALANCHE PHOTO DIODE

DESCRIPTION

NDL5530 is an InGaAs avalanche photo diode especially designed for a detector of long wavelength optical fiber communications systems. It covers the wavelength range between 1 000 and 1 600 nm with high efficiency.

FEATURES

- Small dark current $I_D = 5 \text{ nA}$
- High quantum efficiency $\eta = 90 \% @ \lambda = 1\ 300 \text{ nm}, M = 1$
 $\eta = 77 \% @ \lambda = 1\ 550 \text{ nm}, M = 1$
- Cut-off frequency $f_c = 2.5 \text{ GHz MIN. @ } M = 10$
- Detecting area size $\phi 30 \mu\text{m}$

PACKAGE DIMENSIONS in millimeters

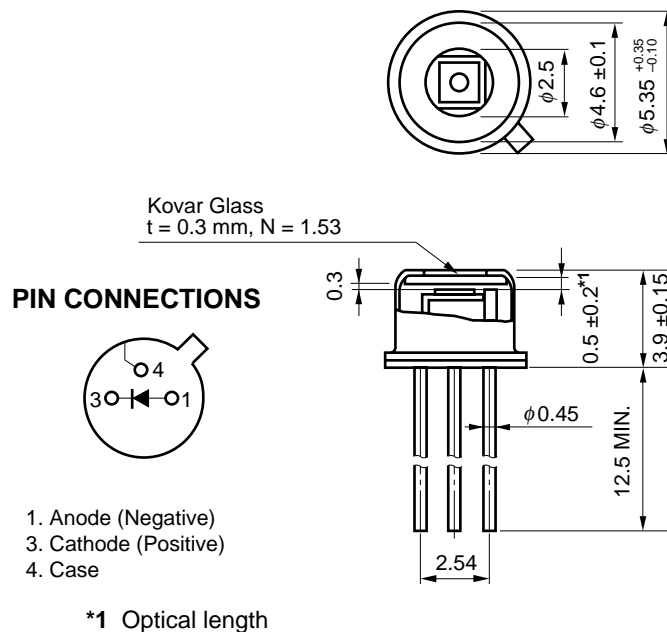

The information in this document is subject to change without notice.

ABSOLUTE MAXIMUM RATINGS (T_c = 25 °C, unless otherwise specified)

Parameter	Symbol	Ratings	Unit
Forward Current	I _F	10	mA
Reverse Current	I _R	0.5	mA
Operating Case Temperature	T _C	-40 to +85	°C
Storage Temperature	T _{stg}	-55 to +100	°C

ELECTRO-OPTICAL CHARACTERISTICS (T_c = 25 °C, unless otherwise specified)

Parameter	Symbol	Conditions	MIN.	TYP.	MAX.	Unit
Reverse Breakdown Voltage	V _{(BR)R}	I _D = 100 μA	50	70	100	V
Temperature Coefficient of Reverse Breakdown Voltage	δ ^{*1}	T _C = -40 to +85 °C		0.2		%/°C
Dark Current	I _D	V _R = V _{(BR)R} × 0.9		5	25	nA
Multiplied Dark Current	I _{DM}	M = 2 to 10		1	5	nA
Terminal Capacitance	C _t	V _R = V _{(BR)R} × 0.9, f = 1 MHz		0.35	0.60	pF
Cut-off Frequency	f _c	M = 5	2.5			GHz
		M = 10	2.5			
		M = 30	1.0	1.7		
Quantum Efficiency	η	λ = 1 300 nm, M = 1	76	90		%
		λ = 1 550 nm, M = 1	65	77		
Responsivity	S	λ = 1 300 nm, M = 1	0.80	0.94		A/W
		λ = 1 550 nm, M = 1	0.81	0.96		
Multiplication Factor	M	λ = 1 550 nm, I _{po} = 1.0 μA, V _R = V (@ I _D = 1 μA)	30	40		
Excess Noise Factor ^{*2}	X	λ = 1 300 nm, 1 550 nm, I _{po} = 1.0 μA M = 10, f = 35 MHz, B = 1 MHz		0.7		
	F			5		
Effective Detecting Area Size	φE	M = 10, 80 % of Peak	20		30	μm

$$*1 \delta = \frac{V_{(BR)R} < 25 \text{ °C} + \Delta T \text{ °C} > - V_{(BR)R} < 25 \text{ °C} >}{\Delta T \text{ °C} \cdot V_{(BR)R} < 25 \text{ °C} >}$$

$$*2 F = M^X$$

TYPICAL CHARACTERISTICS (T_c = 25 °C, unless otherwise specified)



WAVELENGTH DEPENDENCE OF QUANTUM EFFICIENCY

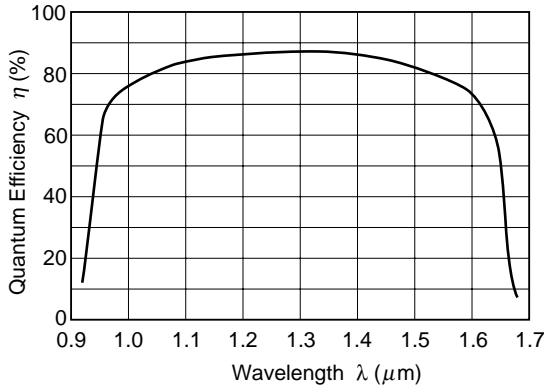

TEMPERATURE DEPENDENCE OF RESPONSIVITY

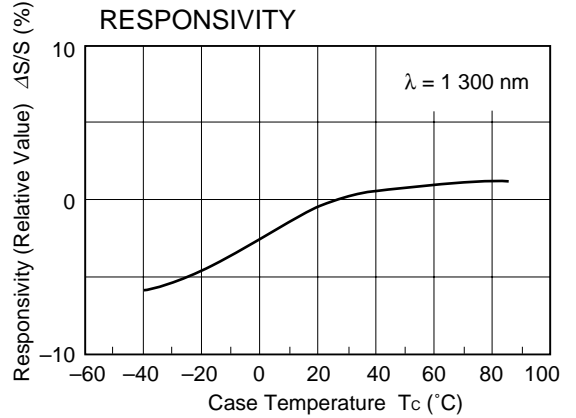

DARK CURRENT and PHOTO CURRENT vs. REVERSE VOLTAGE

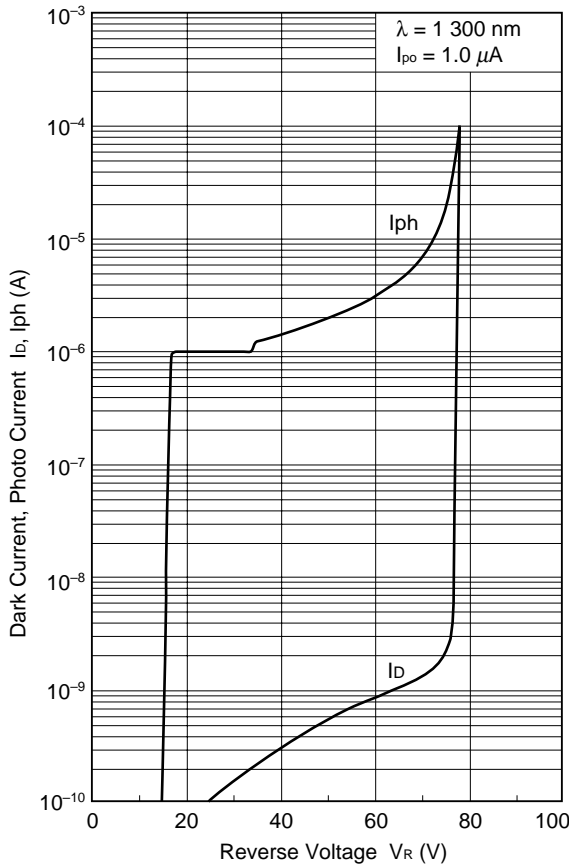

DARK CURRENT vs. REVERSE VOLTAGE

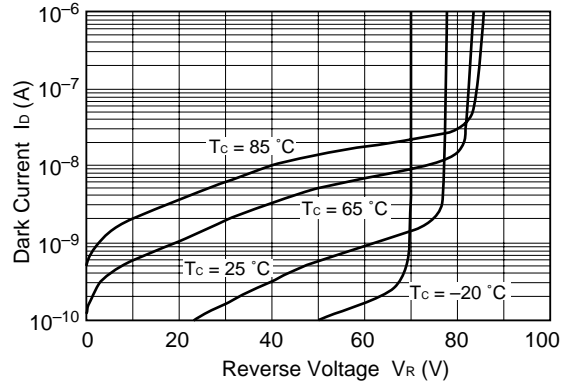

MULTIPLICATION FACTOR vs. REVERSE VOLTAGE

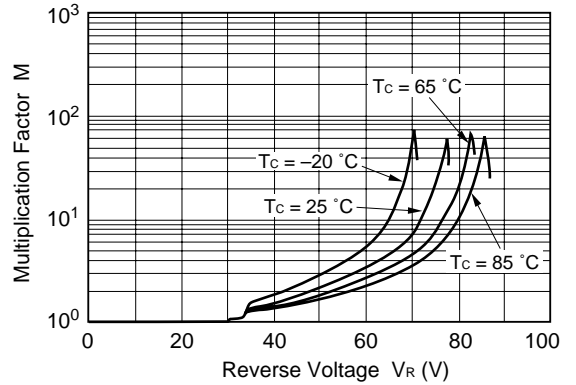

TEMPERATURE DEPENDENCE OF DARK CURRENT vs. MULTIPLIED DARK CURRENT

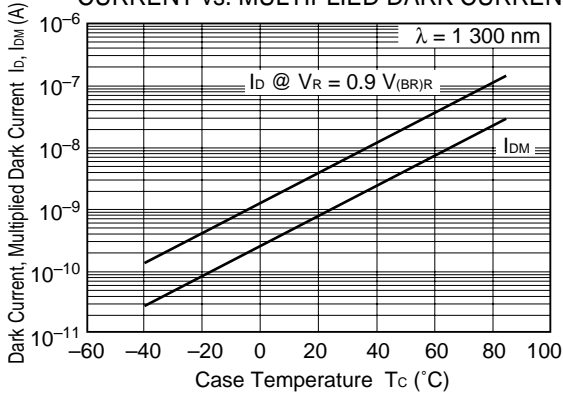

TERMINAL CAPACITANCE vs. REVERSE VOLTAGE

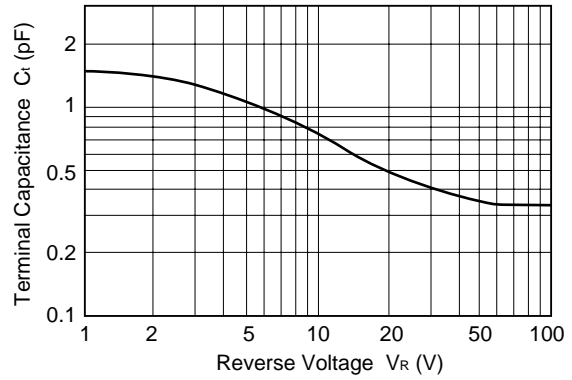

CUT-OFF FREQUENCY vs. MULTIPLICATION FACTOR

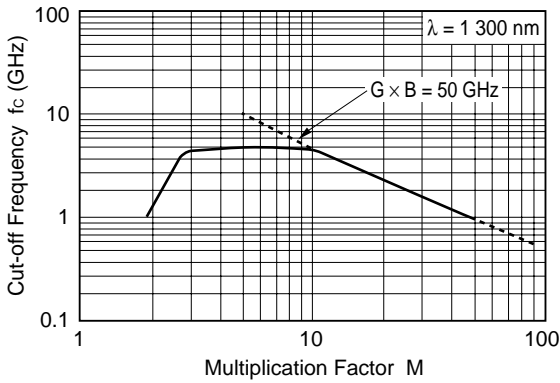

FREQUENCY RESPONSE

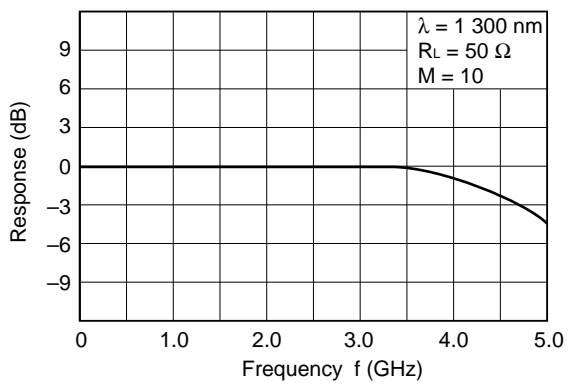

EXCESS NOISE FACTOR vs. MULTIPLICATION FACTOR

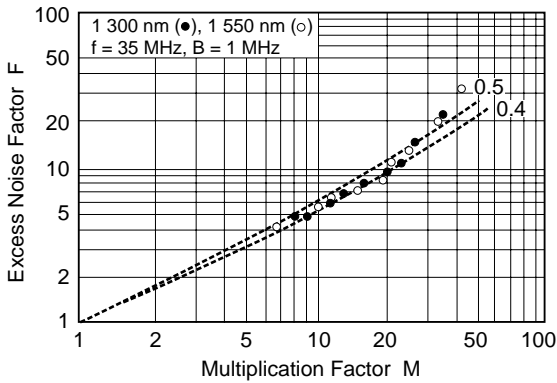

InGaAs APD/PD FAMILY



Features Packages	APD				PIN-PD		Remarks
	ϕ 30 μ m (for 2.5 Gb/s)	ϕ 50 μ m (for 2.5 Gb/s)	ϕ 50 μ m	ϕ 80 μ m	ϕ 50 μ m (for 2.5 Gb/s)	ϕ 80 μ m	
TO-18 type Can	NDL5530	—	NDL5500	NDL5510	—	—	3 pins
TO-18 type Can with Micro Lens	—	—	—	—	NDL5490L ^{*3,4}	NDL5405L	3 pins
Small Can ϕ 5.6 μ m	NDL5531	—	—	—	NDL5490 ^{*3,4}	—	
Chip on Carrier	NDL5530C	NDL5520C	NDL5500C	NDL5510C	—	—	
Receptacle Module	—	—	—	—	—	NDL5471RC NDL5471RD	3 pins RC: FC receptacle RD: SC receptacle
Coaxial Module with MMF	—	NDL5521P NDL5521P1 NDL5521P2	NDL5551P NDL5551P1 NDL5551P2 NDL5553P ^{*1} NDL5553P1 ^{*1} NDL5553P2 ^{*1} NDL5590P NDL5590P1 NDL5590P2	NDL5561P ^{*2} NDL5561P1 ^{*2} NDL5561P2 ^{*2}	NDL5421P NDL5421P1 NDL5421P2	NDL5461P NDL5461P1 NDL5461P2	P1, P2: With flange NDL5590P Series: With Pre-AMP
Coaxial Module with SMF	NDL5531P NDL5531P1 NDL5531P2	—	NDL5553P ^{*1} NDL5553P1S [*] 1 NDL5553P2S [*] 1	—	—	NDL5481P ^{*5} NDL5481P1 ^{*5} NDL5481P2 ^{*5}	
14-pin DIP Module with TEC	—	—	NDL5506P NDL5506PS	—	—	—	$\Delta T = 45$ K (@ $I_c = 1.1$ A) PS: With SMF
6-pin BFY Module with MMF	—	NDL5522P	—	—	NDL5422P	—	With Pre-AMP

*1 For OTDR

*2 With GI-62.5/125

*3 Under development

*4 Internal pre-amplifier for 1 Gb/s

*5 For analog application (optical CATV)

Remark Modules are available with FC-PC connector or optional SC-PC connector.

REFERENCE

Document Name	Document No.
NEC semiconductor device reliability/quality control system	LEI-1201
Quality grades on NEC semiconductor devices	IEI-1209
Semiconductor device mounting technology manual	C10535E
Guide to quality assurance for semiconductor devices	MEI-1202
Semiconductor selection guide	X10679E

[MEMO]

CAUTION

Within this device there exists GaAs (Gallium Arsenide) material which is a harmful substance if ingested. Please do not under any circumstances break the hermetic seal.

The export of this product from Japan is prohibited without governmental license. To export or re-export this product from a country other than Japan may also be prohibited without a license from that country. Please call an NEC sales representative.

No part of this document may be copied or reproduced in any form or by any means without the prior written consent of NEC Corporation. NEC Corporation assumes no responsibility for any errors which may appear in this document.

NEC Corporation does not assume any liability for infringement of patents, copyrights or other intellectual property rights of third parties by or arising from use of a device described herein or any other liability arising from use of such device. No license, either express, implied or otherwise, is granted under any patents, copyrights or other intellectual property rights of NEC Corporation or others.

While NEC Corporation has been making continuous effort to enhance the reliability of its semiconductor devices, the possibility of defects cannot be eliminated entirely. To minimize risks of damage or injury to persons or property arising from a defect in an NEC semiconductor device, customers must incorporate sufficient safety measures in its design, such as redundancy, fire-containment, and anti-failure features.

NEC devices are classified into the following three quality grades:

"Standard", "Special", and "Specific". The Specific quality grade applies only to devices developed based on a customer designated "quality assurance program" for a specific application. The recommended applications of a device depend on its quality grade, as indicated below. Customers must check the quality grade of each device before using it in a particular application.

Standard: Computers, office equipment, communications equipment, test and measurement equipment, audio and visual equipment, home electronic appliances, machine tools, personal electronic equipment and industrial robots

Special: Transportation equipment (automobiles, trains, ships, etc.), traffic control systems, anti-disaster systems, anti-crime systems, safety equipment and medical equipment (not specifically designed for life support)

Specific: Aircrafts, aerospace equipment, submersible repeaters, nuclear reactor control systems, life support systems or medical equipment for life support, etc.

The quality grade of NEC devices is "Standard" unless otherwise specified in NEC's Data Sheets or Data Books. If customers intend to use NEC devices for applications other than those specified for Standard quality grade, they should contact an NEC sales representative in advance.

Anti-radioactive design is not implemented in this product.