

HD74HC423A • Dual Retriggerable Monostable Multivibrators

This multivibrator features output-pulse-duration control by two methods. The basic pulse duration is programmed by selection of external resistance and capacitance values. Once triggered, the basic pulse duration may be extended by re-triggering the gated low-level-active (A) or high-level-active (B) inputs, or be reduced by use of the overriding clear. The B input is a Schmitt trigger enabling jitter-free triggering from input signals with slow transition rates.

FEATURES

- High Speed Operation
- High Output Current: Fanout of 10 LSTTL Loads
- Wide Operating Voltage: $V_{CC}=2\sim 6V$
- Low Input Current: $1\mu A$ max.
- Low Quiescent Supply Current

PIN ARRANGEMENT

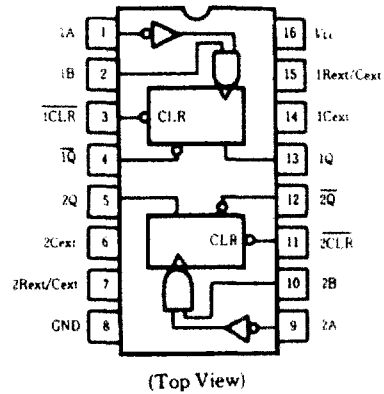

FUNCTION TABLE

Inputs			Output	
Clear	A	B	Q	\bar{Q}
L	x	x	L	H
x	H	x	L	H
x	x	L	L	H
H	L			
H		H		

LOGIC DIAGRAM

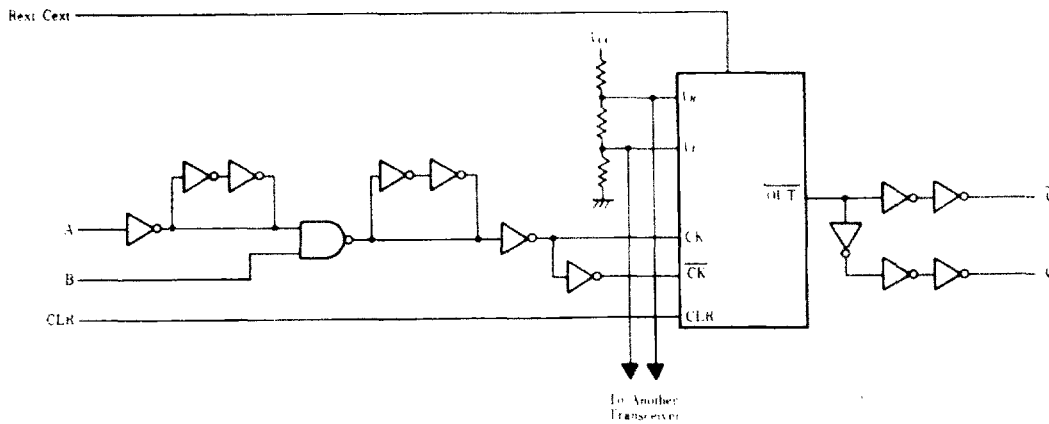

HD74HC423A

DC CHARACTERISTICS

Item	Symbol	V _{CC} (V)	Test Conditions	T _a =25°C			T _a =-40~+85°C		Unit		
				min	typ	max	min	max			
Input Voltage	V _{IH}	2.0		1.5	—	—	1.5	—	V		
		4.5		3.15	—	—	3.15	—			
		6.0		4.2	—	—	4.2	—			
	V _{IL}	2.0		—	—	0.5	—	0.5	V		
		4.5		—	—	1.35	—	1.35			
		6.0		—	—	1.8	—	1.8			
Output Voltage	V _{OH}	2.0	V _{in} =V _{IH} or V _{IL}	I _{OH} =-20μA	1.9	2.0	—	1.9	—	V	
		4.5			4.4	4.5	—	4.4	—		
		6.0			5.9	6.0	—	5.9	—		
		I _{OH} =-4mA		4.5	4.18	—	—	4.13	—		
				6.0	5.68	—	—	5.63	—		
				I _{OH} =-5.2mA	5.68	—	—	5.63	—		
	V _{OL}	V _{in} =V _{IH} or V _{IL}	I _{OL} =20μA	2.0	—	0.0	0.1	—	0.1	V	
				4.5	—	0.0	0.1	—	0.1		
				6.0	—	0.0	0.1	—	0.1		
			I _{OL} =4mA	4.5	—	—	0.26	—	0.33		
				6.0	—	—	0.26	—	0.33		
				I _{OL} =5.2mA	—	—	0.26	—	0.33		
Input Current	I _{in}	6.0	V _{in} =V _{CC} or GND	—	—	±0.1	—	±1.0	μA		
Quiescent Supply Current	Standby State	I _{CC}	6.0	V _{in} =V _{CC} or GND	I _{in} =0μA	—	—	130	—	220	μA
	Active State					—	—	130	—	220	

AC CHARACTERISTICS (C_L=50pF, Input t_r=t_f=6ns)

Item	Symbol	V _{CC} (V)	Test Conditions	T _a =25°C			T _a =-40~+85°C		Unit		
				min.	typ.	max.	min.	max.			
Propagation Delay Time	t _{PLH}	2.0	A or B to Q	—	—	210	—	265	ns		
		4.5		—	20	42	—	53			
		6.0		—	—	36	—	45			
	t _{PHL}	4.5	6.0	A or B to \bar{Q}	—	—	240	—	300	ns	
					—	21	48	—	60		
					—	—	41	—	51		
	t _{PNL}	2.0	4.5	Clear to Q	—	—	170	—	215	ns	
					—	17	34	—	43		
					—	—	29	—	37		
		t _{PLM}	2.0	4.5	Clear to \bar{Q}	—	—	180	—	225	ns
						—	15	36	—	45	
						—	—	31	—	38	
Pulse Width	t _w	2.0	A, B, Clear	150	—	—	190	—	ns		
		4.5		30	6	—	38	—			
		6.0		26	—	—	33	—			
Removal Time	t _{rem}	2.0	Clear	0	—	—	5	—	ns		
		4.5		0	-3	—	5	—			
		6.0		0	—	—	5	—			
Minimum Output Pulse Width	t _{WQ(min)}	2.0	C _{ext} =28pF	R _{ext} =6kΩ		—	1.5	—	—	μs	
		4.5		R _{ext} =2kΩ		—	450	—	—	ns	
		6.0				—	380	—	—		
Output Pulse Width	t _{WQ}	4.5	C _{ext} =0.1μF, R _{ext} =10kΩ		—	1.0	—	—	ms		
Output Rise/Fall Time	t _{TLH} t _{TNL}	2.0		—	—	75	—	95	ns		
		4.5		—	5	15	—	19			
		6.0		—	—	13	—	16			
Input Capacitance	C _{in}	—	Pins 7 & 15	—	—	20	—	20	pF		
		—	Other Pins	—	5	10	—	10			

Caution in use : In order to prevent any malfunctions due to noise, connect a highfrequency performance capacitor between V_{CC} and GND, and keep the wiring between the External components and C_{ext}, R_{ext}/C_{ext} pins as short as possible.