

Unity gain level programmable low power compandor

NE/SA578

DESCRIPTION

The NE/SA578 is a unity gain level programmable compandor designed for low power applications. The NE578 is internally configured as an expander and a compressor to minimize external component count.

The summing amplifiers of the NE578 have 600Ω drive capability and the inverting input of the compressor amplifier is accessible through Pin 9 for summing multiple external signals. Power Down/Mute function is active low and requires an open collector output logic configuration at Pin 8. If Power Down/Mute is not needed, Pin 8 should be left open. When the part is muted, supply current drops to 170mA at 3.6V. The NE578 is available in a 16-pin plastic DIP and SO packages.

FEATURES

- Operating voltage range: 1.8V to 7V
- Low power consumption (1.4mA @ 3.6V)
- 0dB level programmable (10mV_{RMS} to 1.0V_{RMS})
- Over 90dB of dynamic range
- Wide input/output swing capability
- Low external component count
- SA578 meets cellular radio specifications
- ESD hardened
- Power Down mode (I_{CC} = 170μA @ 3.6V)
- Mute function
- Multiple external summing capability
- 600Ω drive capability

PIN CONFIGURATION

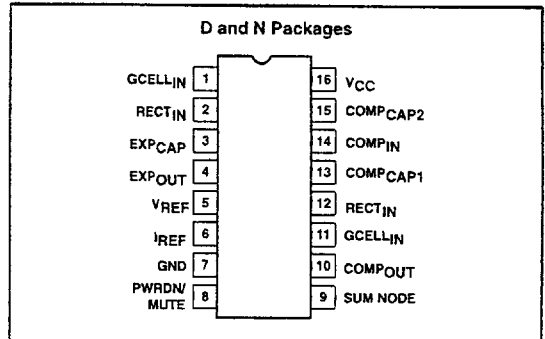

APPLICATIONS

- High performance portable communications
- Cellular radio
- Cordless telephone
- Consumer audio
- Wireless microphones
- Modems
- Electric organs
- Hearing aids
- Automatic level control (ALC)

ORDERING INFORMATION

DESCRIPTION	TEMPERATURE RANGE	ORDER CODE	DWG #
16-Pin Plastic Dual In-Line Package (DIP)	0 to +70°C	NE578N	0406C
16-Pin Plastic Small Outline (SO)	0 to +70°C	NE578D	0005D
16-Pin Plastic Dual In-Line Package (DIP)	-40 to +85°C	SA578N	0406C
16-Pin Plastic Small Outline (SO)	-40 to +85°C	SA578D	0005D

ABSOLUTE MAXIMUM RATINGS

SYMBOL	PARAMETER	RATING		UNITS
		NE578	SA578	
V _{CC}	Supply voltage	8	8	V
T _A	Operating ambient temperature range	0 to +70	-40 to +85	°C
T _{STG}	Storage temperature range	-65 to +150	-65 to +150	°C
θ _{JA}	Thermal impedance	DIP	90	°C/W
		SO	125	°C/W

Unity gain level programmable
low power compandor

NE/SA578

BLOCK DIAGRAM and TEST AND APPLICATION CIRCUIT

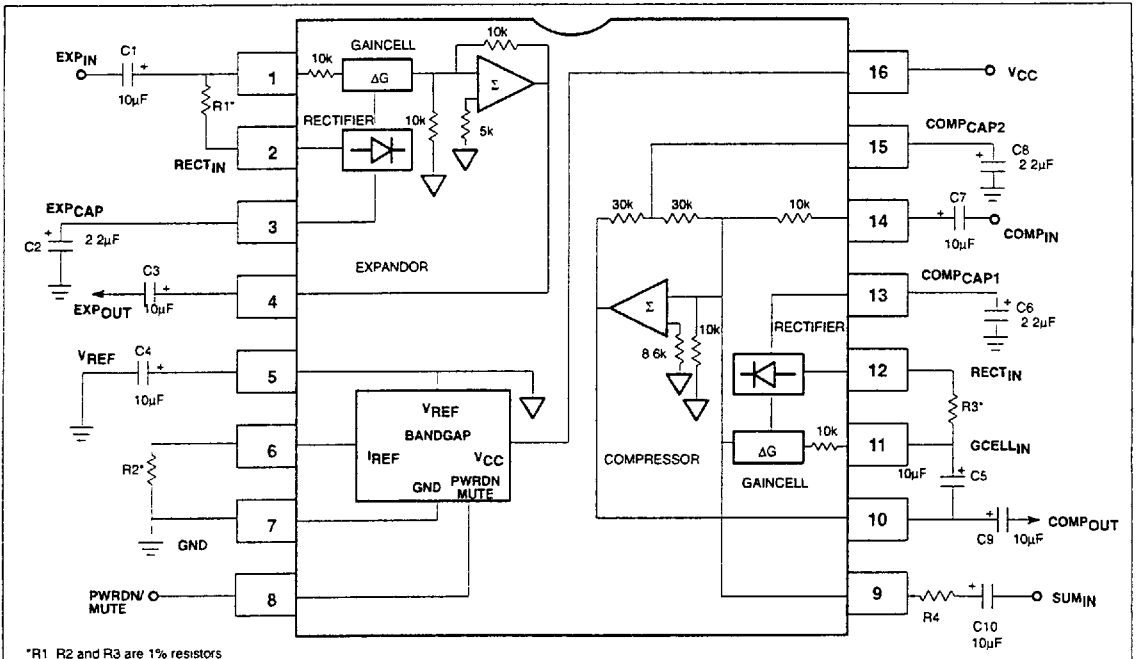

Unity gain level programmable low power compandor

NE/SA578

ELECTRICAL CHARACTERISTICS

$T_A = 25^\circ\text{C}$, $V_{CC} = 3.6\text{VDC}$, compandor 0dB level = $-20\text{dBV} = 100\text{mV}_{\text{RMS}}$, output load $R_L = 10\text{k}\Omega$, Freq = 1kHz , unless otherwise specified
R1, R2 and R3 are 1% resistors.

SYMBOL	PARAMETER	TEST CONDITIONS	LIMITS			UNITS
			NE/SA578			
			MIN	TYP	MAX	
V_{CC}	Supply voltage ¹		2	3.6	7	V
I_{CC}	Supply current operating power down	No signal, $R_2 = 100\text{k}\Omega$		1.4 170	2	mA μA
V_{REF}	Reference voltage ²	$V_{CC} = 3.6\text{V}$	1.7	1.8	1.9	V
R_L	Summing amp minimum output load			600		Ω
THD	Total harmonic distortion	1kHz , 0dB, BW = 3.5kHz		0.25	1.0	%
E_{NO}	Expandor output noise voltage	BW = 20kHz , $R_S = 0\Omega$		10	20	μV
0dB	Unity gain level	0dB at 1kHz	-1.0	0.18	1.0	dB
	Programmable range ³	$R_1 = R_3 = 18.7\text{k}\Omega$, $R_2 = 24.3\text{k}\Omega$		0		dBV
		$R_1 = R_3 = 22.6\text{k}\Omega$, $R_2 = 100\text{k}\Omega$		-10		
		$R_1 = R_3 = 7.15\text{k}\Omega$, $R_2 = 100\text{k}\Omega$		-20		
		$R_1 = R_3 = 1.33\text{k}\Omega$, $R_2 = 200\text{k}\Omega$		-40		
V_{OS}	Output voltage offset	No signal	-150	1	150	mV
	Expandor output DC shift	No signal to 0dB	-100	7	100	mV
	Tracking error relative to 0dB output	-20dB expandor	-1.0	0.3	1.0	dB
	Crosstalk, COMP to EXP	1kHz , 0dB, $C_{REF} = 10\mu\text{F}$		-80	-65	dB
V_O	Output swing low			0.2		V
	Output swing high			$V_{CC} - 0.2$		
	Power Down/Mute low level		0		0.4	V
	Power Down/Mute input current	Pin 8 grounded		-65		μA

NOTE:

1. Operation down to $V_{CC} = 1.8\text{V}$ is possible, see application note AN1762
2. Reference voltage, V_{REF} is typically at $1/2 V_{CC}$
3. Unity gain level can be adjusted CONTINUOUSLY between $-40\text{dBV} = 10\text{mV}_{\text{RMS}}$ and $0\text{dBV} = 1.0\text{V}_{\text{RMS}}$. For details see application note AN1762.

Unity gain level programmable low power compandor

NE/SA578

TYPICAL PERFORMANCE CHARACTERISTICS

$V_{CC} = 3.6V$, $T_A = 25^\circ C$, $R_1=R_3=7.15k\Omega$, $R_2=100k\Omega$, $0dB$ level = 100mV, Freq = 1kHz

