

AK5345

16bit ADC

- ① +5.0V single supply 16 bit 2ch A/D Converter
- ② 4th Order Delta-Sigma A/D Converter
- ③ On-chip Digital Anti-Alias Filter
- ④ On-chip S/H circuitry and Voltage Reference
- ⑤ 64 X over sampling
- ⑥ 2ch Simultaneous Sampling
- ⑦ S/N: 91dB
- ⑧ Serial Interface
- ⑨ Low Power Dissipation: 100mW
- ⑩ Low Voltage Operation: +4.5V to 5.5V
- ⑪ Compatible with AK5343 & AK5344
- ⑫ Package: 28 pin SOP (7.5×18.7×2.2mm)

AK5350

20bit ADC



28pin VSOP (5.6×9.8×1.2mm)

- ① Sampling rate: max. 54kHz
- ② Full-differential inputs
- ③ S/ (N+D): 94dB
- ④ DR, S/N: 100dB
- ⑤ Linear phase digital filter
 - Pass band: 0~22kHz (@fs=48kHz)
 - Pass band ripple: ± 0.01dB
 - Stop band attenuation: 80dB
- ⑥ Digital HPF for DC-offset cancel
- ⑦ Master clock: 256fs/384fs
- ⑧ Power supply: 5V±10%
- ⑨ Low power consumption: 115mW
- ⑩ Package: 28pin VSOP

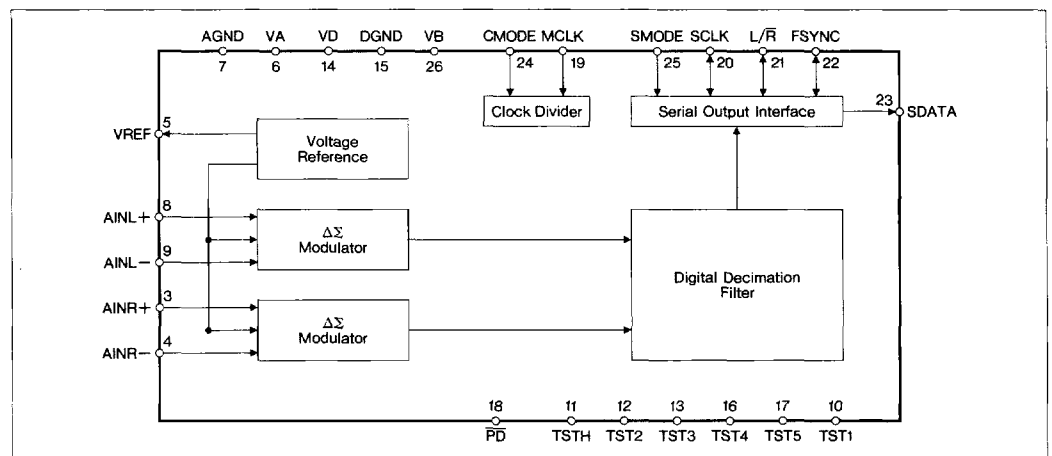

AK5350 BLOCK DIAGRAM

AKD5350

AK5350 Evaluation Board

The AKD5350 is an evaluation board for the AK5350 digital stereo audio 20bit A/D converter. The AKD5350 includes the input buffer circuit and also has a digital interface transmitter. Further, the AKD5350 can evaluate direct interface with AKD4328, AKD4303, AKD4310, AKD4311, AKD4320 and AKD4319.

- ① On-board Full-differential input buffer circuit
- ② On-board clock generator
- ③ Compatible with 2 types of interface
 - Direct interface with AKD4328, AKD4303, AKD4310, AKD4311, AKD4320 and AKD4319.
 - On-board CS8402 as DIT which transmits optical output.
- ④ BNC connector for an external clock input.