

## MIL-C-83517/9\*

Disclosure Notice: Qualification has not been completed and the manufacturing facility has not been certified by the qualifying agency and these products are not yet covered by the QPL/QML.

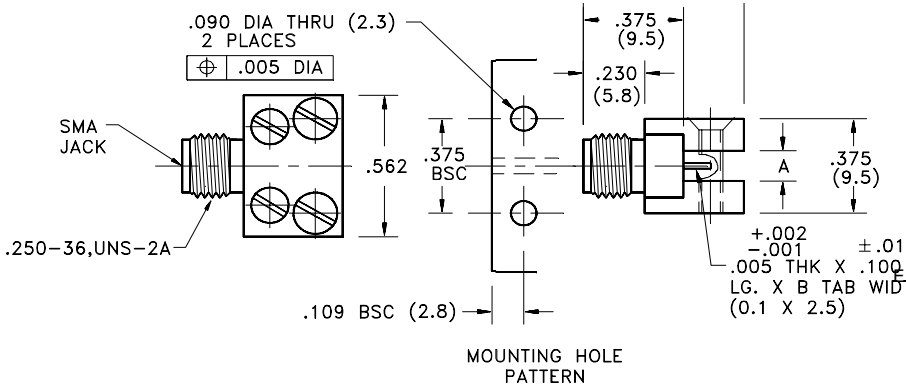

FIGURE 1

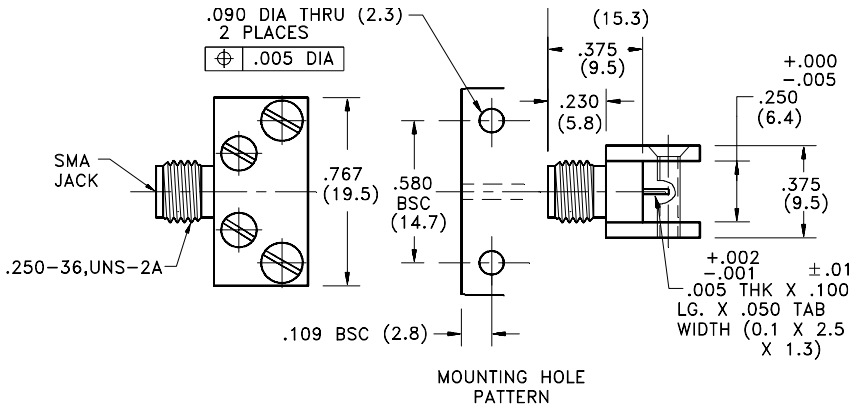

FIGURE 2

MILITARY PART NO.	MIDWEST PART NO	FIGURE	DIMENSION A Inches (mm)	DIMENSION B Inches (mm)	COMMERCIAL ALTERNATE
- 31001		1	.057/.064 (1.4/1.6)	.025 (0.6)	SMA-0063-48-000-02
- 31002		1	.120/.127 (3.0/3.2)	.050 (1.3)	SMA-0125-48-000-02
- 31003		1	.245/.250 (6.2/6.4)	.050 (1.3)	SMA-0250-48-000-02
- 31004		2	N/A	N/A	SMA-0250-48-001-02
- 32001		1	.057/.064 (1.4/1.6)	.025 (0.6)	SMA-0063-48-000-00
- 32002		1	.120/.127 (3.0/3.2)	.050 (1.3)	SMA-0125-48-000-00
- 32003		1	.245/.250 (6.2/6.4)	.050 (1.3)	SMA-0250-48-000-00
- 32004		2	N/A	N/A	SMA-0250-48-001-00

Notes:  
 1. \* Qualification to MIL-C-83517 is in-process at time of printing. Please contact Midwest Microwave for current status.  
 2. See Appendix for description of connector interfaces .