

HB66A51216CA-25

1,048,576Word×8bit /524,288Word×16bit
High Density CMOS Static RAM Card

Rev.0
jul.10,1992



The HB66A51216CA-25 is a high density 1MWord×8bit or 512kWord×16bit static RAM Card, mounted of 8pieces 1M static RAM sealed in TSOP package.

An outline of the HB66A51216CA-25 is 68-pin two piece connector package.

Therefore, the HB66A51216CA-25 makes high density and it is possible to expand easily for memory system.

■ Features

- Type HB66A51216CA-25
- Memory capacity 1MWord×8bit
512kWord×16bit
- Attribute Memory 512Word×8bit
- Power supply +5V(±5%)
- Memory backup battery CR2025 1pcs. (replaceable)
- Memory retention period 2year (Ta=+20°C)
- Interface Parallel I/O interface
- Standard weight 30g
- Operating temperature 0 to +55°C, 95%RH or less
- Product code To be stamped on the product
- High speed 250ns(max.)
- Compatibility JEIDA 4.1 / PCMCIA 2.0

■ Ordering information

Part no.	Access time	Package
HB66A51216CA-25	250ns	68-pin 2piece connector

M12T052

■ Pin out

Pin Name	Pin No.		Pin No.	Pin Name
GND	1	○ ○	35	GND
D3	2	○ ○	36	/CD1
D4	3	○ ○	37	D11
D5	4	○ ○	38	D12
D6	5	○ ○	39	D13
D7	6	○ ○	40	D14
/CE1	7	○ ○	41	D15
A10	8	○ ○	42	/CE2
/OE	9	○ ○	43	NC
A11	10	○ ○	44	NC
A9	11	○ ○	45	NC
A8	12	○ ○	46	A17
A13	13	○ ○	47	A18
A14	14	○ ○	48	A19
/WE	15	○ ○	49	NC
NC	16	○ ○	50	NC
Vcc	17	○ ○	51	Vcc
NC	18	○ ○	52	NC
A16	19	○ ○	53	NC
A15	20	○ ○	54	NC
A12	21	○ ○	55	NC
A7	22	○ ○	56	NC
A6	23	○ ○	57	NC
A5	24	○ ○	58	NC
A4	25	○ ○	59	NC
A3	26	○ ○	60	NC
A2	27	○ ○	61	/REG
A1	28	○ ○	62	BVD2
A0	29	○ ○	63	BVD1
D0	30	○ ○	64	D8
D1	31	○ ○	65	D9
D2	32	○ ○	66	D10
WP	33	○ ○	67	/CD2
GND	34	○ ○	68	GND

■ Pin Description

Pin Name	Function
/WE	Write Enable
/OE	Output Enable
A0 to A19	Address Input
D0 to D15	Data-input/output
/CE1, /CE2	Chip Enable
/CD1, /CD2	Card Detect
Vcc	+5V Supply
GND	Ground
WP	Write Protect
REG	Attribute memory select
BVD1, BVD2	Battery Voltage Detect
NC	No connect

Note)

1. NC pins are open. Be sure to keep this terminal open on the system side. The terminals indicated below may be used on the system side because their functions are already specified.
 - #18: Vpp1 (Supply voltage for program (even bytes))
 - #52: Vpp2 (Supply voltage for program (odd bytes))
 - #49: A20, #50: A21, #53: A22, #54: A23, #55: A24, #56: A25
2. When one or both of the /CE1, and /CE2 signals are supplied high, set all input signals high or low. The same may be with input/output signals which are in the input state (to avoid the high impedance state).

Block Diagram

Note :

- U1 to U8 :1Mbit SRAM
- U9 :Gate Array A
- U10 :Gate Array B
- U11 :Power Supply Voltage Detection IC
- R1 to R15 :100kΩ
- R16 :56kΩ
- R17 :1kΩ
- R18,R19 :1MΩ
- C1 to C7 :0.1μF
- C8 :2700pF
- C9 :12000pF
- C10 :3.3μF
- D1 to D3 :Diodes
- SW :Slide Switch
- CN :68Pin Connector
- BAT1 :CR2025
- U13,U14,U18,U17 :OR Gate
- U15 :AND Gate
- U12 :EEPROM

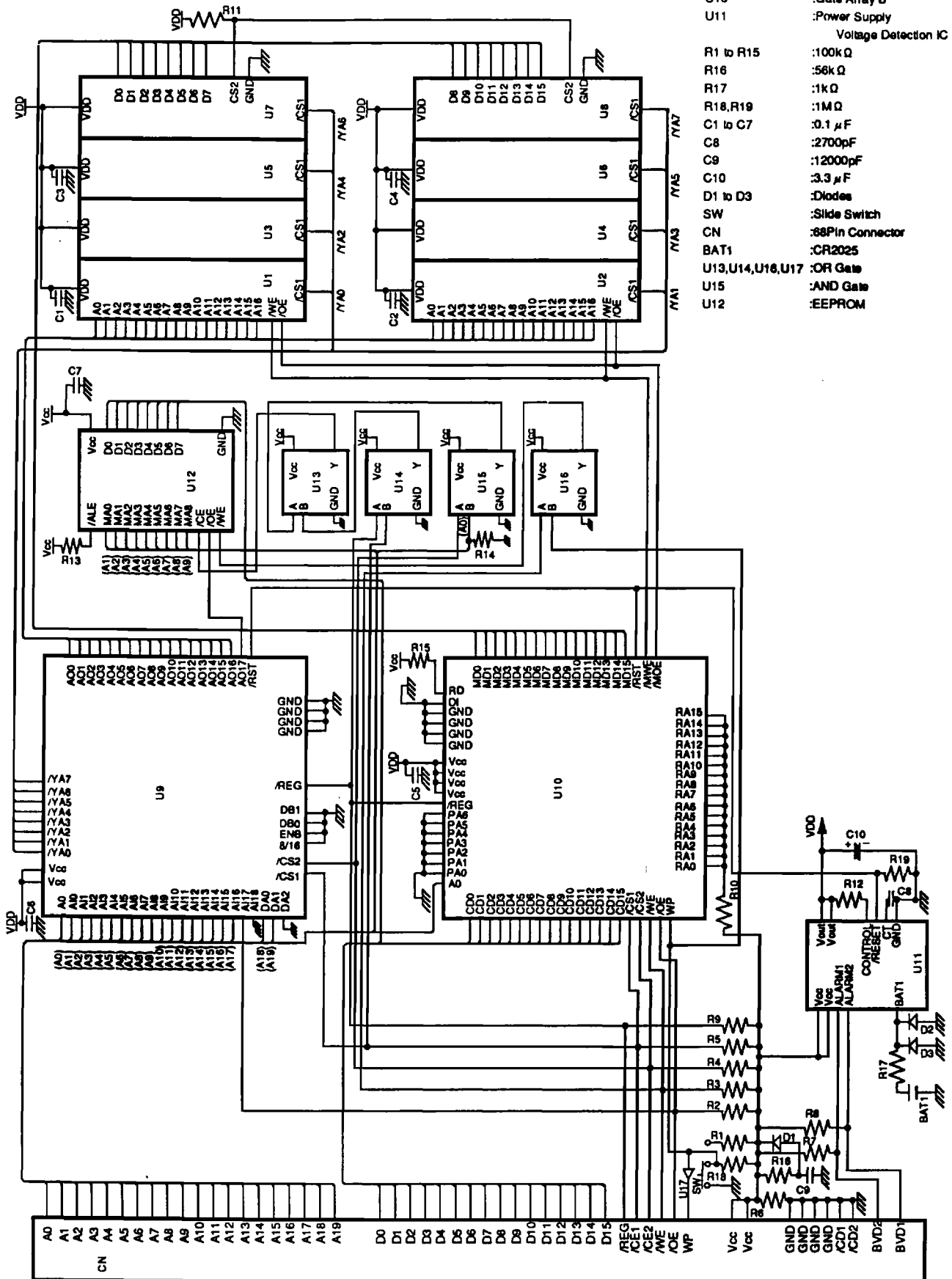

Physical Outline

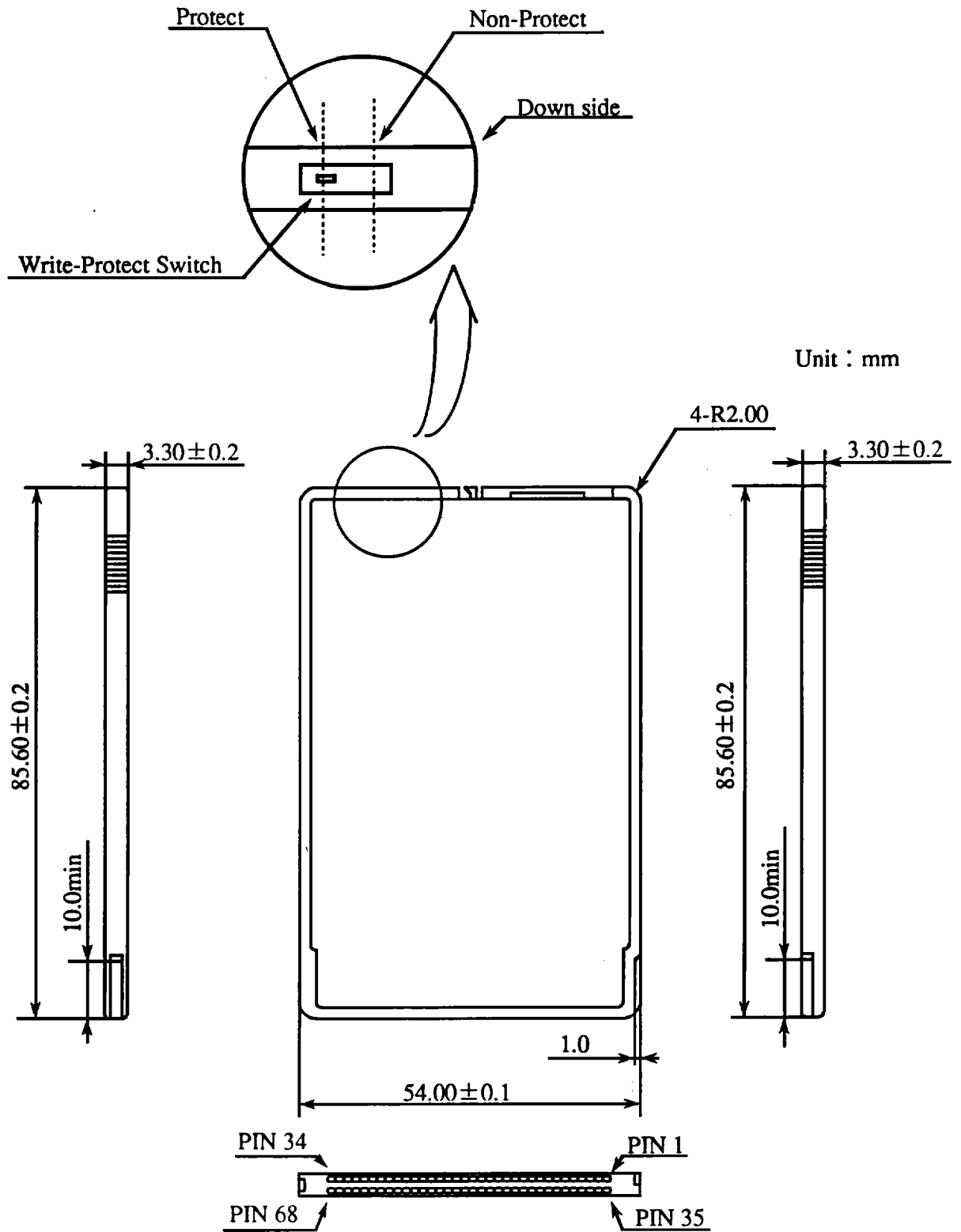

■ Function Table

/CE1	/CE2	A0	/WE	/OE	/REG	Mode	D0~D7	D8~D15	Status
H	H	×	×	×	H	Not select	High-Z	High-Z	Stand by
L	H	L	H	L	H	Read (×8)	Do(Even)	High-Z	Active
L	H	H	H	L	H	Read (×8)	Do(Odd)	High-Z	Active
L	H	L	L	×	H	Write (×8)	Di (Even)	High-Z	Active
L	H	H	L	×	H	Write (×8)	Di (Odd)	High-Z	Active
H	L	×	L	×	H	Write (×8)	High-Z	Di (odd)	Active
H	L	×	H	L	H	Read (×8)	High-Z	Do(odd)	Active
L	L	×	H	L	H	Read (×16)	Do(Even)	Do(odd)	Active
L	L	×	L	×	H	Write (×16)	Di (Even)	Di (odd)	Active
×	L	×	H	H	H	Output disable	High-Z	High-Z	Active
L	H	×	H	H	H	Output disable	High-Z	High-Z	Active

H:High level L:Low level ×:Either "H"or "L"
 Di:Input data Do:Output data

Note)

1. When the write protect switch is turned to the protect side, no data can be written and the WP signal goes high.
2. Attribute memory addresses are from A0 to A9. A10 and more addresses are not used.

■ Absolute Maximum Ratings

Parameter	Symbol	Min.	Typ.	Max.	Unit
Power supply voltage	Vcc	-0.5	5.0	7.0	V
Input/Output voltage	VI	-0.5	-	Vcc+0.5 (max. 7.0)	V

■ Recommended DC Operating Conditions (Ta=0 to +55°C)

Parameter	Symbol	Min.	Typ.	Max.	Unit
Supply voltage	Vcc	4.75	5.0	5.25	V
	Vss	0	0	0	V
Input high voltage	ViH	Vcc×0.3	-	Vcc+0.3	V
Input low voltage	ViL	-0.3	-	0.8	V

■ DC Characteristics ($V_{cc}=5V \pm 5\%$, $T_a=0$ to $+55^\circ C$)

Parameter	Symbol	Min.	Typ.	Max.	Unit	Test Conditions
Standby power supply current	I_{sB1}	-	-	2.0	mA	*Note1)-2
Operating power supply current	I_{cc1}	-	-	200	mA	
Input current	A0 to A19 D0 to D15	-10	-	10	μA	$V_I=V_{cc}$ or GND
	/CE1, /CE2, /OE /WE, /REG	-70	-	70	μA	$V_I=V_{cc}$ or GND
Output voltage *Note1)-1	VOH	$V_{cc}-0.4$	-	-	V	$I_{OH}=-12mA$
	VOL	-	-	0.4	V	$I_{OL}=12mA$

Note1)

1. Except WP signal, /CD1 signal, /CD2 signal, BVD1 signal, BVD2 signal.
2. Set the power supply voltage for the memory card to 5.0V. Set the /CE1, /CE2, /OE, /WE, and /REG signal to the high level ($V_{IH} \geq V_{cc}-0.2V$) and the A0 signal to the low level ($V_{IL} \leq 0.2V$). Then measure the current. (The output signal is open.)
3. Set the power supply voltage for the memory card to 5.0V. Measure the current when the memory card is accessed. (The access time is 250ns.)

■ Capacitance ($T_a=+25^\circ C$, $f=1MHz$)

Parameter	Symbol	Typ.	Max.	Unit	Test Conditions
Input capacitance	C_{in}	-	10	pF	$V_{cc}=V_I=GND$
Input/Output capacitance	CI/O	-	35	pF	$V_{cc}=V_I=GND$

Note2)

Input capacitance of A0 signal, /CE1 signal, /CE2 signal, /OE signal and /REG signal are 20pF Max.

■ AC Characteristics(Ta=0 to +55°C, Vcc=5V±5%)

AC Test condition

- Input pulse level : 0.8 to 3.5V
- Input pulse rise and fall time : 10ns
- Input and output timing reference level : 1.5V
- Output load : 1TTL Gate and CL=100pF
(Including scope and jig capacitance)

● Read Cycle

Parameter	Symbol	Standard		Unit
		Min.	Max.	
Read cycle time	tCR	250	-	ns
Address access time	ta(A)	-	250	ns
Card enable access time	ta(CE)	-	250	ns
Output enable time	ta(OE)	-	125	ns
Output disable time from /CE1, /CE2	tdis(CE)	-	100	ns
Output disable time from /OE	tdis(OE)	-	100	ns
Output enable time from /CE1, /CE2	ten(CE)	5	-	ns
Output enable time	ten(OE)	5	-	ns
Data valid from address change	tv(A)	0	-	ns

● Read Cycle Timing (1) (/CE2=V_{IH} fixing) 8bits output

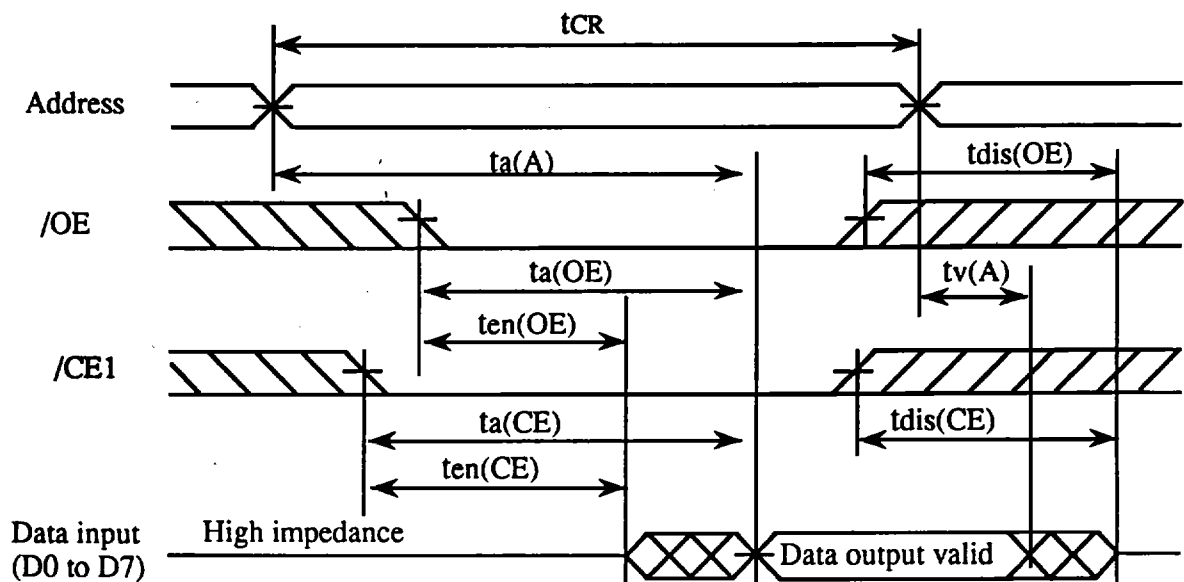

Note3)

1. During the read cycle, set the /WE signal high.
2. The hatched part may be either high or low.

● Read Cycle Timing (2) (/CE1=VIH fixing) 8bits output

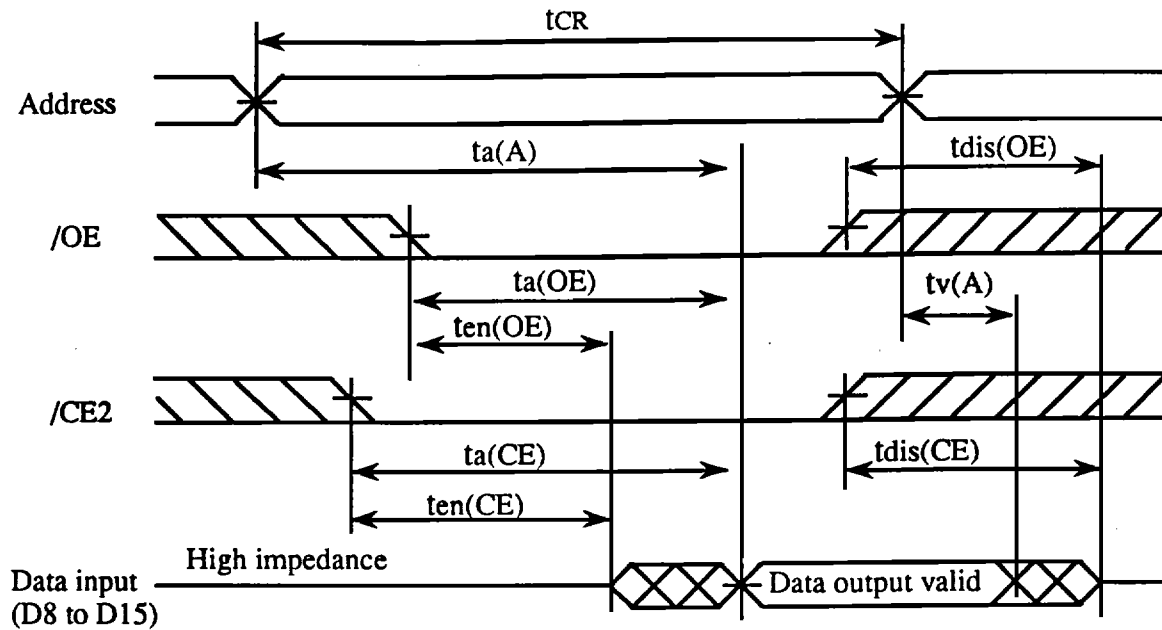

Note4)

1. During the read cycle, set the /WE signal high.
2. The hatched part may be either high or low.

● Read Cycle Timing (3) 16bits output

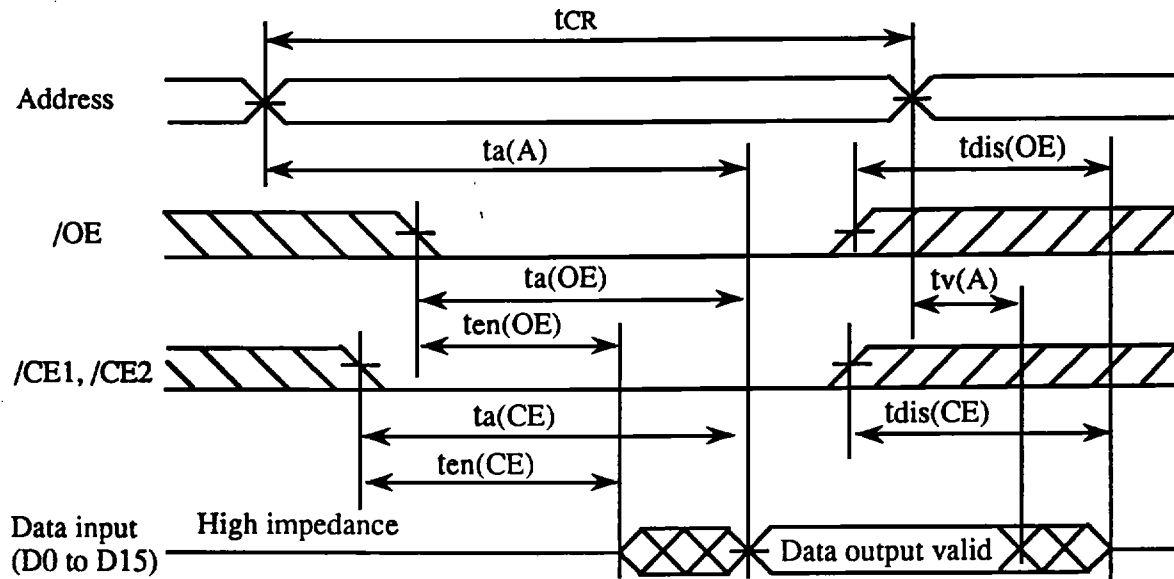

Note5)

1. During the read cycle, set the /WE signal high.
2. The hatched part may be either high or low.
3. Change the /CE1 signal and the /CE2 signal simultaneously.

● Write Cycle

Parameter	Symbol	Standard		Unit
		Min.	Max.	
Write cycle time	t_{CW}	250	-	ns
Write pulse width	$t_{W(WE)}$	150	-	ns
Address setup time	$t_{SU(A)}$	30	-	ns
Address setup time for /WE	$t_{SU(A-WEH)}$	180	-	ns
Card enable setup time for /WE	$t_{SU(CE)}$	180	-	ns
Data setup time for /WE	$t_{SU(D)}$	80	-	ns
Data hold time	$t_{h(D)}$	30	-	ns
Write recover time	$t_{rec(WE)}$	30	-	ns
Output disable time from /WE	$t_{dis(WE)}$	-	100	ns
Output disable time from /OE	$t_{dis(OE)}$	-	100	ns
Output enable time from /WE	$t_{en(WE)}$	5	-	ns
Output enable time from /OE	$t_{en(OE)}$	5	-	ns

● Write Cycle Timing (1) (/CE2=V_{IH} fixing) 8bits output (/WEcontrol)

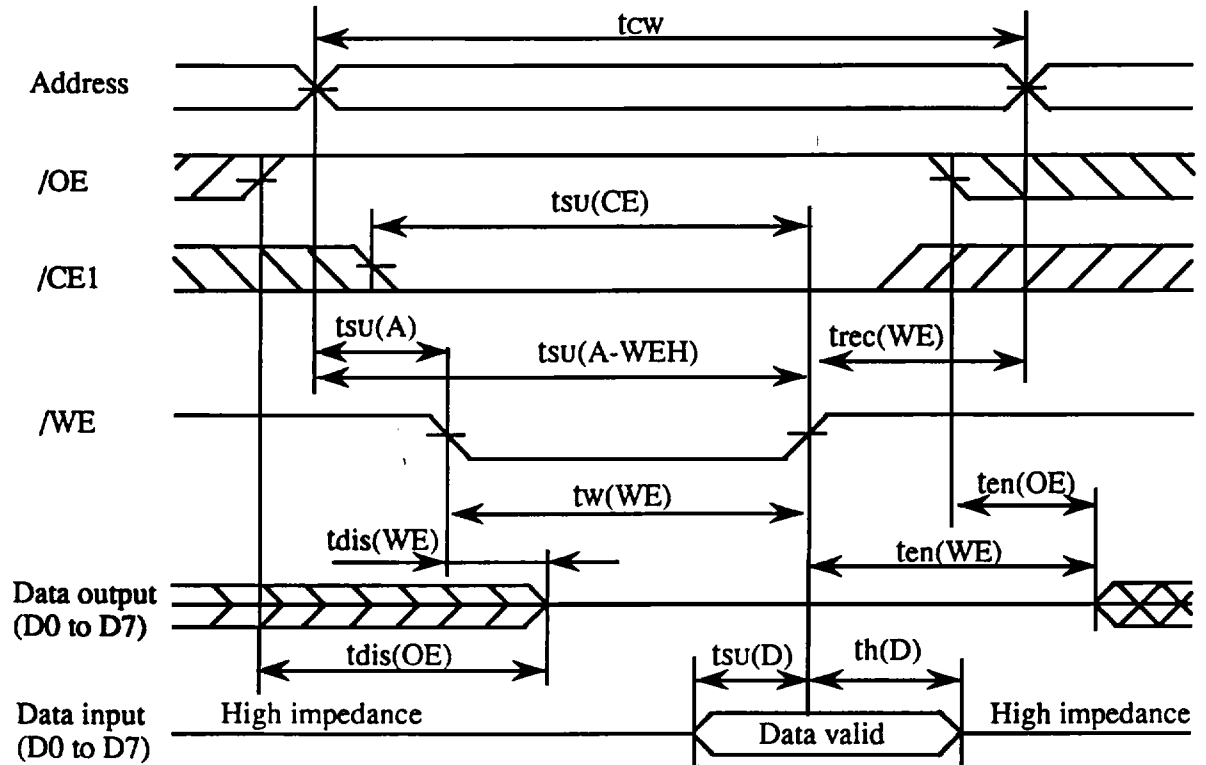

Note6)

1. Data is written when the /CE1 signal is low and the /WE signal is low and overlapped ($t_{W(WE)}$).
2. When a data signal is in the output state, do not apply an input signal in a reverse phase to the output.
3. The hatched part may be either high or low.

● Write Cycle Timing (2) (/CE1=VIH fixing) 8bits output (/WE control)

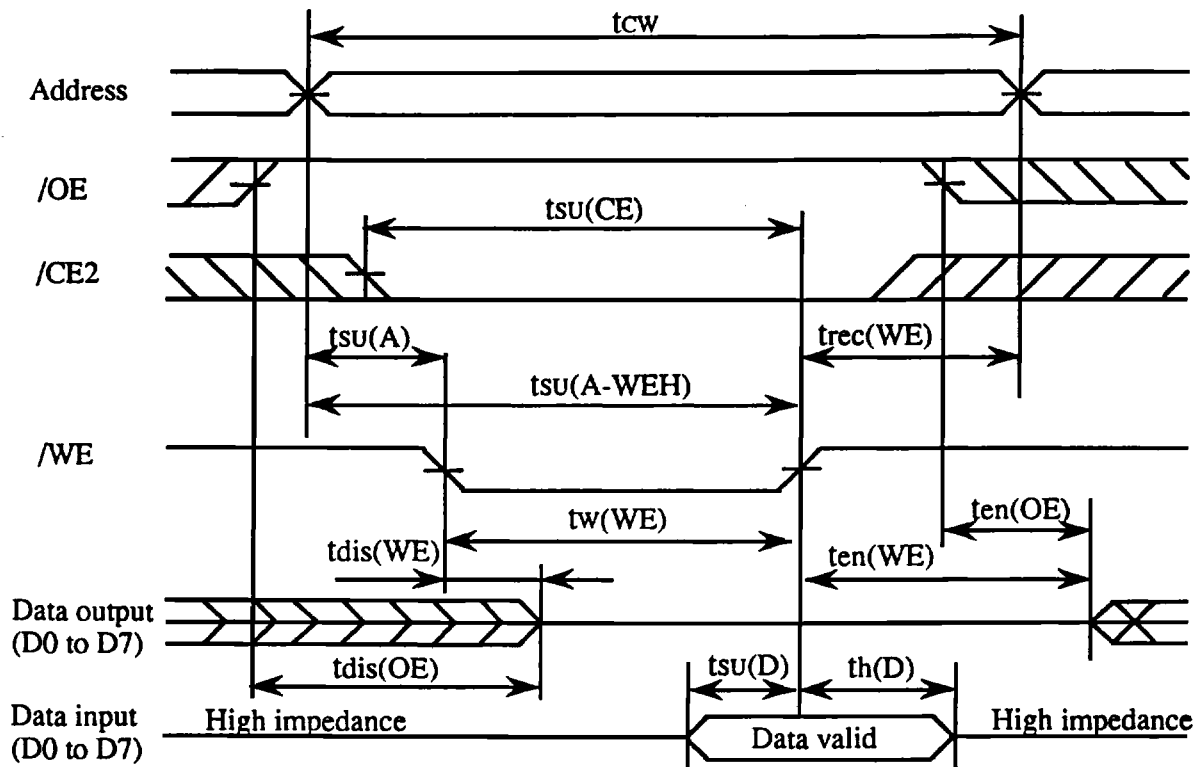

Note7)

1. Data is written when the /CE2 signal is low and the /WE signal is low and overlapped ($t_{w}(WE)$).
2. When a data signal is in the output state, do not apply an input signal in a reverse phase to the output.
3. The hatched part may be either high or low.

● Write Cycle Timing (3) 16bits output (/WE control)

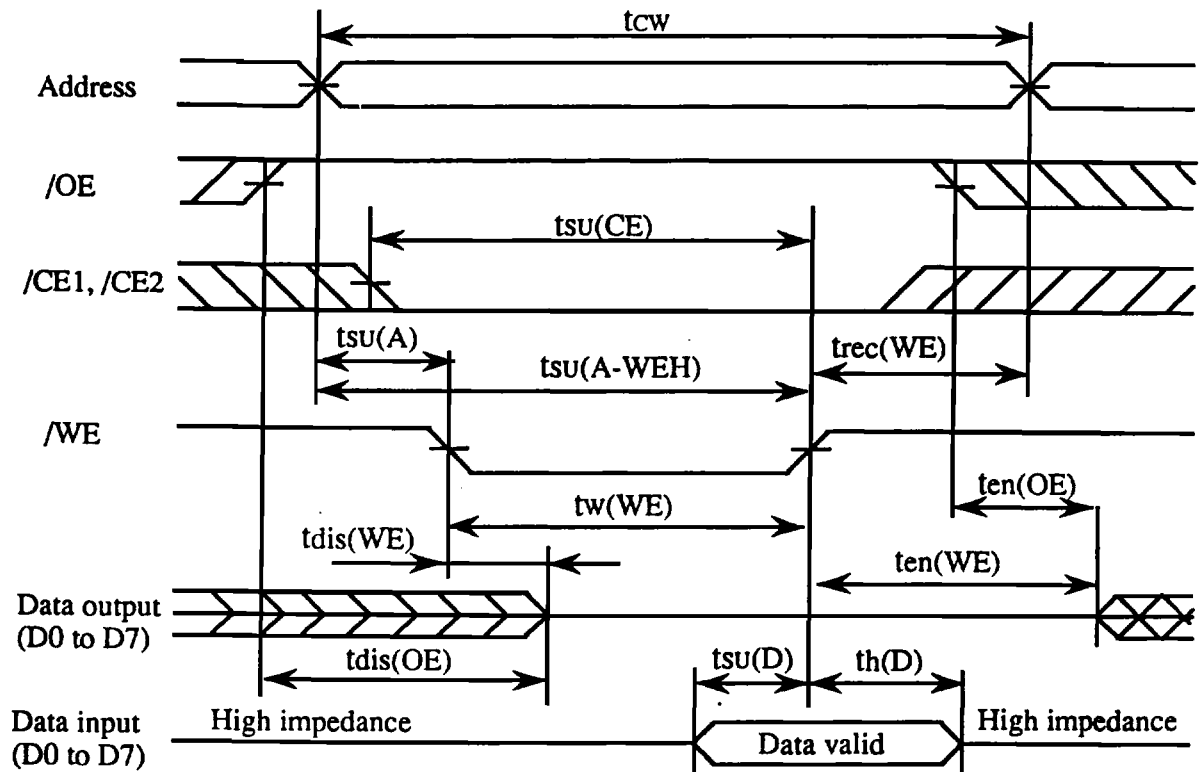

Note8)

1. Data is written when the /CE1 and /CE2 signal is low and the /WE signal is low and overlapped ($t_w(WE)$).
2. When a data signal is in the output state, do not apply an input signal in a reverse phase to the output.
3. The hatched part may be either high or low.
4. Change the /CE1 signal and the /CE2 signal simultaneously.

● Write Cycle Timing (4) (/CE2=VIH fixing) 8bits output (/CE1 control)

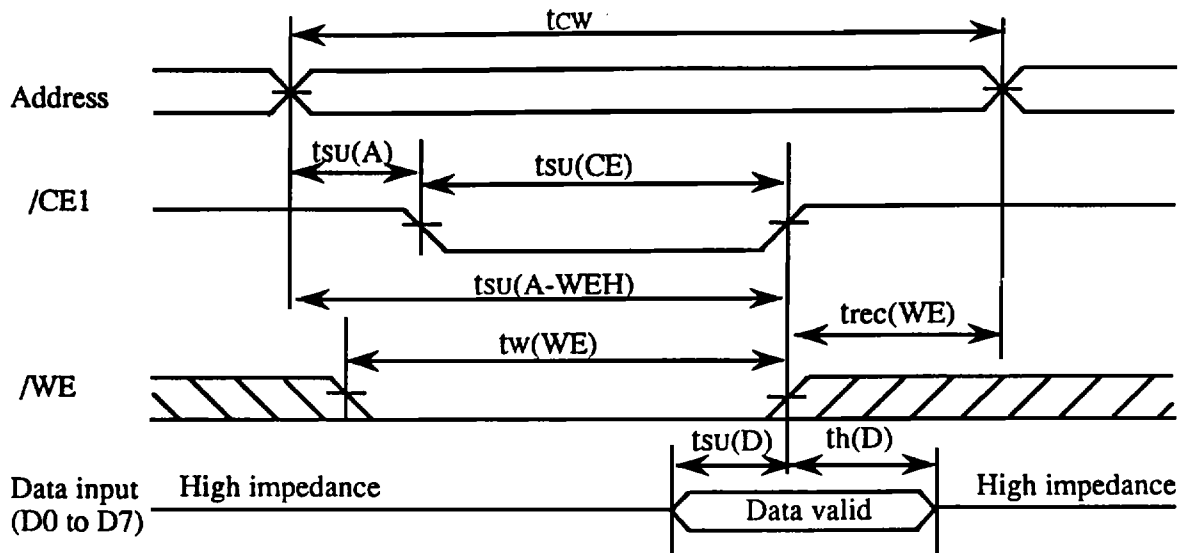

Note9)

1. Data is written when the /CE1 signal is low and /WE signal is low and overlapped ($t_{su}(CE)$).
2. When a data signal is in the output state, do not apply an input signal in a reverse phase to the output.
3. The hatched part may be either high or low.
4. To keep the output buffer of a data signal in the high impedance state, falling the /CE1 signal simultaneously with or later than falling of the /WE signal, and rising the /CE1 signal simultaneously with or earlier than rising of the /WE signal.

● Write Cycle Timing (5) (/CE1=VIH fixing) 8bits output (/CE2 control)

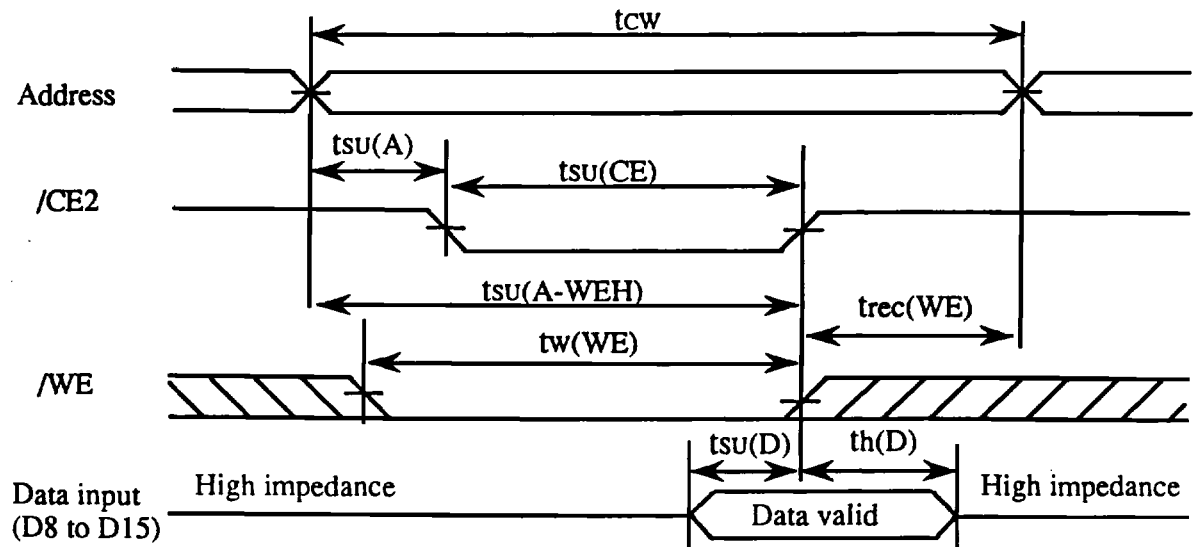

Note10)

1. Data is written when the /CE1 signal is low and /WE signal is and overlapped ($t_{su}(CE)$).
2. When a data signal is in the output state, do not apply an input signal in a reverse phase to the output.
3. The hatched part may be either high or low.
4. To keep the output buffer of a data signal in the high impedance state, falling the /CE2 signal simultaneously with or later than falling of the /WE signal, and rising the /CE2 signal simultaneously with or earlier than rising of the /WE signal.

● Write Cycle Timing (6) 16bits output (/CE1, /CE2 control)

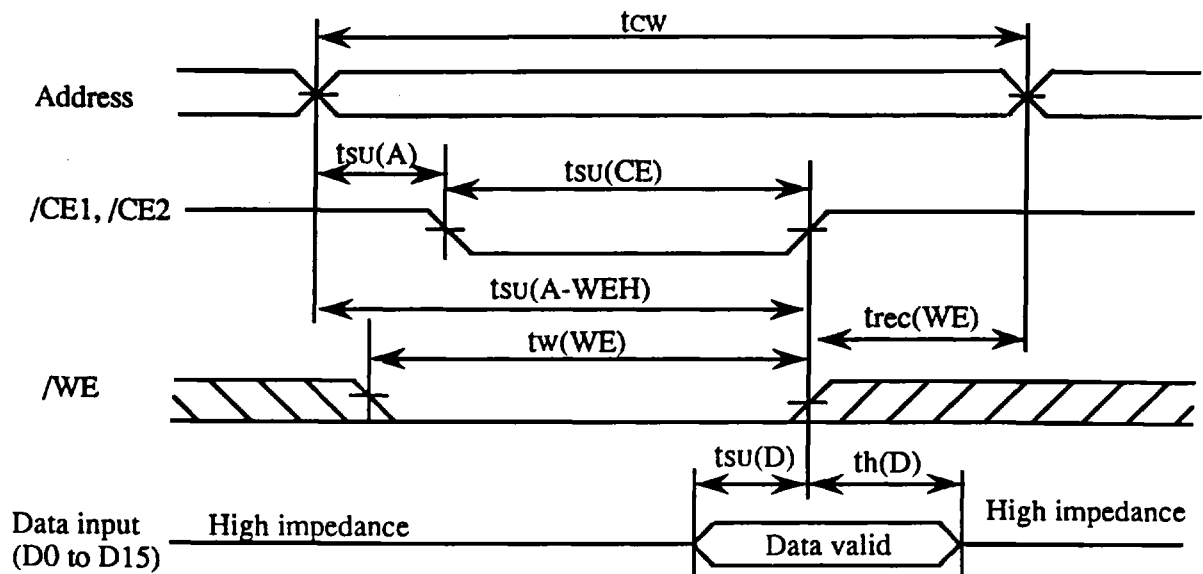

Note11)

1. Data is written when the /CE1 and /CE2 signal is low and /WE signal is low and overlapped (tsu(CE)).
2. When a data signal is in the output state, do not apply an input signal in a reverse phase to the output.
3. The hatched part may be either high or low.
4. Change the /CE1 signal and the /CE2 signal simultaneously.
5. To keep the output buffer of a data signal in the high impedance state, falling the /CE1 signal and the /CE2 signal simultaneously with or later than falling of the /WE signal, and rising the /CE1 signal and the /CE2 signal simultaneously with or earlier than rising of the /WE signal.

Power up / Power down Timing (Ta=+20°C)

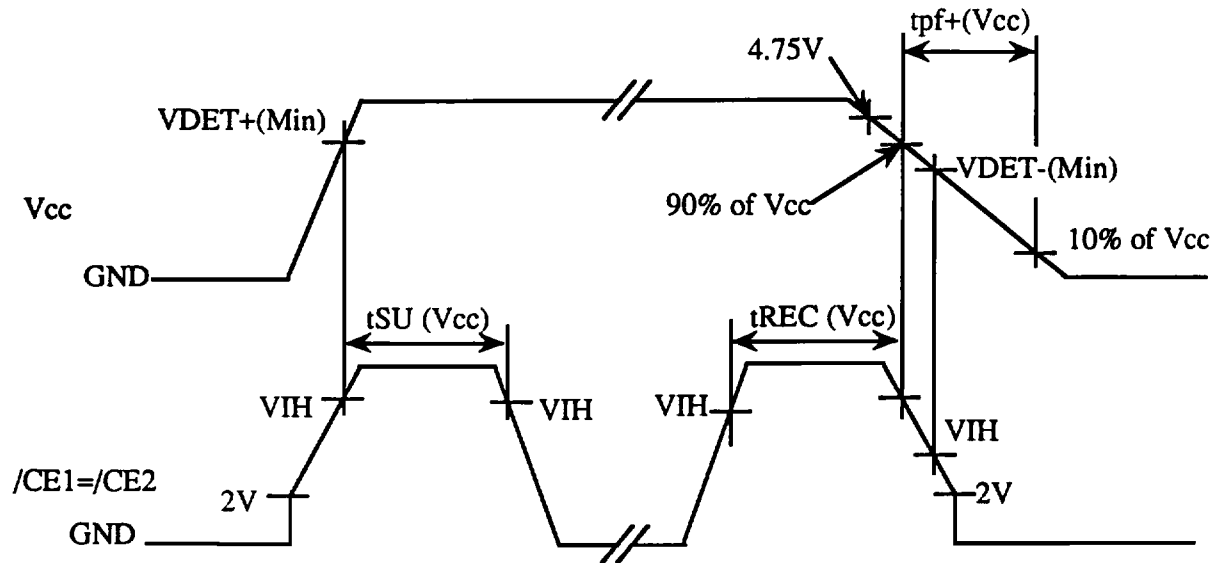

$$(0.7 \times V_{cc} \leq V_{IH} \leq V_{cc} + 0.3)$$

Symbol	Parameter	Min.	Max.	Unit
VDET+	Operation start detection voltage	4.15	4.45	V
VDET-	Operation stop detection voltage	4.05	4.35	V
VSU(CE)	/CE setup time	4.0	-	msec
tREC(CE)	/CE recover time	1.0	-	μ sec
Vpf(Vcc)	Vcc falling time	3.0	300	msec

Note12)

When inserting or removing the memory card with Vcc (5V \pm 5%) applied, keep the /CE1 and /CE2 signals in the high impedance state. Simultaneously, also keep other signals in the high impedance state. During the /CE setup time (4msec min.) after the memory card is inserted, do not access the memory card. (In this period, do not set both or one of the /CE1 and /CE2 signals low.)

■ Battery voltage detect

When the memory card is applied with V_{CC} ($5V \pm 5\%$), the voltage of the battery mounted on the memory card is outputted as a digital signal.

Period	BVD1(#63)	BVD2(#62)	Comment
1*	H	H	The battery voltage is normal.
2	H	L	In this period, exchange the battery.
3	L	L	The battery voltage is abnormal.(Data cannot be stored)

Note) 1. Exchange the battery during period 1, if possible, according to the memory retention period.



Item	Min.	Max.	Unit	Measurement conditions
V_{OL} (BVD)	0.4	—	V	$I_{OL}=5mA$
V_{OH} (BVD)	—	4.5	V	$I_{OH}=-4mA$

■ Attribute memory

The attribute memory is for storing the card attribute information. The card is not provided with attribute memory. Consequently, when address 0 is read in the same way as main memory after setting the /REG signal to the "L" level, FF(H) is output to D0-D7. The access time at this time is a maximum 300ns.

■ Write-protect switch

To protect the memory card from being written on, set the write-protect switch on the side of the memory card to PROTECT.

Write-protect switch	WP signal (pin 33)	Description
Protection mode PROTECT side 	H	Neither attribute memory nor main memory can be written on. However, both attribute memory and main memory can be read.
Non-Protection mode PROTECT side 	L	Both attribute memory and main memory can be written on and read.

Document

■ Attribute memory AC Characteristics ($T_a=0$ to $+55^\circ\text{C}$, $V_{cc}=5\text{V} \pm 5\%$)

● AC Characteristics measurement Condition

- Input pulse level : 0.8 to 3.5V
- Input pulse rise and fall time : 10 ns
- Input and output timing reference level : 1.5V
- Output load : 1TTL+CL(100pF)
(Including scope and jig capacitance)

● Attribute memory read cycle

Parameter	Symbol	Standard		Unit
		Min.	Max.	
Read cycle time	t _{CR}	300	—	ns
Address access time	t _a (A)	—	300	ns
Card enable access time	t _a (CE)	—	300	ns
Output enable time	t _a (OE)	—	150	ns
Output disable time from /CE1, /CE2	t _{dis} (CE)	—	100	ns
Output disable time from /OE	t _{dis} (OE)	—	100	ns
Output enable time from /CE1, /CE2	t _{en} (CE)	5	—	ns
Output enable time	t _{en} (OE)	5	—	ns
Data valid from address change	t _v (A)	0	—	ns

● Attribute memory read cycle waveform

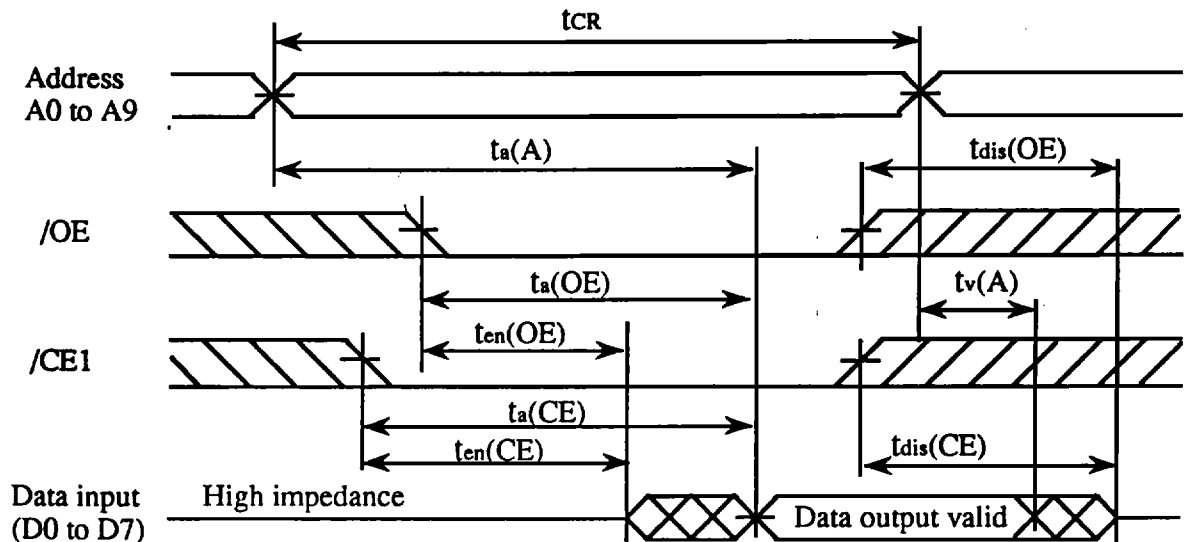

Note)

Set the /REG signal to the "L" level and the /WE signal to the "H" level when attribute memory is read, and set either the /CE2 signal to the "L" level or the /CE2 signal to the "H" level and the A0 signal to "L" level

Document

● Attribute memory write cycle

Parameter	Symbol	Standard		Unit
		Min.	Max.	
Write cycle time	t _{WC}	10	—	ms
Write pulse width	t _{WP}	180	—	ns
Address setup time	t _{SU(A)}	10	—	ns
Data setup time	t _{SU(D)}	100	—	ns
Write setup time	t _{SU(W)}	0	—	ns
Output enable setup time	t _{SU(OE)}	45	—	ns
Address retention time	t _{AH}	260	—	ns
Write retention time	t _{CH}	0	—	ns
Guard enable pulse width	t _{CW}	210	—	ns
Output enable retention time	t _{OEH}	70	—	ns
/WE high level retention time	t _{WEH}	9.9	—	ms
/CE high level retention time	t _{CEH}	9.9	—	ms
Data retention time	t _{h(D)}	80	—	ns

● Attribute memory write cycle waveform (/WE control)

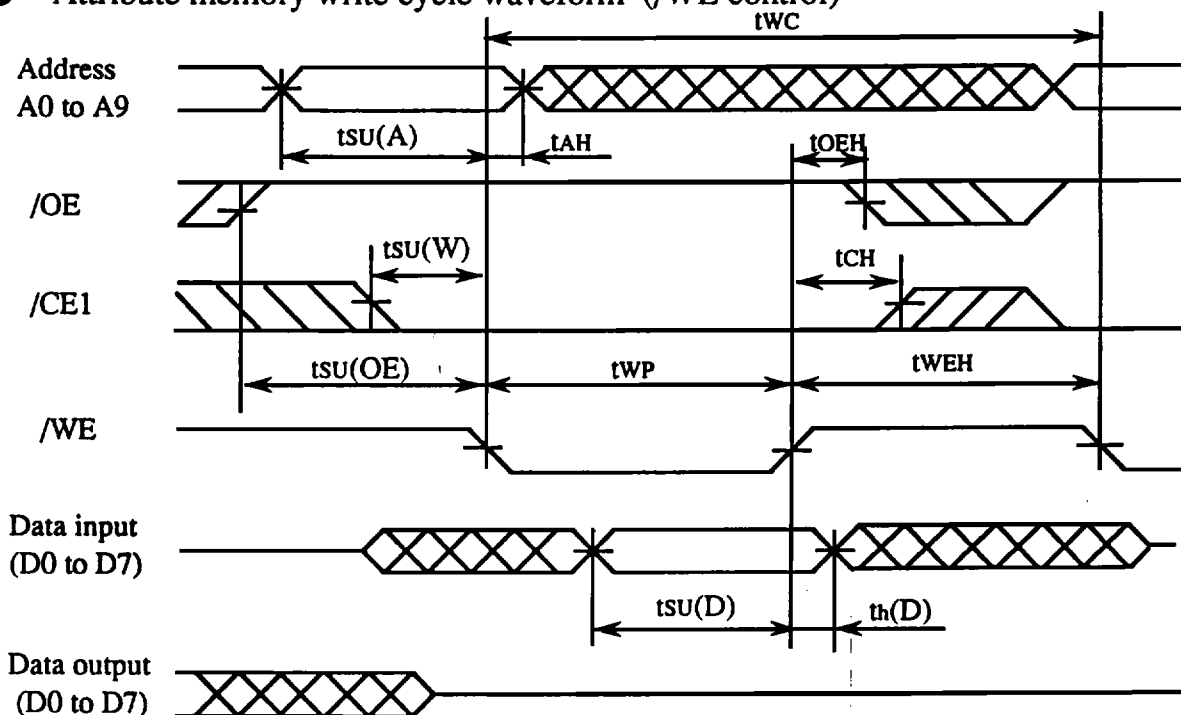

Note)

Set the /REG signal to the "L" level when attribute memory is write, and set either the /CE2 signal to the "L" level or the /CE2 signal to the "H" level and the A0 signal to the "L" level.

Document

● Attribute memory write cycle waveform (/CE control)

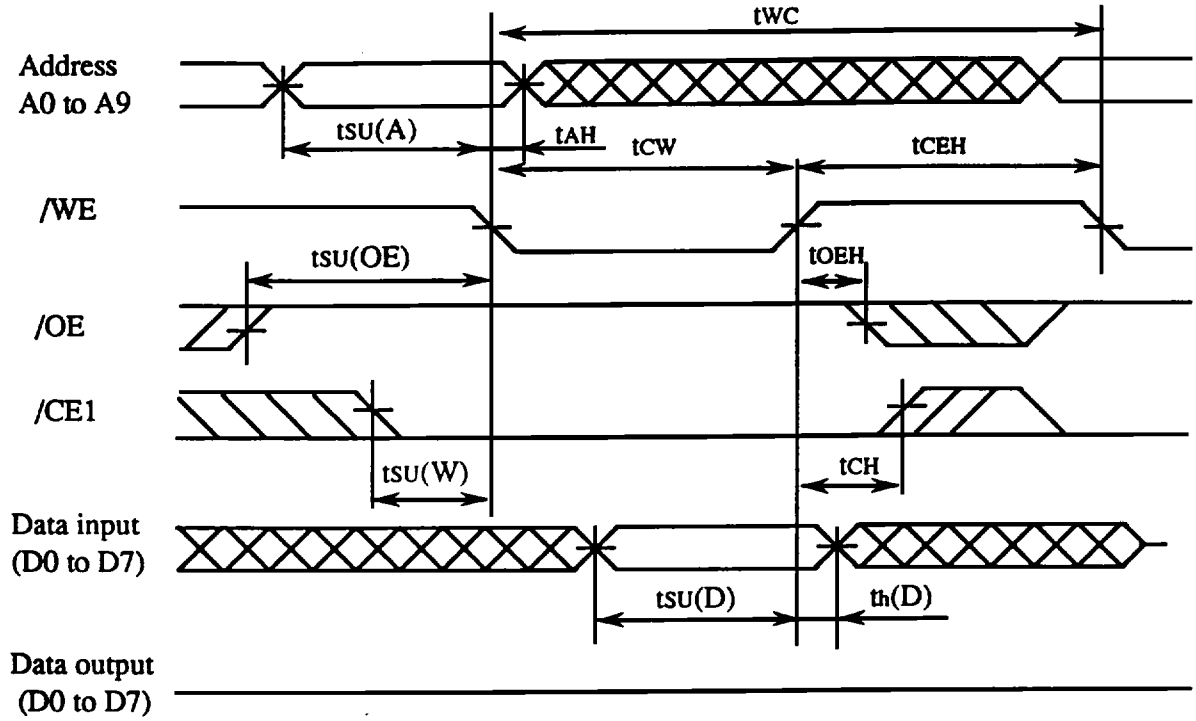

Note)

Set the /REG signal to the "L" level when attribute memory is write, and set either the /CE2 signal to the "L" level or the /CE2 signal to the "H" level and the A0 signal to the "L" level.

■ Revision Record

Revision	Date	Content Modification	Drawn by	Approved by
0	Sep.10.'92	Initial issue	<i>T. Sugano</i>	<i>K. Yamazaki</i>