

Contents

Features.....	1
Block Diagram.....	1
Operation	2
Terminal Functions.....	2
Absolute Maximum Ratings.....	2
DC Electrical Characteristics.....	3
AC Electrical Characteristics	3
Dimensions	4
Pad Coordinates (The origin of the coordinates axes is the center of the chip)	4

64-bit THERMAL HEAD DRIVER

S-4602A

The S-4602A is a CMOS thermal print head driver containing a 64-bit shift register and a latch. The 75 μm driver output pad pitch allows for high density mounting up to 300dpi. It can be used for general purpose because "H" or "L" can be selected for the latch and the driver enable .

■ Features

- Low current consumption : 0.3 mA typ.
($f_{\text{CLK}}=2$ MHz, SI : fixed)
- High speed operation : 10 MHz (cascade connection)
- Driver output voltage : 36 V max.
- Driver output current : 15 mA typ.
($V_{\text{OL}}=0.7$ V, $T_a=-10$ to 80°C)
- 64-bit shift register and latch are built in
- Driver enable
- Driver-off function when supply voltage falls
- Selectable "H/L" for latch and driver enable

■ Block Diagram

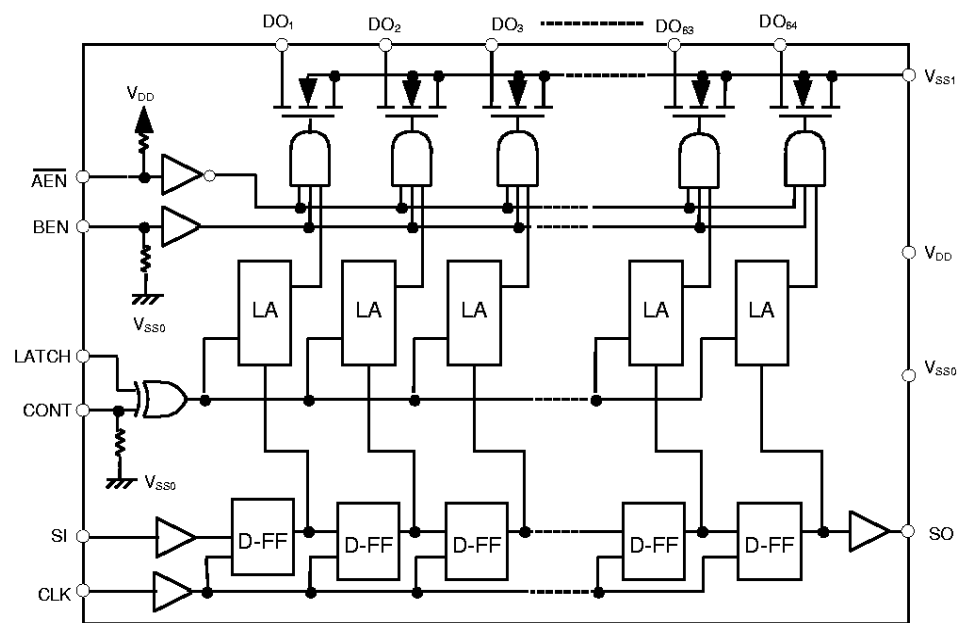

Figure 1

■ Operation

The 64-bit shift register reads the data input to SI on the rising edge of the CLOCK input.

The latch circuit operates depending on the levels of CONT and LATCH ; it reads the data of the shift register when their levels are the same, and it holds the data of the shift register when they differ.

The latch data are output to the respective drivers when $\overline{\text{AEN}}$ is low and BEN is high. The driver output transistor turns on when the latch data are high and turns off when low. Turning $\overline{\text{AEN}}$ high or BEN low makes all driver output transistors go off.

All driver output transistors go off when power supply voltage becomes lower than V_{DET} regardless of all input signals.

■ Terminal Functions (Refer to the dimensions for the pad arrangement)

Table 1

No.	Name	Functions
1 to 64	DO ₁ to DO ₆₄ (DOn)	Driver output terminals (Nch open-drain)
65, 66, 73, 74, 80, 81	V _{SS1}	GND for driver (0 V)
71, 78	V _{DD}	Positive power supply for logic (+5 V)
67, 75	V _{SS0}	GND for logic (0 V)
77	CLK	Clock input terminal for 64-bit shift register
79	SI	Serial data input terminal for 64-bit shift register
68	SO	Serial data output terminal for 64-bit shift register
69	LATCH	Data latch signal input terminal When CONT="L" or open LATCH="L": reads the data of the shift register LATCH="H": holds the preceding data When CONT="H" LATCH="L": holds the preceding data LATCH="H": reads the data of the shift register
72	CONT	Data latch signal control terminal : selects "H" or "L" for LATCH(pull-down resistor is built in)
76	$\overline{\text{AEN}}$	Driver enable terminal : outputs the latch data to the driver when "L" (pull-up resistor is built in)
70	BEN	Driver enable terminal : outputs the latch data to the driver when "H" (pull-down resistor is built in)

■ Absolute Maximum Ratings

Table 2

Parameter	Symbol	Ratings	Unit
Supply voltage	V _{SS0,1} - V _{DD}	-0.4 to +7.0	V
Driver output voltage	V _{DOH}	36	V
Driver output current	I _{DOL}	30	mA
Input voltage	V _{IN}	V _{SS0} -0.5 to V _{DD} +0.5	V
Output voltage	V _{OUT}	V _{SS0} -0.5 to V _{DD} +0.5	V
Max. junction temperature	T _{JMAX}	125	°C
Operating temperature	T _{opr}	-10 to +80	°C
Storage temperature	T _{stg}	-40 to +125	°C

■ DC Electrical Characteristics

Table 3
(Unless otherwise specified : $V_{DD}=5.0\text{ V}\pm 10\%$, $T_a=-10^\circ\text{C}$ to 80°C)

Parameter	Symbol	Conditions	Min.	Typ.	Max.	Unit	
Supply voltage	V_{DD}		4.5	5.0	5.5	V	
High level input voltage	V_{IH}		$0.8 \times V_{DD}$	—	V_{DD}	V	
Low level input voltage	V_{IL}		V_{SS}	—	$0.2 \times V_{DD}$	V	
High level input current	I_{IH}	$V_{DD}=5.0\text{ V}$ $V_{IH}=5.0\text{ V}$ $T_a=25^\circ\text{C}$	BEN, CONT	—	17	55	μA
				—	—	0.5	μA
Low level input current	I_{IL}	$V_{DD}=5.0\text{ V}$ $V_{IL}=0\text{ V}$ $T_a=25^\circ\text{C}$	$\overline{\text{AEN}}$	-55	-17	—	μA
				-0.5	—	—	μA
High level output voltage	V_{OH}	SO terminal, no load	4.45	—	—	V	
Low level output voltage	V_{OL}	SO terminal, no load	—	—	0.05	V	
High level output current	I_{OH}	SO terminal, $V_{OH}=V_{DD}-0.4\text{ V}$	—	—	-0.5	mA	
Low level output current	I_{OL}	SO terminal, $V_{OL}=0.4\text{ V}$	0.5	—	—	mA	
High level driver output voltage	V_{DOH}	Heat generator resistance : 1000Ω min	—	24	28	V	
Low level driver output voltage	V_{DOL}	$I_{DOL}=15\text{ mA}$	—	0.7	1.5	V	
Driver leakage current	I_{LEAK}	$V_{DOH}=26\text{ V}$ Per 1-bit of driver output	—	—	1.0	μA	
Current consumption	I_{DD}	$f_{CLK}=2\text{ MHz}$, $T_a=25^\circ\text{C}$ SI : fixed	—	0.3	1.0	mA	
Lower V_{DD} detection voltage	V_{DET}		0.8	—	4.0	V	

■ AC Electrical Characteristics

Table 4
($V_{DD}=5.0\text{ V}\pm 10\%$, $T_a=-10^\circ\text{C}$ to 80°C)

Parameter	Symbol	Conditions	Min.	Typ.	Max.	Unit
CLK pulse width	t_{WCLK}	$V_{IH}=V_{DD}$, $V_{IL}=V_{SS0}$ $V_{IH}=V_{DD}$, $V_{IL}=V_{SS0}$	40	—	—	ns
Data setup time	t_{SUD}		40	—	—	ns
Data hold time	t_{HD}		40	—	—	ns
Latch pulse width	t_{WLA}		50	—	—	ns
Latch setup time	t_{SULA}		50	—	—	ns
CLK-SO propagation delay time	t_{dSO}	$C_L=3\text{ pF}$	—	—	60	ns
EN-DOn propagation delay time	t_{dDO}	$R_L=3\text{ k}\Omega$, $V_{DOH}=24\text{ V}$	—	—	2.0	μs
DOn rise time	t_{rDO}	$R_L=3\text{ k}\Omega$, $V_{DOH}=24\text{ V}$	—	1.0	2.0	μs
DOn fall time	t_{fDO}	$R_L=3\text{ k}\Omega$, $V_{DOH}=24\text{ V}$	—	0.4	1.0	μs
Clock frequency	f_{CLK}	When cascade connection	—	—	10	MHz

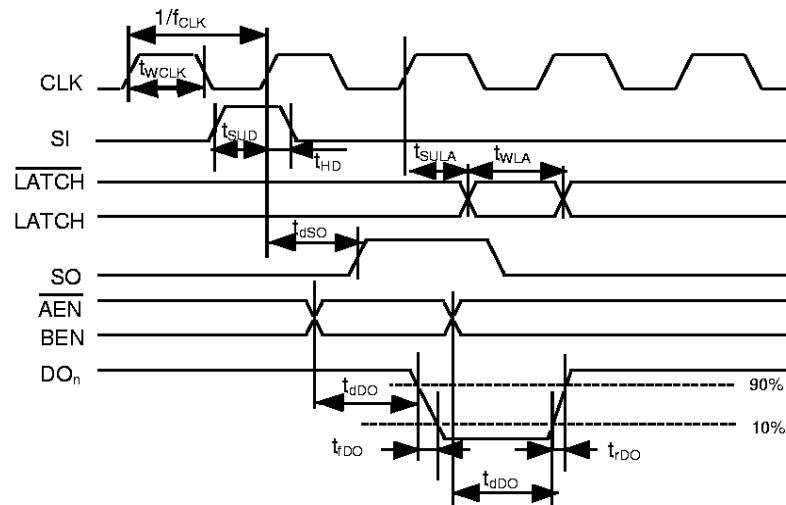

Figure 2

■ Dimensions

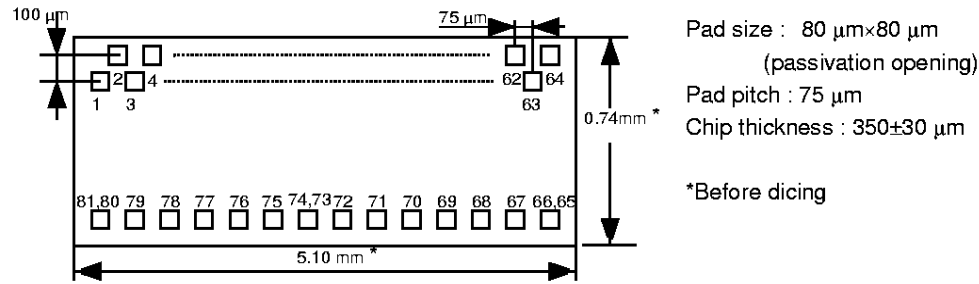

Figure 3

■ Pad Coordinates (The origin of the coordinates axes is the center of the chip)

Table 5

Unit : μm

Pad No.	Name	X	Y	Pa dN o.	Name	X	Y	Pa dN o.	Name	X	Y
1	DO ₁	-2362.5	172.5	29	DO ₂₉	-262.5	172.5	57	DO ₅₇	1837.5	172.5
2	DO ₂	-2287.5	272.5	30	DO ₃₀	-187.5	272.5	58	DO ₅₈	1912.5	272.5
3	DO ₃	-2212.5	172.5	31	DO ₃₁	-112.5	172.5	59	DO ₅₉	1987.5	172.5
4	DO ₄	-2137.5	272.5	32	DO ₃₂	-37.5	272.5	60	DO ₆₀	2062.5	272.5
5	DO ₅	-2062.5	172.5	33	DO ₃₃	37.5	172.5	61	DO ₆₁	2137.5	172.5
6	DO ₆	-1987.5	272.5	34	DO ₃₄	112.5	272.5	62	DO ₆₂	2212.5	272.5
7	DO ₇	-1912.5	172.5	35	DO ₃₅	187.5	172.5	63	DO ₆₃	2287.5	172.5
8	DO ₈	-1837.5	272.5	36	DO ₃₆	262.5	272.5	64	DO ₆₄	2362.5	272.5
9	DO ₉	-1762.5	172.5	37	DO ₃₇	337.5	172.5	65	V _{SS1}	2395.0	-272.5
10	DO ₁₀	-1687.5	272.5	38	DO ₃₈	412.5	272.5	66	V _{SS1}	2275.0	-272.5
11	DO ₁₁	-1612.5	172.5	39	DO ₃₉	487.5	172.5	67	V _{SS0}	2060.0	-272.5
12	DO ₁₂	-1537.5	272.5	40	DO ₄₀	562.5	272.5	68	SO	1795.0	-272.5
13	DO ₁₃	-1462.5	172.5	41	DO ₄₁	637.5	172.5	69	LATCH	1200.0	-272.5
14	DO ₁₄	-1387.5	272.5	42	DO ₄₂	712.5	272.5	70	BEN	935.0	-272.5
15	DO ₁₅	-1312.5	172.5	43	DO ₄₃	787.5	172.5	71	V _{DD}	600.0	-272.5
16	DO ₁₆	-1237.5	272.5	44	DO ₄₄	862.5	272.5	72	CONT	320.0	-272.5
17	DO ₁₇	-1162.5	172.5	45	DO ₄₅	937.5	172.5	73	V _{SS1}	55.0	-252.5
18	DO ₁₈	-1087.5	272.5	46	DO ₄₆	1012.5	272.5	74	V _{SS1}	-65.0	-252.5
19	DO ₁₉	-1012.5	172.5	47	DO ₄₇	1087.5	172.5	75	V _{SS0}	-285.0	-272.5
20	DO ₂₀	-937.5	272.5	48	DO ₄₈	1162.5	272.5	76	$\overline{\text{AEN}}$	-550.0	-252.5
21	DO ₂₁	-862.5	172.5	49	DO ₄₉	1237.5	172.5	77	CLK	-990.0	-252.5
22	DO ₂₂	-787.5	272.5	50	DO ₅₀	1312.5	272.5	78	V _{DD}	-1740.0	-252.5
23	DO ₂₃	-712.5	172.5	51	DO ₅₁	1387.5	172.5	79	SI	-2005.0	-252.5
24	DO ₂₄	-637.5	272.5	52	DO ₅₂	1462.5	272.5	80	V _{SS1}	-2275.0	-252.5
25	DO ₂₅	-562.5	172.5	53	DO ₅₃	1537.5	172.5	81	V _{SS1}	-2395.0	-252.5
26	DO ₂₆	-487.5	272.5	54	DO ₅₄	1612.5	272.5				
27	DO ₂₇	-412.5	172.5	55	DO ₅₅	1687.5	172.5				
28	DO ₂₈	-337.5	272.5	56	DO ₅₆	1762.5	272.5				