



Dear customers,

About the change in the name such as "Oki Electric Industry Co. Ltd." and "OKI" in documents to OKI Semiconductor Co., Ltd.

The semiconductor business of Oki Electric Industry Co., Ltd. was succeeded to OKI Semiconductor Co., Ltd. on October 1, 2008. Therefore, please accept that although the terms and marks of "Oki Electric Industry Co., Ltd.", "Oki Electric", and "OKI" remain in the documents, they all have been changed to "OKI Semiconductor Co., Ltd.". It is a change of the company name, the company trademark, and the logo, etc. , and NOT a content change in documents.

October 1, 2008
OKI Semiconductor Co., Ltd.

OKI SEMICONDUCTOR CO., LTD.

550-1 Higashiasakawa-cho, Hachioji-shi, Tokyo 193-8550, Japan
<http://www.okisemi.com/en/>

MSM9831-xxx**VOICE SYNTHESIS LSI with on-chip 384Kbit MASK ROM****GENERAL DESCRIPTION**

MSM9831 is a PCM-based Voice Synthesis LSI (Playback only) with on-chip 384 Kbit Mask ROM, D/A Converter and Low-Pass Filter.

Serial input interface for an external MCU makes MSM9831 a better choice for size-critical applications with less wiring pin-count in small foot-print packaging.

FEATURES

- 8-bit OKI Non-Linear PCM Algorithm
- Sampling Frequency (Selectable on each phrase)
4.0/5.3/6.4/8.0/10.6/12.8/16.0 kHz
- On-chip Mask ROM Capacity : 384 Kbits
- Maximum Playback Time Length
12.0 sec. at fsam = 4.0 kHz
6.0 sec. at fsam = 8.0 kHz
3.0 sec. at fsam = 16.0 kHz
- Clock Oscillation
3.5 to 4.5 MHz (Ceramic Oscillation)
3.5 to 17 MHz (External Clock)
- User definable Phrase Control Table function
- Maximum number of Phrases : 31 phrases
- 10-bit current-output-type D/A Converter
- A built-in LPF
- Power Supply Voltage : +2.0 to +5.5 V (External Clock)
+2.5 to +5.5 V (Ceramic Oscillation)
- Package:
8-Pin SOP Package (SOP8-P-250-1.27-K) (Product name: MSM9831-xxx MA)

COMPARISON TABLE WITH MSM9802

	MSM9831	MSM9802
Mask ROM Capacity	384K Bit	512K Bit
Interface	MCU (Serial)	MCU (Parallel)/Stand-alone
Oscillation	Ceramic/External Clock	Ceramic/CR
Max. Phrase Number	31	63
Status Signal	None	NAR/BUSY
D/A Converter Current Flowing	Forced into the circuit	Forced out of the circuit

PIN CONFIGURATION (TOP VIEW)

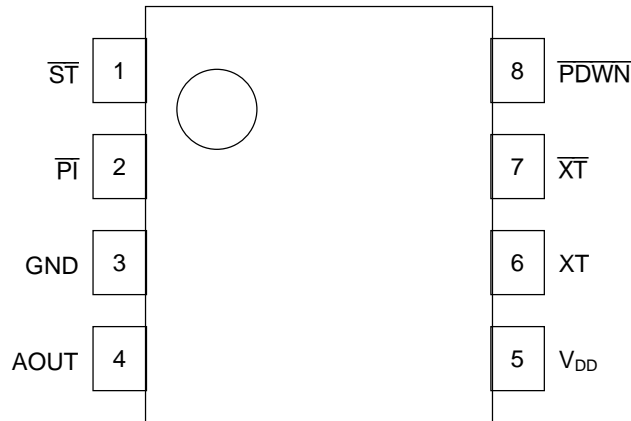

8-pin Plastic SOP

BLOCK DIAGRAM

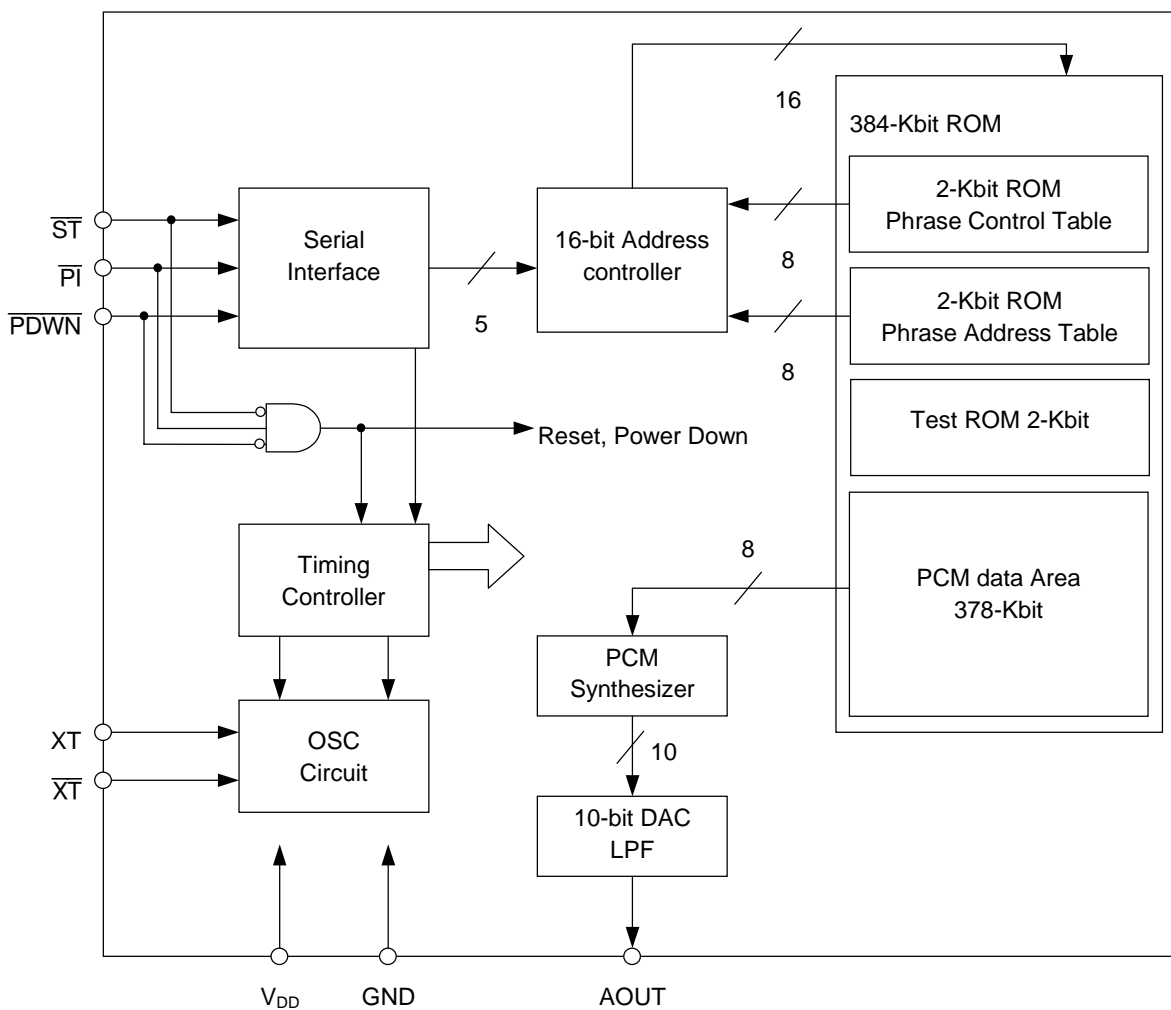

PIN DESCRIPTIONS

Pin	Symbol	I/O	Description
1	\overline{ST}	I	Playback starter pin. Phrase Address (number) is determined by the number of times of input to \overline{PI} pin while \overline{ST} being held "L". Playback starts on \overline{ST} 's rising edge with phrase address data loaded into the LSI. When no pulse input to \overline{PI} made while \overline{ST} being held "L", the LSI recognizes it as "Stop Code" to stop playback.
2	\overline{PI}	I	Address input pin. The phrase number to playback is determined by the times of pulse input to \overline{PI} pin while \overline{ST} being held "L". 32-time pulse input has the internal counter initialized.
3	GND	—	GND pin.
4	AOUT	O	Analog output pin. Built with N-MOS open-drain type, wave-form output is made in the form of changing output current. While \overline{PDWN} being held "H", AOUT maintains 1/2 level output, thus the current keeps on flowing. The Pop-Noise Canceller is put into works when standby is reset to return to be active, and when entering into standby mode.
5	V_{DD}	—	Power supply pin. Insert a 0.1 μ F or larger by-pass capacitor in-between GND pin and this pin.
6	XT	I	Wired to the ceramic oscillator when a ceramic oscillator is in use. Input the clock signal to this pin when the external clock is selected as the timing source. Using a ceramic oscillator or an external clock can be selected with OKI's Analyzing and Editing Tool.
7	\overline{XT}	O	Wired to the ceramic oscillator when a ceramic oscillator is in use. When the external clock is in use, keep this pin open.
8	\overline{PDWN}	I	The LSI remains in standby mode while this pin is being held "L".

ABSOLUTE MAXIMUM RATINGS

(GND = 0 V)

Parameter	Symbol	Condition	Rating	Unit
Power Supply Voltage	V_{DD}	$T_a = 25^\circ\text{C}$	-0.3 to +7.0	V
Input Voltage	V_{IN}		-0.3 to $V_{DD}+0.3$	V
Storage Temperature	T_{STG}	—	-55 to +150	$^\circ\text{C}$

RECOMMENDED OPERATING CONDITIONS

(GND = 0 V)

Parameter	Symbol	Condition	Range			Unit
Power Supply Voltage	V_{DD}	With a Ceramic Osc. (Note)	2.5 to 5.5			V
		With the external clock $f_{OSC} = 3.5$ to 4.5 MHz	2.0 to 5.5			V
		With the external clock $f_{OSC} = 3.5$ to 14.5 MHz	2.7 to 5.5			V
		With the external clock $f_{OSC} = 3.5$ to 17 MHz	3.0 to 5.5			V
Master Clock Frequency	f_{OSC}		Min.	Typ.	Max.	
		With a Ceramic Osc. $V_{DD} = 2.0$ to 5.5 V (Note)	3.5	4.096	4.5	MHz
		With the external clock $V_{DD} = 2.5$ to 5.5 V	3.5	4.096	4.5	MHz
		With the external clock $V_{DD} = 2.7$ to 5.5 V	3.5	—	14.5	MHz
		With the external clock $V_{DD} = 3.0$ to 5.5 V	3.5	—	17	MHz
Operating Temperature	T_{op}	—	-40 to +85			$^\circ\text{C}$

Note: A crystal that is usable in this LSI is described in "Functional Description" of this document. If you want to use a different crystal, it is recommended to evaluate the crystal before using it.

ELECTRICAL CHARACTERISTICS

DC Characteristics

(V_{DD} = 2.0 to 5.0 V, GND = 0 V, f_{OSC} = 4.096 MHz, Ta = -40 to +85°C, unless otherwise specified)

Parameter	Symbol	Condition	Min.	Typ.	Max.	Unit	
"H" Input Voltage	V _{IH}	f _{OSC} = 14.5 MHz or less (V _{DD} = 2.7 to 5.5 V)	V _{DD} × 0.8	—	—	V	
		f _{OSC} = 4.5 MHz or less (V _{DD} = 2.0 to 5.5 V)					
		f _{OSC} > 14.5 MHz (V _{DD} = 3.0 to 5.5 V)	V _{DD} × 0.85	—	—	V	
"L" Input Voltage	V _{IL}	f _{OSC} = 14.5 MHz or less (V _{DD} = 2.7 to 5.5 V)	—	—	V _{DD} × 0.2	V	
		f _{OSC} = 4.5 MHz or less (V _{DD} = 2.0 to 5.5 V)					
		f _{OSC} > 14.5 MHz (V _{DD} = 3.0 to 5.5 V)	—	—	V _{DD} × 0.15	V	
"H" Input Current	I _{IH}	V _{IH} = V _{DD}	—	—	10	μA	
"L" Input Current	I _{IL}	V _{IL} = GND	-10	—	—	μA	
Dynamic Supply Current	I _{DD}	AOUT output current is excluded	V _{DD} = 5.5 V f _{OSC} = 4.096 MHz	—	1.2	3.0	mA
			V _{DD} = 3.0 V f _{OSC} = 4.096 MHz	—	0.4	1.0	mA
			V _{DD} = 2.0 V f _{OSC} = 4.096 MHz	—	0.2	0.7	mA
			V _{DD} = 5.5 V f _{OSC} = 16 MHz	—	—	12.0	mA
			V _{DD} = 3.0 V f _{OSC} = 16 MHz	—	—	4.0	mA
			V _{DD} = 2.0 V f _{OSC} = 16 MHz	—	—	2.8	mA
Standby Supply Current	I _{DS}	Ta = -40°C to +70°C	—	—	10	μA	
		Ta = -40°C to +85°C	—	—	50	μA	
AOUT Output Current	I _{AOUT}	At maximum output current	V _{DD} = 2.0 to 5.5 V	0.4	—	8.9	mA
			V _{DD} = 5.5 V	3.8	6.0	8.9	mA
			V _{DD} = 2.0 V	0.4	1.0	1.9	mA

AC Characteristics

(Oscillation Frequency at $f_{OSC} = 4.096$ MHz, $V_{DD} = 2.0$ to 5.0 V, $GND = 0$ V, $T_a = -40$ to $+85^\circ\text{C}$)

Parameter	Symbol	Condition	Min.	Typ.	Max.	Unit
Master Clock duty cycle	f_{duty}	—	40	50	60	%
Time before RESET input after Power On	t_{RST}	—	10	—	—	μs
$\overline{\text{PDWN}}$ hold time after RESET input	t_{PDH}	—	10	—	—	μs
DA Converter shifting time (Pop-Noise Canceller working time) *1	t_{DAR}, t_{DAF}	—	60	64	68	ms
$\overline{\text{PDWN}}\text{-}\overline{\text{ST}}$ setup time	t_{PDSS}	—	1	—	—	μs
$\overline{\text{ST}}\text{-}\overline{\text{PI}}$ setup time	t_{SPS}	—	1	—	—	μs
$\overline{\text{PI}}$ pulse width	t_{PW}	—	0.35	—	2000	μs
$\overline{\text{PI}}$ cycle time	t_{PC}	—	0.7	—	4000	μs
$\overline{\text{ST}}\text{-}\overline{\text{PI}}$ hold time	t_{SPH}	—	1	—	—	μs
$\overline{\text{ST}}\text{-AOUT}$ setup time *2	t_{SAS}	$f_{SAM} = 8.0$ kHz	—	—	1050	μs
Phrase stop time *2	t_{DPS}	$f_{SAM} = 8.0$ kHz	—	—	700	μs
Silence in-between phrases *2	t_{BLN}	$f_{SAM} = 8.0$ kHz	—	—	700	μs
Stop $\overline{\text{ST}}$ pulse width	t_{SSW}	—	0.35	—	2000	μs
Phrase $\overline{\text{ST}}$ -Phrase $\overline{\text{ST}}$ pulse interval *2	t_{PP}	$f_{SAM} = 8.0$ kHz	1050	—	—	μs
Phrase $\overline{\text{ST}}$ -Stop $\overline{\text{ST}}$ pulse interval *2	t_{PS}	$f_{SAM} = 8.0$ kHz	1050	—	—	μs
Stop $\overline{\text{ST}}$ -Phrase $\overline{\text{ST}}$ pulse interval *2	t_{SP}	$f_{SAM} = 8.0$ kHz	500	—	—	μs
Sampling Frequency *3	f_{SAM}	—	3.9	—	28.0	kHz

*1 Proportional to the period of oscillation frequency (f_{OSC}).*2 Proportional to the period of sampling frequency (f_{SAM}).*3 The sampling frequency (f_{SAM}) is determined by the oscillation frequency (f_{OSC}) and the frequency dividing ratio selected for each phrase.

TIMING DIAGRAMS

Power-On

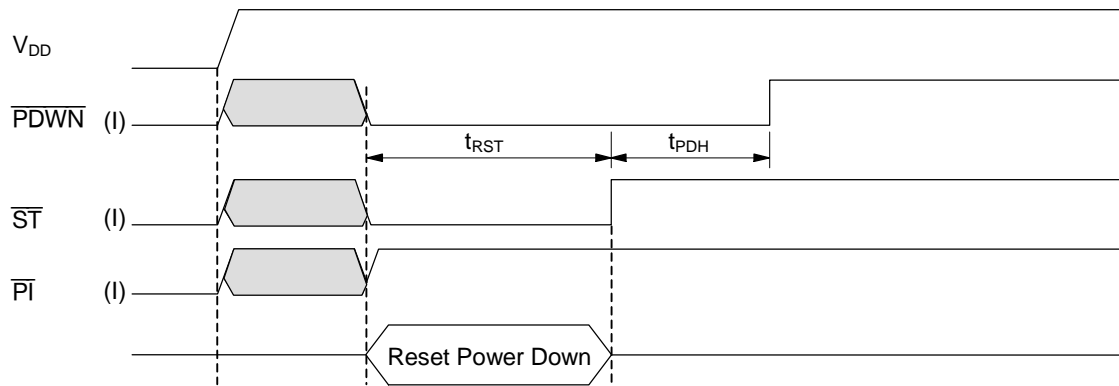

Note: A level input in combination of \overline{PDWN} ="L", \overline{ST} ="L" and \overline{PI} ="H" resets the LSI. After Power-On, you need to do an initial reset as shown in the above chart.

Activating the LSI and Standby Mode

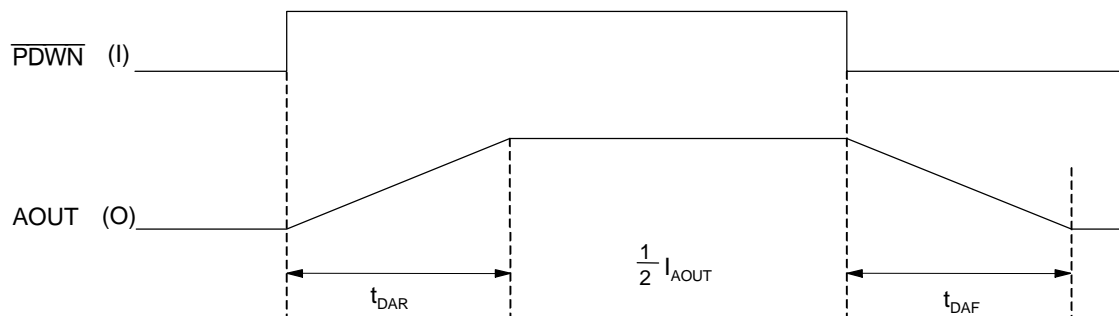

Playback

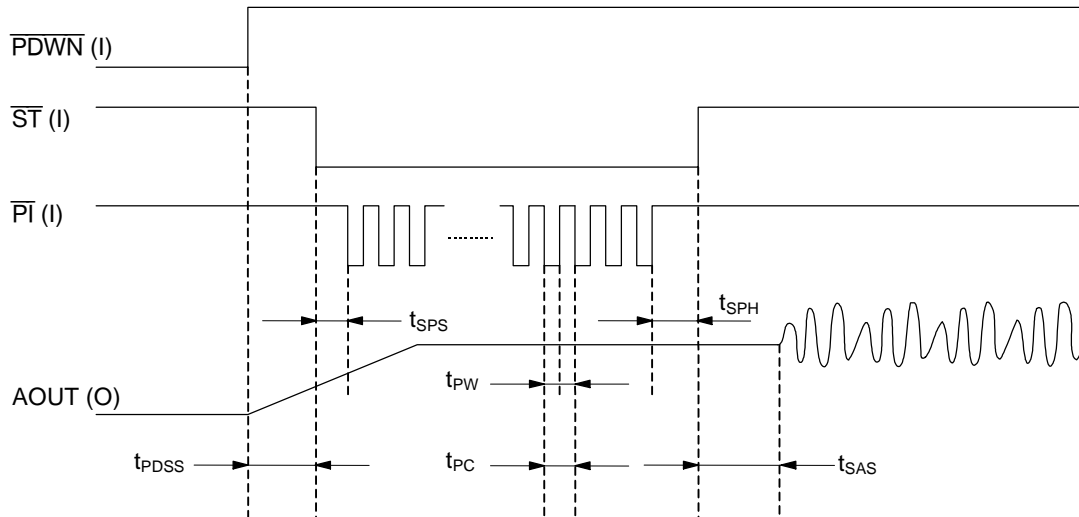

Re-inputting the address while playback is going on

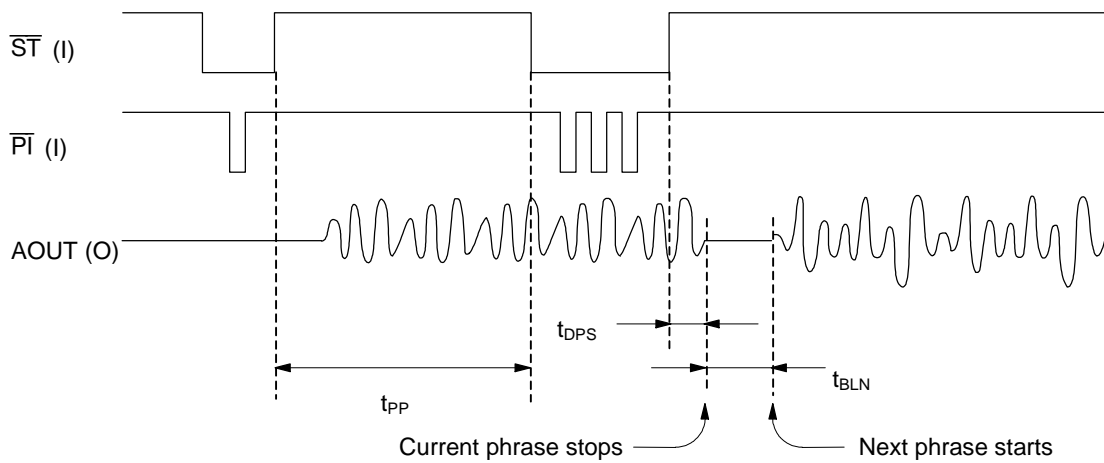

Stop Code Input

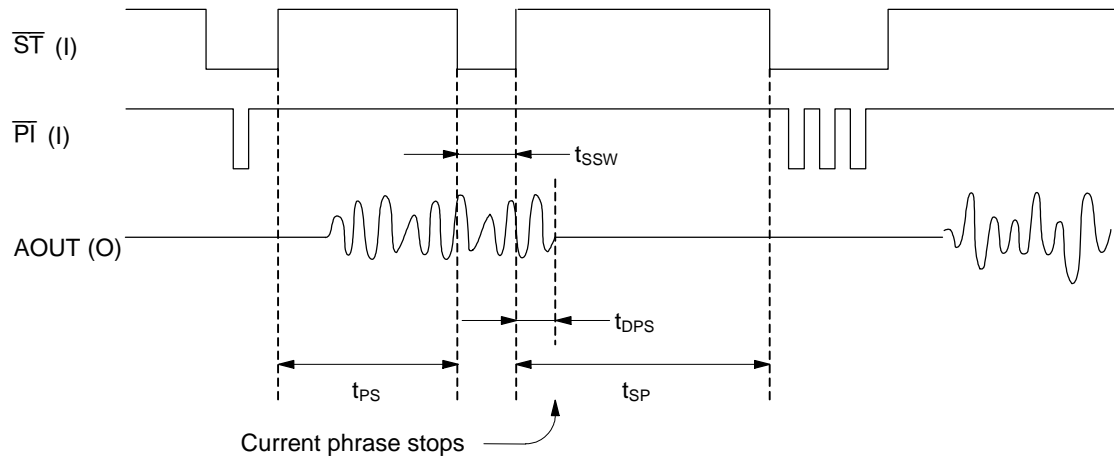

FUNCTIONAL DESCRIPTION

Sampling Frequency

Sampling Frequency can be selected and setup on each phrase address. 7 sampling frequencies are available for user's choice in preparing Voice Data File at the pre-production stage. Select sampling frequencies to satisfy $f_{SAM} = 3.9$ to 28.0 kHz obtained by frequency dividing ratios in Table 1.

Table 1 Sampling Frequency

Sampling Frequency ($f_{OSC}=4.096$ MHz)	Frequency diving ratio
4.0 kHz	$f_{OSC}/1024$
5.3 kHz	$f_{OSC}/768$
6.4 kHz	$f_{OSC}/640$
8.0 kHz	$f_{OSC}/512$
10.6 kHz	$f_{OSC}/384$
12.8 kHz	$f_{OSC}/320$
16.0 kHz	$f_{OSC}/256$

Recording/Playback Time

Figure 1 below shows memory allocation of on-chip 384K bit Mask ROM. The Mask ROM is partitioned into 4 data areas: user's Area, Phrase Control Table Area, Phrase Control Area and Test Data Area. Actual memory space is the total Mask ROM capacity (384K bit) indicated in this document minus 6K bit.

Phrase Control Table Area	2K bit
Phrase Data Control Area	2K bit
Test Data Area	2K bit
User's Area	378K bit

Figure 1 Memory Allocation of on-chip Mask ROM (384K bit)

The playback time is obtained by dividing the memory capacity by the bit rate.
The playback time for 8-bit PCM algorithm is obtained by using the following equation.

$$\text{Playback time [sec]} = \frac{\text{Memory capacity [bit]}}{\text{Bit rate [bps]}} = \frac{\text{Memory capacity [bit]}}{\text{Sampling frequency [Hz]} \times 8 \text{ [bit]}}$$

For example, if all phrases are stored in the MSM9802 at 8 kHz sampling frequency, the maximum playback time is as follows.

$$\text{Playback time} = \frac{(384-6) \times 1024 \text{ [bit]}}{8000 \text{ [Hz]} \times 8 \text{ [bit]}} \cong 6.0 \text{ [sec]}$$

Playback Method

The MSM9831 uses OKI non-linear PCM algorithm.

In the mid-range of waveform, OKI 8-bit non-linear PCM has precision equivalent to that of 10-bit straight PCM.

Inserting Silence

In addition to normal recorded sound phrases, the MSM9831 allows a user to play back or insert silence (silent phrase). User can set up time length of silence from a minimum of 32ms to a maximum of 996ms in 32ms step when $f_{\text{osc}}=4.096 \text{ MHz}$. These time lengths are directly proportioned to the clock (f_{osc}) period.

Phrase Control Table

Because the LSI contains the Phrase Control Table, it is possible to play back multiple phrases in succession by a single easy control operation like controlling a single regular phrase playback. Up to 8 combined phrases including a silence can be registered in a single address in the Phrase Control Table.

Further, you can use the maximum memory space for data storage because it is not required to have the same phrase data.

To show an example, let's assume that your application needs to speak two similar sentences, "It is fine today" and "It is rainy today." The two sentences have the common words "it", "is" and "today". What you have to do is to prepare these common sound data, not in sentences but in words, and to store each combined phrase data in Phrase Control Table as shown in Table 2 and Figure 2.

Multiple phrases can be played continuously merely by specifying a desired phrase using an X address. For an example from Table 2, when address "01" is specified, "It is fine today" is played, and when address "02" is specified, "It is rainy" is played.

Phrase Control Table, a silence can be inserted without using the User's Area.

Minimum time for silence	32 ms
Maximum time for silence	992 ms
Time unit for setting up silence	32 ms

Table 2 Matrix of the Phrase Control Table

No.	X-Address (HEX)	Y-Address (Up to 8 phrases)								Sound Data
		[01]	[02]	[03]	[04]	[05]	[06]	[07]	[08]	
1	01	[01]	[02]	Silence	[04]	[03]				It is (silence) fine today.
2	02	[01]	[02]	Silence	[05]	[03]				It is (silence) rainy today.
3	03	[01]	[02]	[04]	[09]	[06]	[05]	[0A]	[03]	It is fine becoming cloudy, rainy in some areas today.
⋮	⋮									⋮
30	1E									
31	1F									

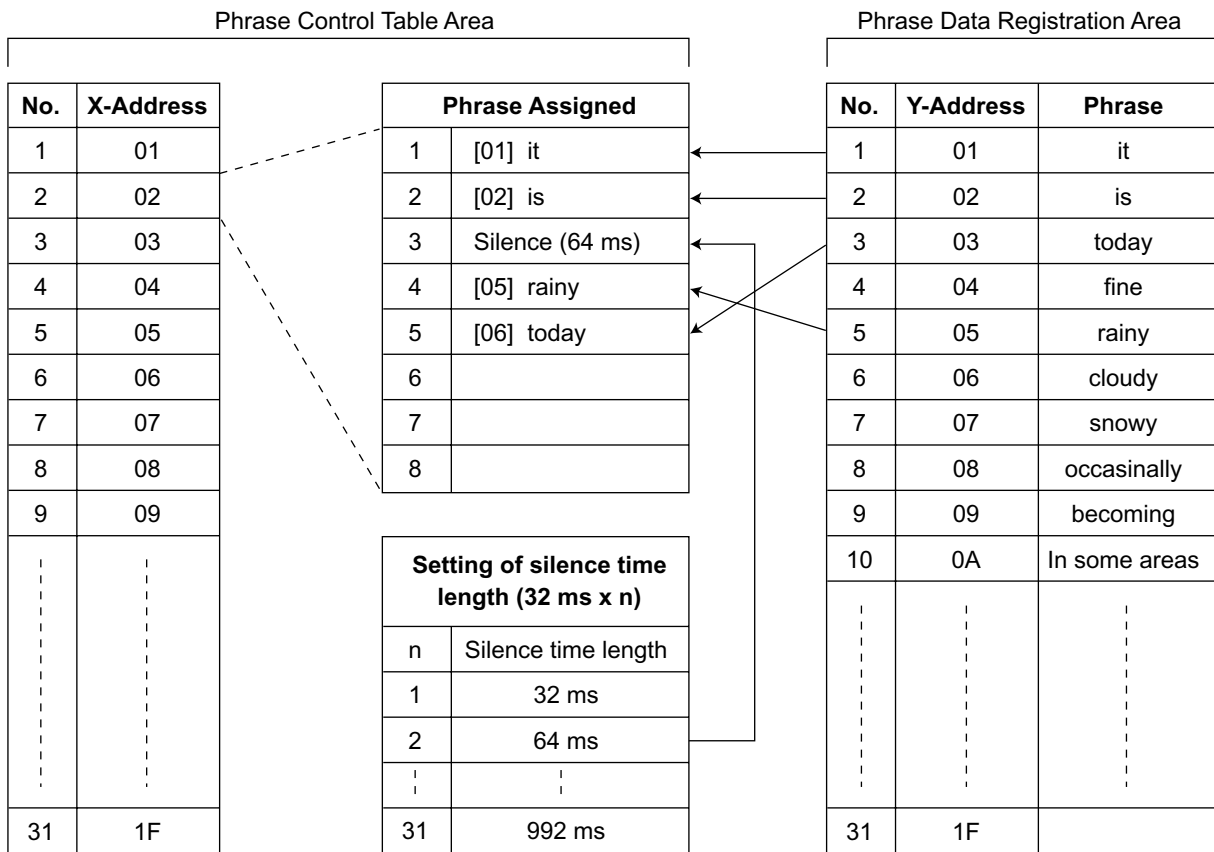

The silence time lengths are directly proportional to the clock (f_{osc}) period.

Figure 2 Phrase Combination Matrix for Phrase Control Table

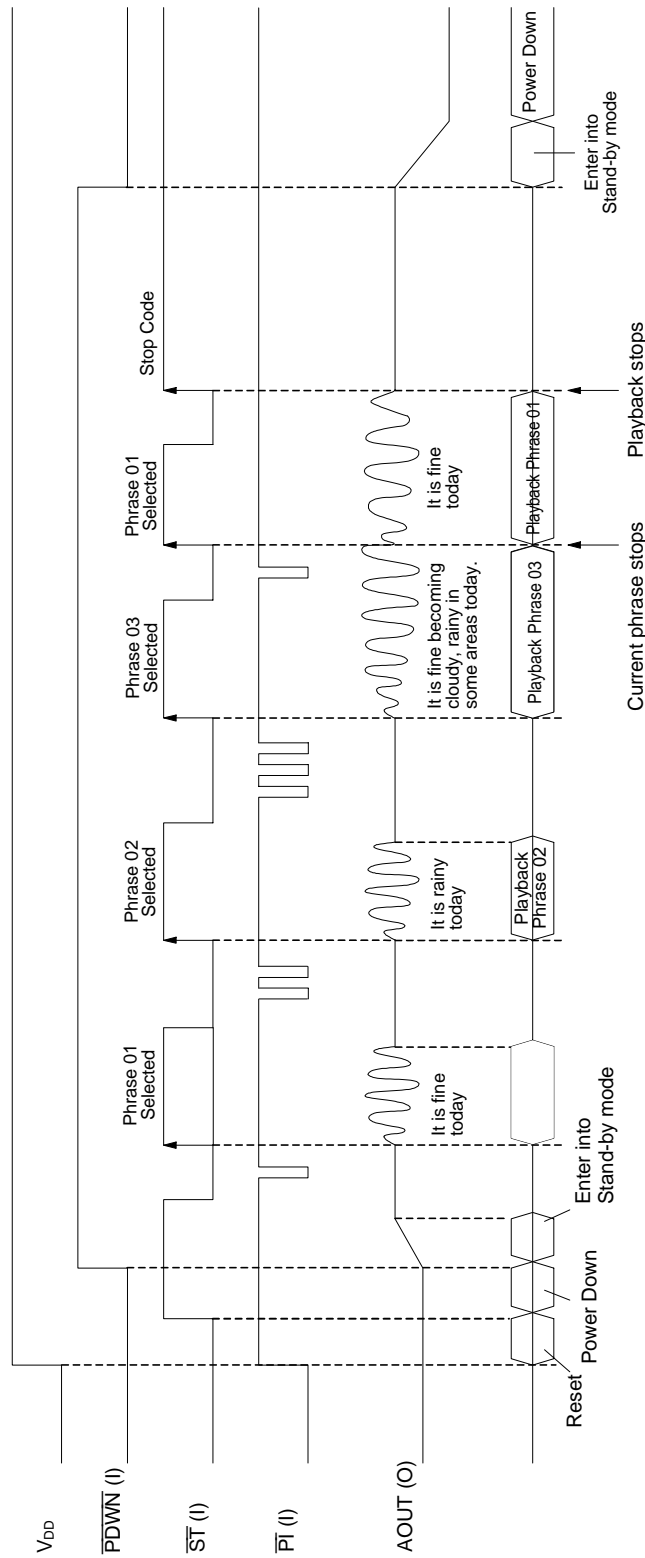

Figure 3 Playback timing when using phrase control data

Oscillation, Clock Signal Input

Using a Ceramic Oscillator

Figure 4 shows an oscillation circuit diagram using a Ceramic Oscillator.
(Select Use a Ceramic Oscillator option on selecting options)

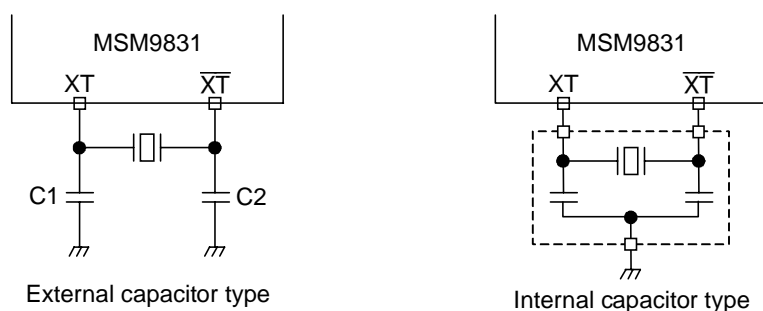

Figure 4 Oscillation Circuit with an external ceramic oscillator

The optimal load capacities when connecting ceramic oscillators from MURATA MFG., KYOCERA CORPORATION, and TDK CORPORATION are shown below for reference.

Ceramic oscillator			Optimal load capacity		Supply Voltage Range (V)	Operating Temperature Range (°C)
Maker	Type	Freq (MHz)	C ₁ (pF)	C ₂ (pF)		
MURATA MFG.	CSTCR4M09G53-R0	4.096	Built in	Built in	2.0 to 5.5	-40 to +85
	CSTLS4M09G53-B0		Built in	Built in		
TDK CORPORATION	FCR4.0M5	4.0	33	33	2.5 to 5.5	-40 to +85
	FCR4.0MC5		Built in	Built in	2.5 to 5.5	
	CCR4.0MC3					
KYOCERA CORPORATION	KBR-4.0MSA	4.0	33	33	2.5 to 5.5	-20 to +80
	KBR-4.0MSB		Built in	Built in		
	KBR-4.0MKC					
	KBR-4.0MKD					
	KBR-4.0MKS		33	33		
	PBRC4.00A		Built in	Built in		
PBRC4.00B	33	33				

Using External Clock Input

Figure 5 shows an oscillation circuit diagram using an external clock input.

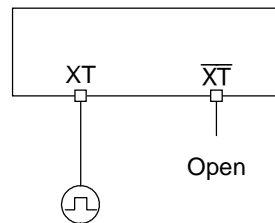

External Clock, etc. as the timing source

Figure 5 Oscillation Circuit using an external clock input

Low-Pass Filter

In this IC, all voice outputs are through the built-in low-pass filter (LPF). Figure 6 and Table 3 show the LPF frequency characteristics and LPF cutoff frequency respectively.

The frequency characteristics and cutoff frequencies are directly proportional to sampling frequencies. Only the voice output through LPF in this IC is enabled.

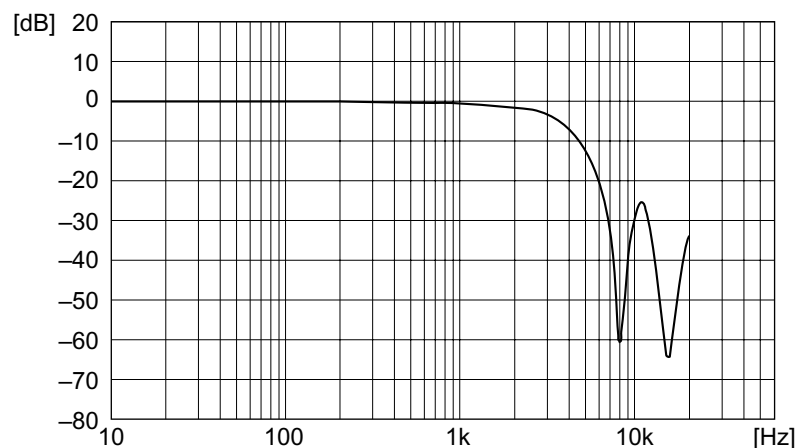

Figure 6 LPF Frequency Characteristics ($f_{SAM}=8$ kHz)

Table 3 LPF Cutoff Frequency

Sampling Frequency (kHz) (f_{SAM})	Cutoff Frequency (kHz) (f_{CUT})
4.0	1.2
5.3	1.6
6.4	2.0
8.0	2.5
10.6	3.2
12.8	4.0
16.0	5.0

CONNECTING THE MSM9831 TO SPEAKER DRIVING AMPLIFIER

The MSM9831 uses a current output type D/A converter.

When the MSM9831 is connected to a voltage input type amplifier, it is required to convert the voice signal that is output as "change of current" into the voice signal that is output as "change of voltage".

The connection between the MSM9831 and MSC1157 (OKI speaker driving amplifier) when a resistor is used for the above conversion is described below.

CIRCUIT CONNECTION EXAMPLE 1: WHEN $V_{DD} = 5.0V$ AND THE AMPLITUDE OF AIN OF THE MSC1157 IS $2.5V_{P-P}$

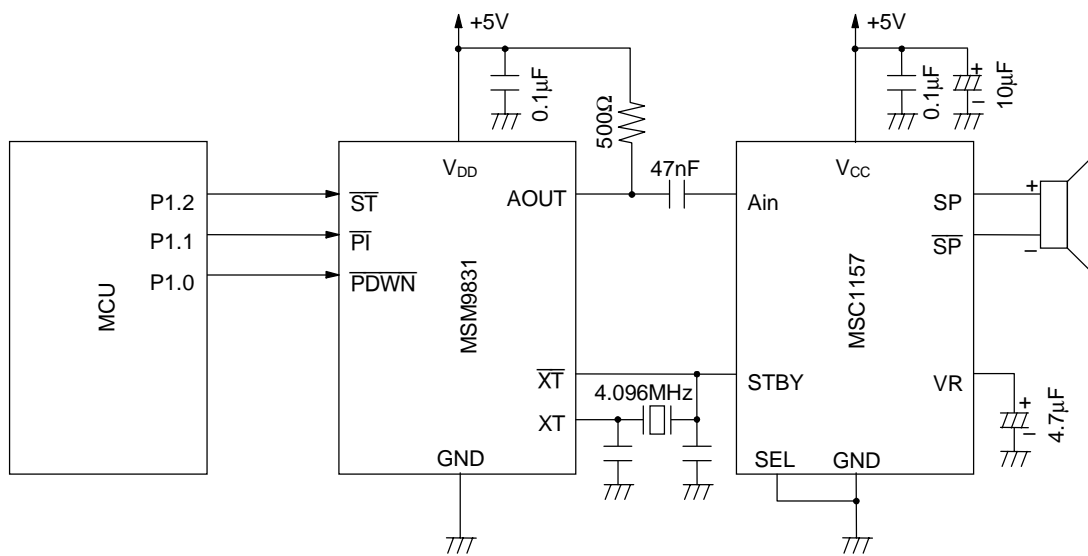

(Ceramic oscillation is selected)

CIRCUIT CONNECTION EXAMPLE 2: WHEN $V_{DD} = 3.0V$ AND THE AMPLITUDE OF AIN OF THE MSC1157 IS $1.5V_{P-P}$

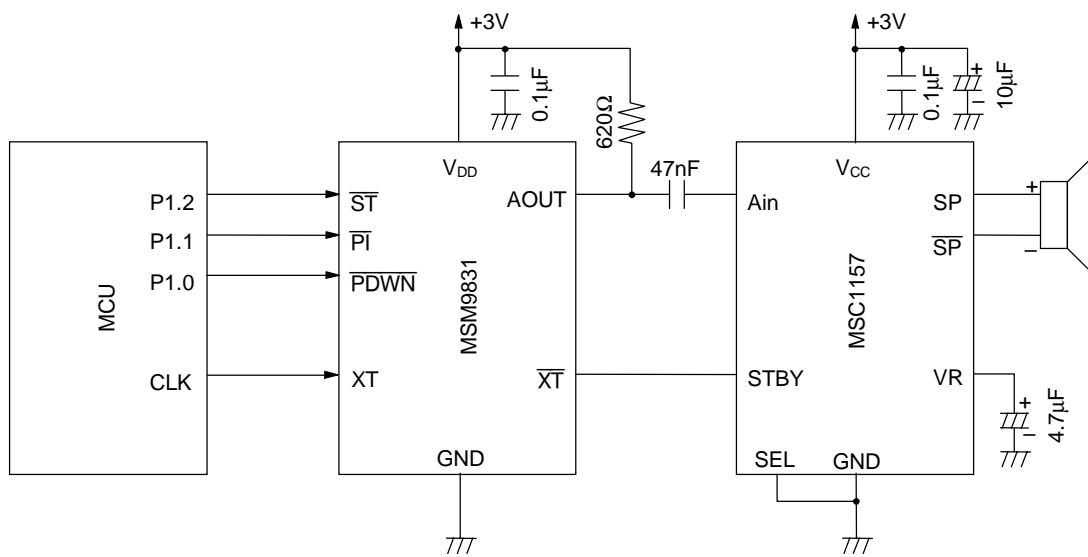

(External clock is selected)

Use a resistor with an appropriate value (R_L) considering the output voltage (reference the drawing below).

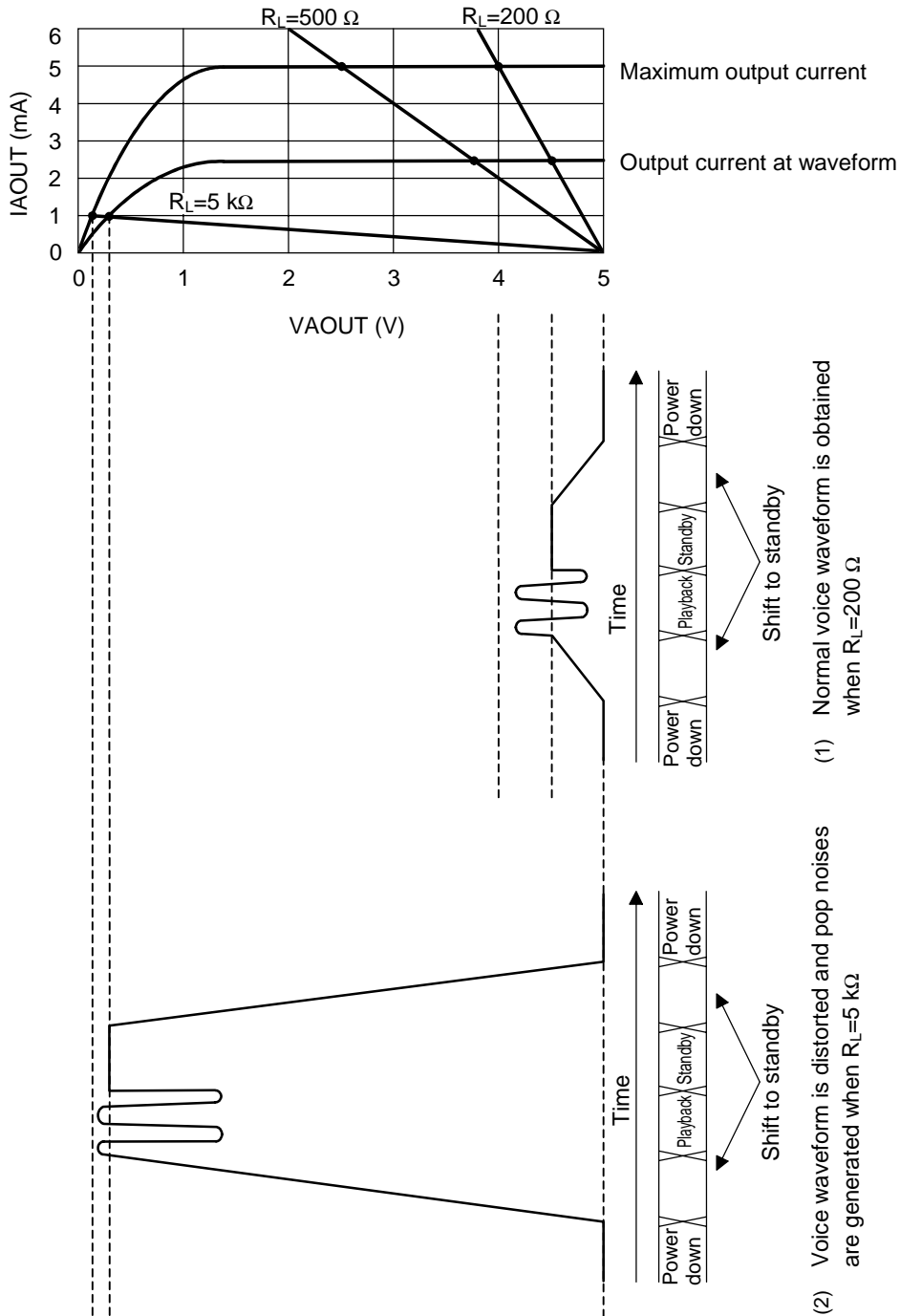

Relationship between AOUT pin voltage and AOUT output current at $V_{DD} = 5 \text{ V}$

D/A CONVERTER OUTPUT CURRENT

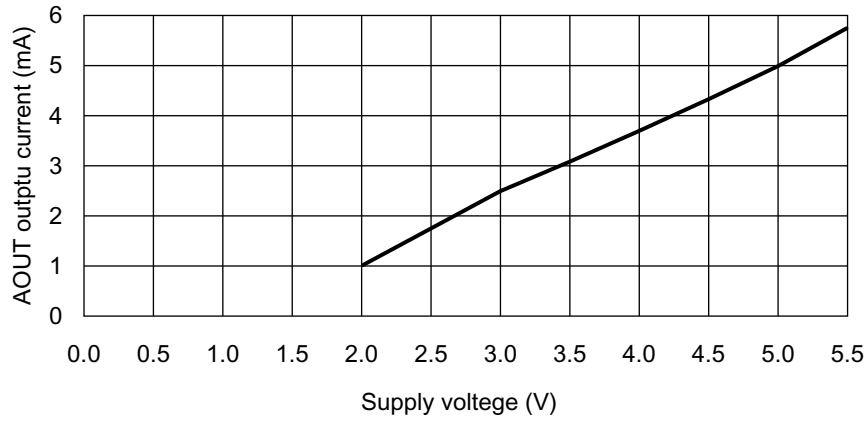

**Relationship between supply voltage and AOUT output current
($T_a = 20^\circ\text{C}$, $V_{AOUT} = V_{DD}$, PCM at maximum)**

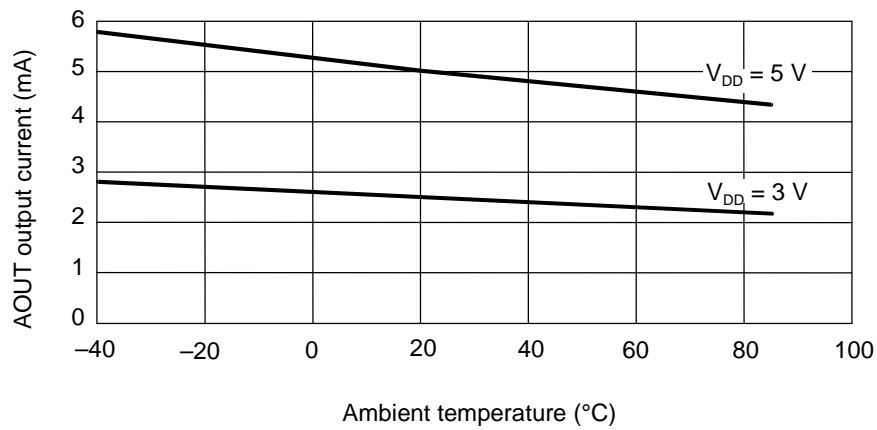

**Relationship between ambient temperature and AOUT output current
($V_{AOUT} = V_{DD}$, PCM at maximum)**

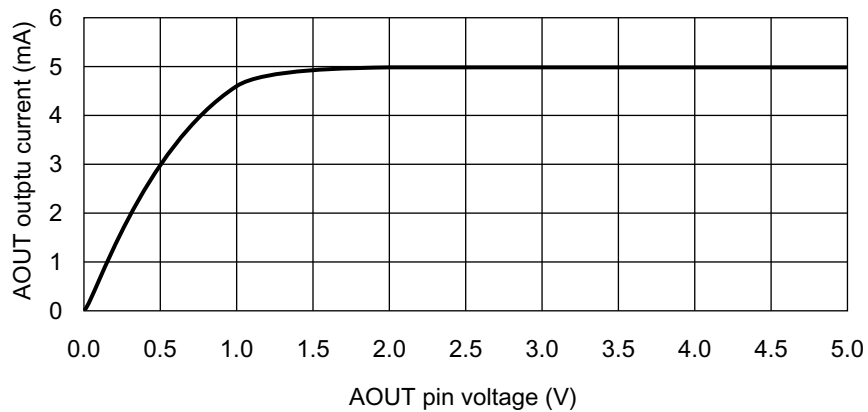

**Relationship between AOUT pin voltage and AOUT output current
($T_a = 25^\circ\text{C}$, $V_{DD} = 5.0\text{ V}$, PCM at maximum)**

NOTES

Internal Converter Circuit

The MSM9831 has not employed a voltage output type D/A converter but a current output type D/A converter. Therefore, the voice output circuit of the MSM9831 is different from that of the MSM6650 family product which has employed a voltage output type D/A converter. The voice output circuit of the MSM9831 also is different from that of the MSM9800 family product because the MSM9831 has employed a current flowing-in type D/A converter and the MSM9800 family product has employed a current flowing-out type D/A converter. (See the table below)

Product name	D/A converter circuit type	D/A converter output circuit
MSM6650 family	Voltage output type	—
MSM9800 family	Current output (flowing-out) type	P-MOS open drain
MSM9831	Current output (flowing-in) type	N-MOS open drain

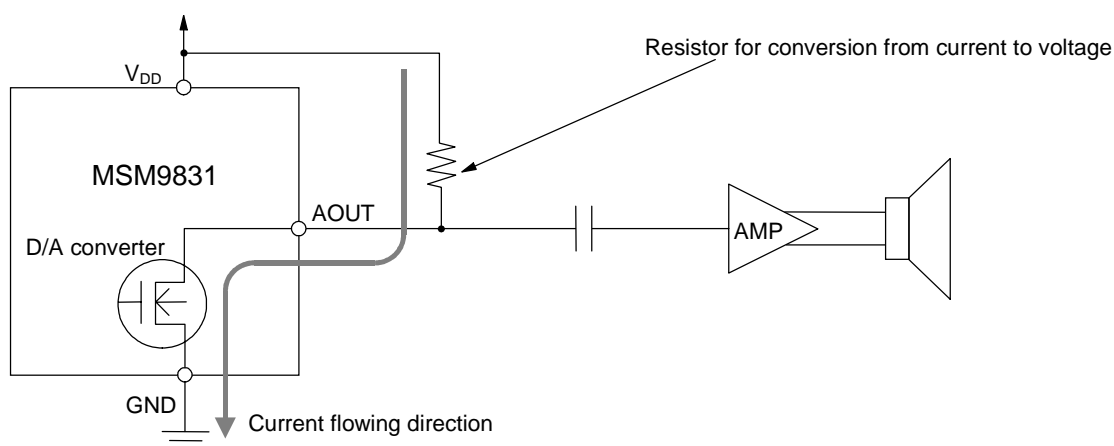

Circuit connection between the MSM9831 and amplifier IC

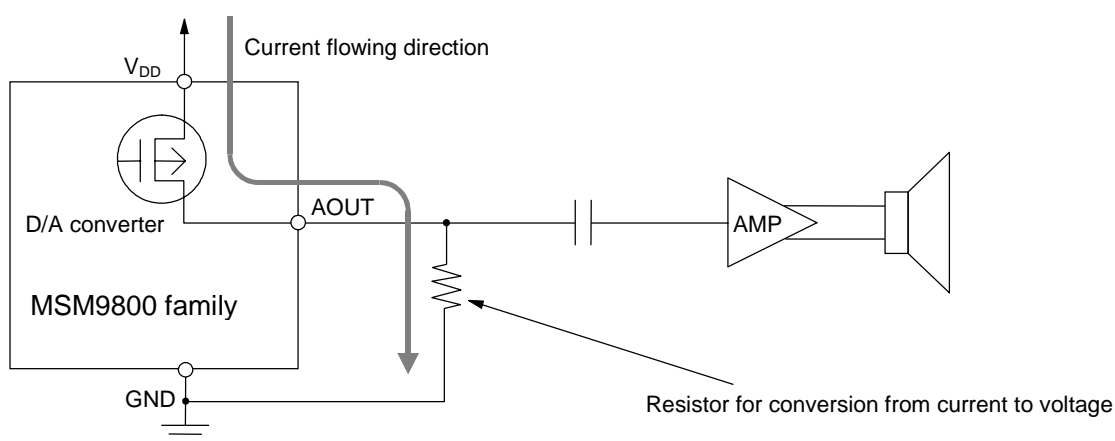

Circuit connection between the MSM9800 family product and amplifier IC

Ceramic Oscillator

A crystal that is usable in this LSI is described in "Functional Description" of this document. If you want to use another crystal, it is recommended to evaluate the crystal before using it.

PACKAGE DIMENSIONS

(Unit: mm)

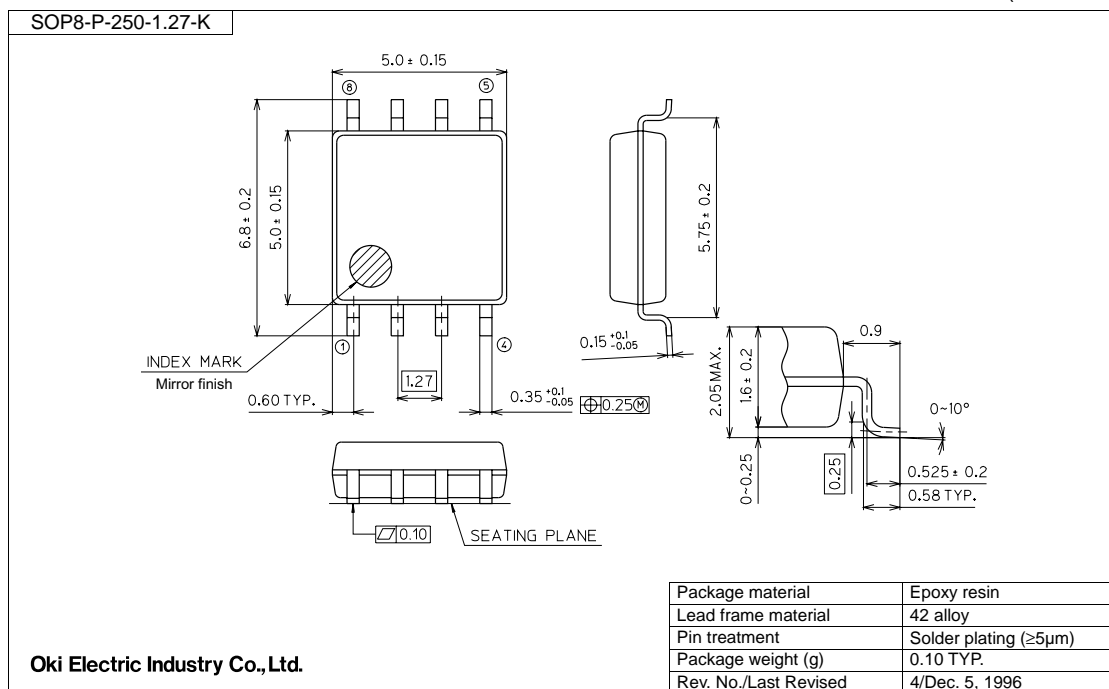

Notes for Mounting the Surface Mount Type Package

The surface mount type packages are very susceptible to heat in reflow mounting and humidity absorbed in storage.

Therefore, before you perform reflow mounting, contact Oki's responsible sales person for the product name, package name, pin number, package code and desired mounting conditions (reflow method, temperature and times).

NOTICE

1. The information contained herein can change without notice owing to product and/or technical improvements. Before using the product, please make sure that the information being referred to is up-to-date.
2. The outline of action and examples for application circuits described herein have been chosen as an explanation for the standard action and performance of the product. When planning to use the product, please ensure that the external conditions are reflected in the actual circuit, assembly, and program designs.
3. When designing your product, please use our product below the specified maximum ratings and within the specified operating ranges including, but not limited to, operating voltage, power dissipation, and operating temperature.
4. Oki assumes no responsibility or liability whatsoever for any failure or unusual or unexpected operation resulting from misuse, neglect, improper installation, repair, alteration or accident, improper handling, or unusual physical or electrical stress including, but not limited to, exposure to parameters beyond the specified maximum ratings or operation outside the specified operating range.
5. Neither indemnity against nor license of a third party's industrial and intellectual property right, etc. is granted by us in connection with the use of the product and/or the information and drawings contained herein. No responsibility is assumed by us for any infringement of a third party's right which may result from the use thereof.
6. The products listed in this document are intended for use in general electronics equipment for commercial applications (e.g., office automation, communication equipment, measurement equipment, consumer electronics, etc.). These products are not authorized for use in any system or application that requires special or enhanced quality and reliability characteristics nor in any system or application where the failure of such system or application may result in the loss or damage of property, or death or injury to humans. Such applications include, but are not limited to, traffic and automotive equipment, safety devices, aerospace equipment, nuclear power control, medical equipment, and life-support systems.
7. Certain products in this document may need government approval before they can be exported to particular countries. The purchaser assumes the responsibility of determining the legality of export of these products and will take appropriate and necessary steps at their own expense for these.
8. No part of the contents contained herein may be reprinted or reproduced without our prior permission.

Copyright 2001 Oki Electric Industry Co., Ltd.