

Helping Customers Innovate, Improve & Grow

## Features

- Any frequency between 220-625 MHz with 6 decimal places of accuracy
- < 1ps RMS phase jitter over 12 kHz to 20 MHz bandwidth
- LVPECL and LVDS output options
- Industrial and extended commercial temperature ranges
- Industry-standard packages: 5.0 mm x 3.2 mm and 7.0 mm x 5.0 mm

## Applications

- SONET, Video, Instrumentation, Satellite Telecom, networking, broadband

## Performance Specifications

Parameter and Conditions	Symbol	Min.	Typ.	Max.	Unit	Condition
<b>LVPECL and LVDS, Common AC Characteristics</b>						
Output Frequency Range	f	220	–	625	MHz	For frequency coverage see last page
Frequency Stability	F_stab	-25	–	+25	PPM	Inclusive of Initial tolerance at 25 °C, and variations over operating temperature, aging, supply voltage and load
		-50	–	+50	PPM	
1-year Aging		-1	–	+1	PPM	First year @ 25°C
10-year Aging		-5	–	+5	PPM	@ 85°C
Operating Temperature Range	T_use	-40	–	+85	°C	Industrial
		-20	–	+70	°C	Extended Commercial
Start-up Time	T_start	–	–	10	ms	
Duty Cycle	DC	45	–	55	%	f = 220 to 312.5 MHz and f = 525 to 625 MHz
		40	–	60	%	f = 420 to 500 MHz
Pull Range	PR	±50, ±80, ±100			PPM	
Upper Control Voltage	VC_U	3	–	3.1	V	Vdd = 3.3V, Voltage at which maximum deviation is guaranteed
		2.25	–	2.3	V	Vdd = 2.5V, Voltage at which maximum deviation is guaranteed
Lower Control Voltage	VC_L	0	–	0.1	V	Voltage at which maximum deviation is guaranteed
Linearity	Lin	–	0.2	1	%	
Frequency Change Polarity		Positive Slope				
Control Voltage Bandwidth (-3dB)	V_BW	–	8	–	kHz	Contact Vectron for 16 kHz bandwidth
<b>LVPECL, DC and AC Characteristics</b>						
Supply Voltage	Vdd	2.97	3.3	3.63	V	
		2.25	2.5	2.75	V	
Current Consumption	Idd	–	61	69	mA	Excluding Load Termination Current, Vdd = 3.3V or 2.5V
OE Disable Supply Current	I_OE	–	–	35	mA	OE = GND
Output Disable Leakage Current	I_leak	–	–	1	µA	OE = GND
Maximum Output Current	I-driver	–	–	30	mA	Maximum average current drawn from OUT+ or OUT-
Output High Voltage	VOH	Vdd-1.1	–	Vdd-0.7	V	See Figure 1
Output Low Voltage	VOL	Vdd-1.9	–	Vdd-1.5	V	See Figure 1
Output Differential Voltage Swing	V_Swing	1.2	1.6	2.0	V	See Figure 1
Rise/Fall Time	Tr, Tf	–	300	500	ps	20% to 80%
OE Enable/Disable Time	T_oe	–	–	102	ns	f = 625 MHz - For other frequencies, T_oe = 100ns + 3 period
RMS Period Jitter	T_jitt	–	1.2	1.7	ps	f = 266 MHz, VDD = 3.3V or 2.5V
		–	1.2	1.7	ps	f = 312.5 MHz, VDD = 3.3V or 2.5V
		–	1.2	1.7	ps	f = 622.08 MHz, VDD = 3.3V or 2.5V
RMS Phase Jitter (random)	T_phj	–	0.6	1.0	ps	f = 312.5 MHz, Integration bandwidth = 12 kHz to 20 MHz, all Vdds

## Performance Specifications (Continued)

Parameter and Conditions	Symbol	Min.	Typ.	Max.	Unit	Condition
<b>LVDS, DC, and AC Characteristics</b>						
Supply Voltage	Vdd	2.97	3.3	3.63	V	
		2.25	2.5	2.75	V	
Current Consumption	I <sub>dd</sub>	–	47	55	mA	Excluding Load Termination Current, V <sub>dd</sub> = 3.3V or 2.5V
OE Disable Current	I <sub>OE</sub>	–	–	35	mA	OE = V <sub>dd</sub>
Output Disable Leakage Current	I <sub>leak</sub>	–	–	1	µA	OE = V <sub>dd</sub>
Differential Output Voltage	VOD	200	350	500	mV	See Figure 4
VOD Magnitude Change	ΔVOD	–	–	50	mV	See Figure 4
Offset Voltage	VOS	1.125	1.2	1.375	V	See Figure 4
VOS Magnitude Change	ΔVOS	–	–	50	mV	See Figure 4
Rise/Fall Time	T <sub>r</sub> , T <sub>f</sub>	360	495	600	ps	20% to 80%
OE Enable/Disable Time	T <sub>oe</sub>	–	–	102	ns	f = 625 MHz - For other frequencies, T <sub>oe</sub> = 100ns + 3 period
RMS Period Jitter	T <sub>jitt</sub>	–	1.4	1.7	ps	f = 266 MHz, VDD = 3.3V or 2.5V
		–	1.4	1.7	ps	f = 312.5 MHz, VDD = 3.3V or 2.5V
		–	1.2	1.7	ps	f = 622.08 MHz, VDD = 3.3V or 2.5V
RMS Phase Jitter (random)	T <sub>phj</sub>	–	0.6	1.0	ps	f = 312.5 MHz, Integration bandwidth = 12 kHz to 20 MHz, all V <sub>dd</sub>

## Typical Phase Noise Data

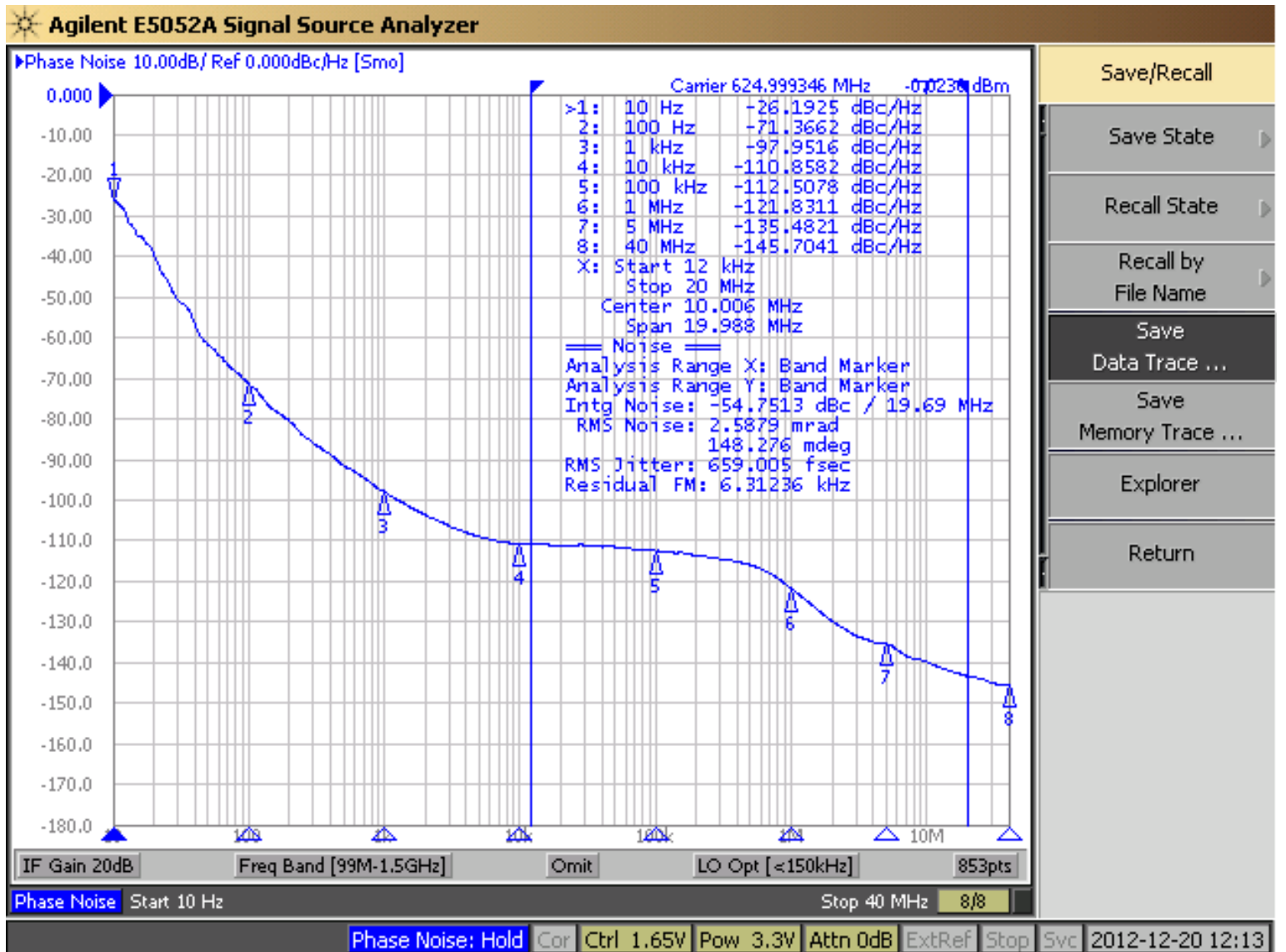

# Packaging

## Package Outline & Dimensions (Unit: mm)

5.0 x 3.2 x 0.75 mm

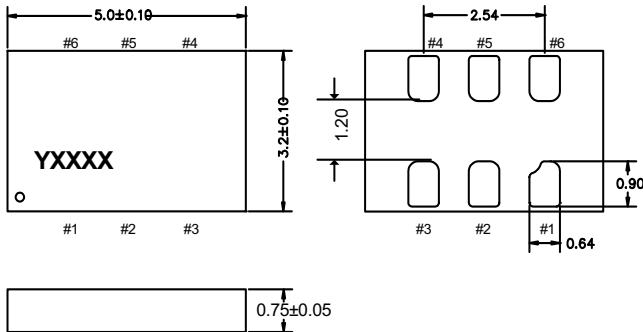

## Recommended Land Pattern (Unit: mm)

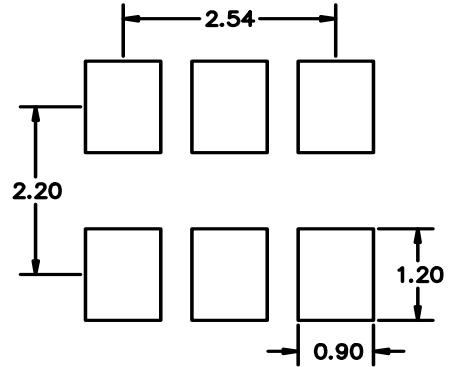

7.0 x 5.0 x 0.90 mm

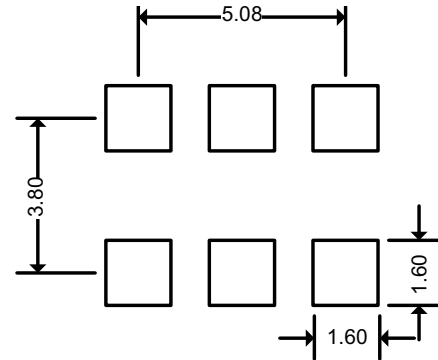
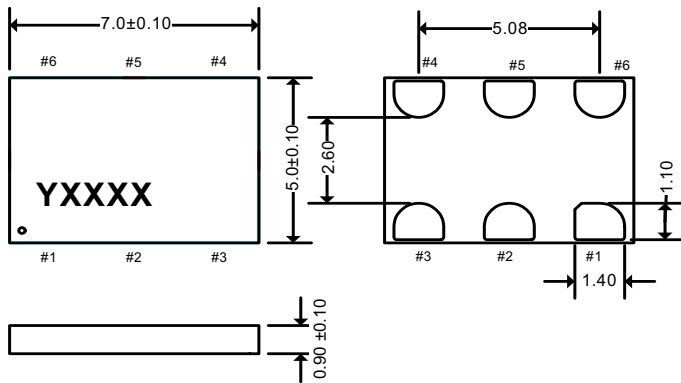

# Pin Assignments

## 6 pin package: Pin Connections

Pin	Symbol	Functionality
1	VIN	Input Control Voltage
2	OE	Input H or Open: specified frequency output L: output is high impedance
3	GND	Power VDD Power Supply Ground
4	OUT+	Output Oscillator output
5	OUT-	Output Complementary oscillator output
6	VDD	Power Power supply voltage

## Top View

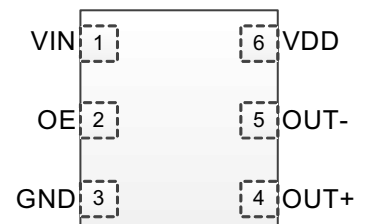

# Termination Circuit Examples

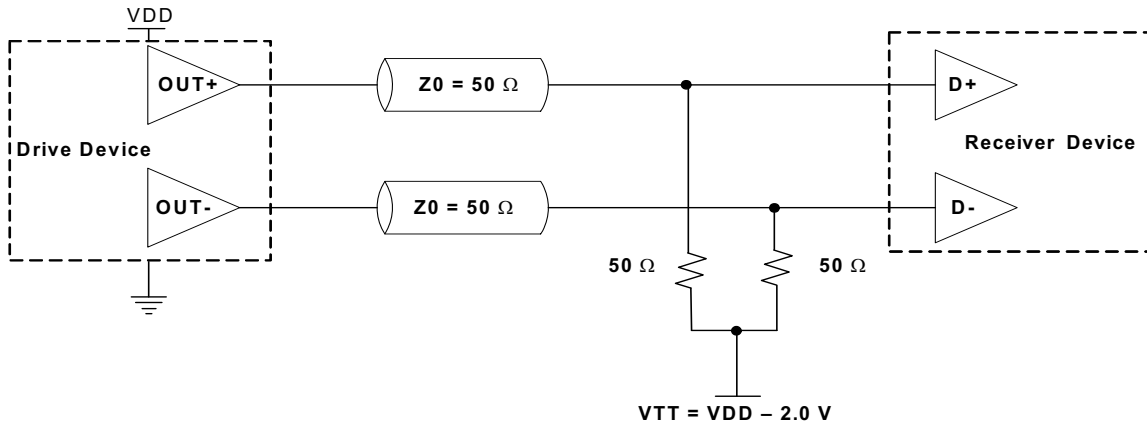

Figure 1. LVPECL Typical Termination

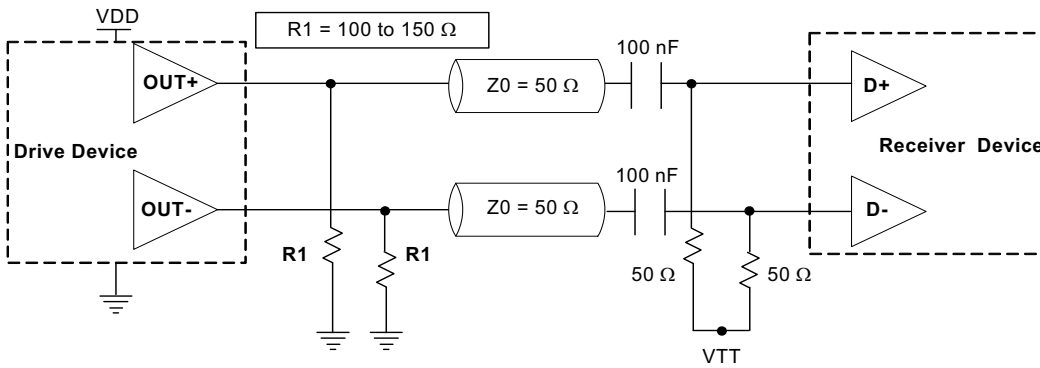

Figure 2. LVPECL AC Coupled Termination

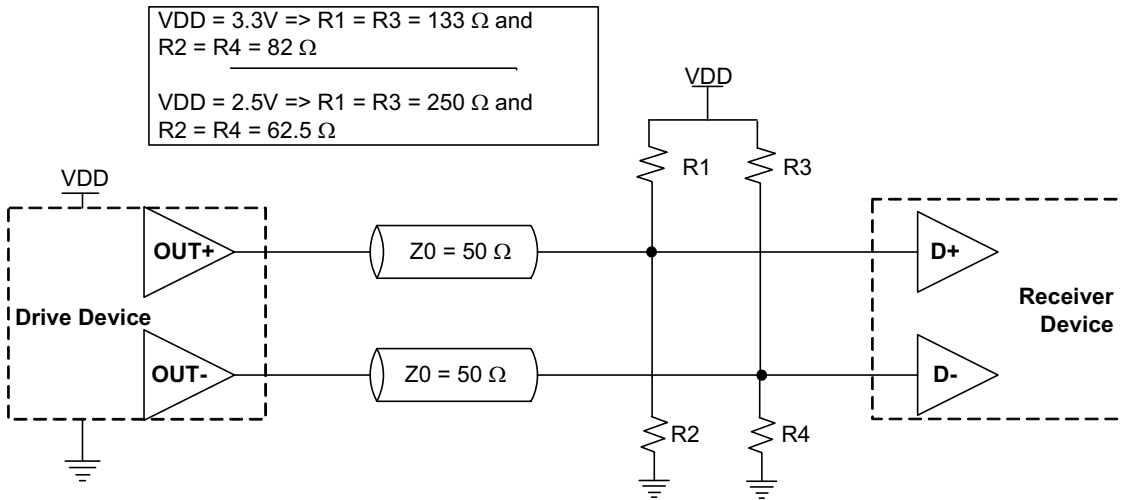

Figure 3. LVPECL with Thevenin Typical Termination

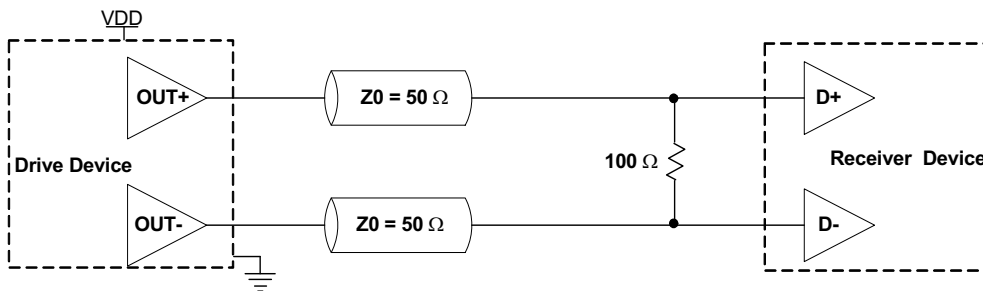

Figure 4. LVDS Single Termination (Load Terminated)

## Absolute Maximum Ratings and Test Compliance

Maximum Ratings			
Parameter	Min.	Max.	Unit
Storage Temperature	-65	150	°C
VDD	-0.5	4	V
Electrostatic Discharge	–	2000	V
Soldering Temperature (follow standard Pb free soldering guidelines)	–	260	°C
Program Retention over -40 to 125°C, Process, Vdd (0 to 3.65 V)	1,000+	-	Years

Environmental Compliance	
Parameter	Condition/Test Method
Mechanical Shock	MIL-STD-883F, Method 2002
Mechanical Vibration	MIL-STD-883F, Method 2007
Temperature Cycle	JESD22, Method A104
Solderability	MIL-STD-883F, Method 2003
Moisture Sensitivity Level	MSL1 @ 260°C

## Ordering Information

### MV - 9450A E - C 3 F - E E K 300M000000

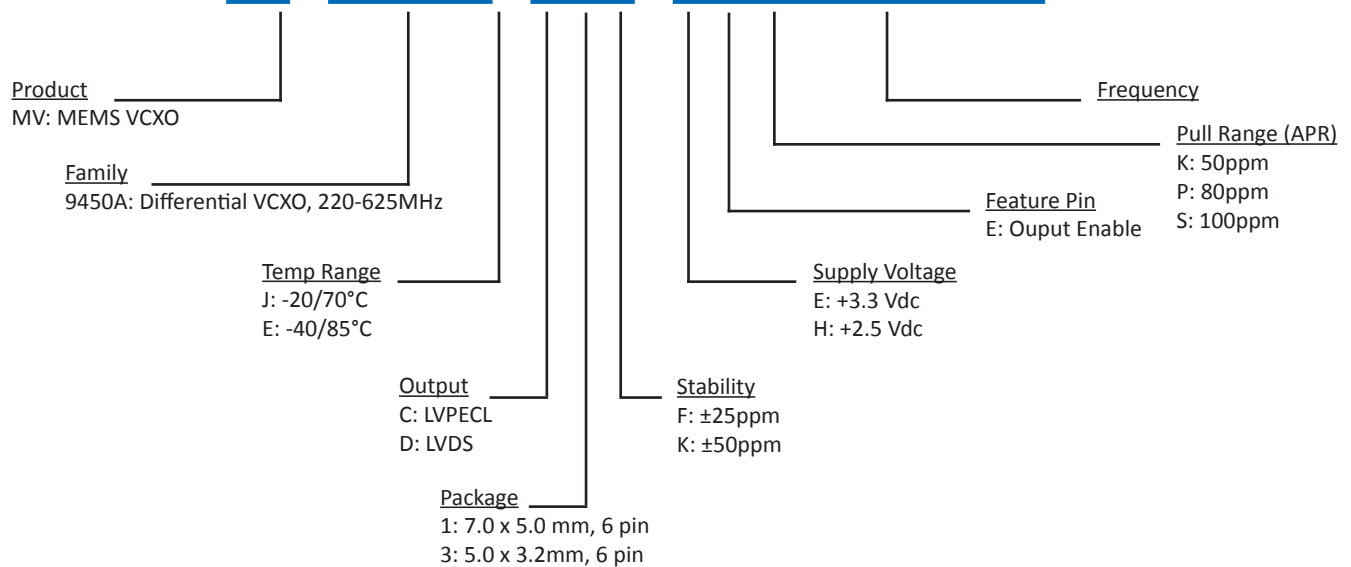

#### Frequency Ranges Not Supported

Range 1	209.000001 MHz to 210.999999 MHz
Range 2	251.000001 MHz to 263.999999 MHz
Range 3	314.000001 to 422.999999 MHz
Range 4	502.000001 to 527.999999 MHz

#### Notes:

- Contact factory for improved stabilities or additional product options. Not all options and codes are available at all frequencies.
- Unless otherwise stated all values are valid after warm-up time and refer to typical conditions for supply voltage, frequency control voltage, load, temperature (25°C).
- Subject to technical modification.
- Contact factory for availability.

## For Additional Information, Please Contact

#### USA:

Vectron International  
267 Lowell Road, Suite 102  
Hudson, NH 03051  
Tel: 1.888.328.7661  
Fax: 1.888.329.8328

#### Europe:

Vectron International  
Landstrasse, D-74924  
Neckarbischofsheim, Germany  
Tel: +49 (0) 7268.801.100  
Fax: +49 (0) 7268.801.282

#### Asia:

68 Yin Cheng Road(C), 22nd Floor  
One Lu Jia Zui  
Pudong, Shanghai 200120, China  
Tel: +86 21 6194 6886  
Fax: +86 21 6194 6699

#### Disclaimer

Vectron International reserves the right to make changes to the product(s) and or information contained herein without notice. No liability is assumed as a result of their use or application. No rights under any patent accompany the sale of any such product(s) or information.