

RD74HV8T07

High-Voltage 8-bit Buffer Gates (with Open Drain Outputs)

REJ03D0901-0200
Rev.2.00
Mar 23, 2009

Description

The RD74HV8T07 has eight Buffer gates (with open drain outputs) in a 20 pin package. The voltage of maximum 30 V can be impressed to the drain-source voltage. Supports the wide power supply voltage and can use it for the other use as a general-purpose driver.

Features

- Wide supply voltage range : 4.5 to 30 V
- Output voltage : V_{DS} (Max.) = 30 V
- Operating temperature range : -40 to $+85^{\circ}\text{C}$
- All inputs V_{IH} (Min.) = 2.4 V, V_{IL} (Max.) = 0.8 V (@ V_{CC} = 10 V to 30 V)
- Output current : I_O short (Typ.) = ± 70 mA (@ V_{CC} = 15 V)
- Ordering Information

Part Name	Package Type	Package Code (Previous Code)	Package Abbreviation	Packing Abbreviation (Quantity)	Surface Treatment
RD74HV8T07FPH0	SOP-20 pin (JEITA)	PRSP0020DD-B (FP-20DAV)	FP	H (2,000 pcs/reel)	0 (Ni/Pd/Au)
RD74HV8T07TH0	TSSOP-20 pin	PTSP0020JB-A (TTP-20DAV)	T	H (2,000 pcs/reel)	0 (Ni/Pd/Au)

Note: Please consult the sales office for the above package availability.

Pin Arrangement

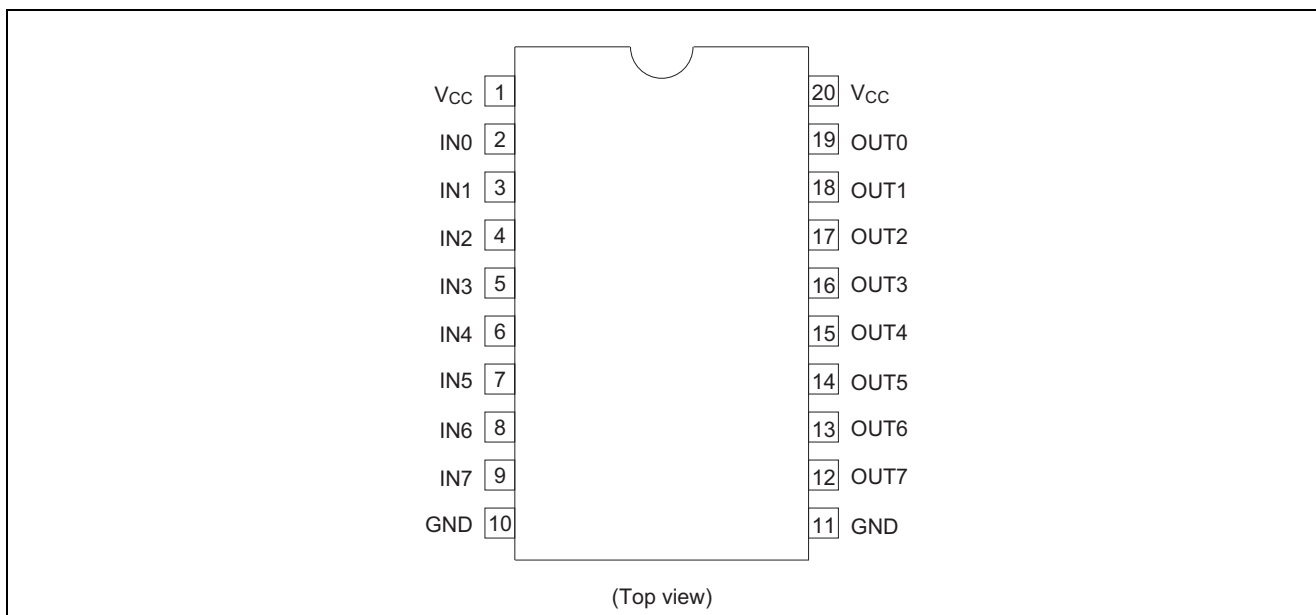

These products designed for general and industrial use.
It is not supported for special quality or reliability demanded use such as automotive or life support or something like that.

Logic Diagram

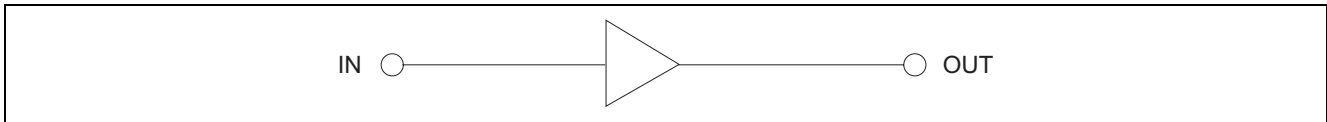

Function Table

Input	Output
H	H
L	L

H : High level

L : Low level

Absolute Maximum Ratings

Item	Symbol	Ratings	Unit	Test Conditions
Supply voltage range	V_{CC}	0 to 30	V	
Input voltage range ^{*1}	V_I	-0.5 to $V_{CC} + 0.5$	V	
Output voltage range ^{*1, 2}	V_O	-0.5 to 30	V	
Input clamp current	I_{IK}	± 50	mA	$V_I < 0$ or $V_I > V_{CC}$
Output clamp current	I_{OK}	-75	mA	$V_O < 0$
Continuous output current	I_O	100	mA	Output: L
Continuous current through V_{CC} or GND	I_{CC} or I_{GND}	± 100	mA	
Maximum power dissipation at $T_a = 25^\circ\text{C}$ (in still air) ^{*3}	P_T	835	mW	SOP
		757		TSSOP
Storage temperature	T_{stg}	-65 to 150	$^\circ\text{C}$	

Notes: The absolute maximum ratings are values which must not individually be exceeded, and furthermore no two of which may be realized at the same time.

1. The input and output voltage ratings may be exceeded if the input and output clamp-current ratings are observed.
2. This value is limited to 30 V maximum.
3. The maximum package power dissipation was calculated using a junction temperature of 150°C .

Recommended Operating Conditions

Item	Symbol	Min	Max	Unit	Conditions
Supply voltage range	V_{CC}	4.5	30	V	
Input voltage range	V_I	0	V_{CC}	V	
Output voltage range	V_O	0	30	V	
Output current	I_{OL}	—	2.5	mA	$V_{CC} = 10\text{ V}$
		—	5		$V_{CC} = 15\text{ V}$
		—	10		$V_{CC} = 25\text{ V}$
		—	15		$V_{CC} = 30\text{ V}$
Input transition rise or fall rate	$\Delta t / \Delta v$	0	100	ns / V	$V_{CC} < 5\text{ V}$
		0	20		$15\text{ V} > V_{CC} \geq 5\text{ V}$
		0	10		$30\text{ V} \geq V_{CC} \geq 15\text{ V}$
Operating free-air temperature	T_a	-40	85	$^\circ\text{C}$	

Note: Unused or floating inputs must be held high or low.

Electrical Characteristics

(Ta = -40 to 85°C)

Item	Symbol	V _{CC} (V) *	Min	Typ	Max	Unit	Test condition
Input voltage	V _{IH}	10	2.4	—	—	V	
		15	2.4	—	—		
		25	2.4	—	—		
		30	2.4	—	—		
	V _{IL}	10	—	—	0.8		
		15	—	—	0.8		
		25	—	—	0.8		
		30	—	—	0.8		
Output voltage	V _{OL}	10	—	—	1.0	V	I _{OL} = 2.5 mA
		15	—	—	1.0		I _{OL} = 5 mA
		25	—	—	1.5		I _{OL} = 10 mA
		30	—	—	2.0		I _{OL} = 15 mA
Output current	I _{OL short}	15	46	70	95	mA	V _O = V _{CC}
Input current	I _{IN}	V _{CC}	—	—	±1	μA	V _{IN} = V _{CC} or GND
Output off state leak current	I _{DS}	30	—	—	2.0	μA	V _{DS} = 30 V
Quiescent supply current	I _{CC}	10	—	—	0.5	μA	V _{IN} = V _{CC} or GND
		15	—	—	1.0		
		25	—	—	2.0		
		30	—	—	2.0		
Supply current	I _{SUPP}	10	—	—	1	mA	V _{CC} = 10 V, V _{IN} = 3.0 V
		30	—	—	2.0		V _{CC} = 30 V, V _{IN} = 3.0 V
Input capacitance	C _{IN}	V _{CC}	—	2.5	—	pF	V _{IN} = V _{CC} or GND

Note: For conditions shown as Min or Max, use the appropriate values under recommended operating conditions.

Switching Characteristics

(C_L = 50 pF, t_r = t_f = 5 ns)

Item	Symbol	V _{CC} (V)	Ta = -40 to 85°C			Unit	FROM (Input)	TO (Output)
			Min	Typ	Max			
Propagation delay time	t _{PLH}	10	50	—	120	ns	IN	OUT
		15	50	—	120			
		20	50	—	120			
		25	50	—	120			
		30	50	—	120			
	t _{PHL}	10	30	—	200	ns	IN	OUT
		15	30	—	200			
		20	20	—	120			
		25	20	—	120			
		30	20	—	120			
Output rise / fall time	t _{TLH}	10	—	—	300	ns	IN	OUT
		15	—	—	300			
		20	—	—	300			
		25	—	—	300			
		30	—	—	300			
	t _{THL}	10	2	—	30	ns	IN	OUT
		15	2	—	30			
		20	2	—	30			
		25	2	—	30			
		30	2	—	30			

Test Circuit

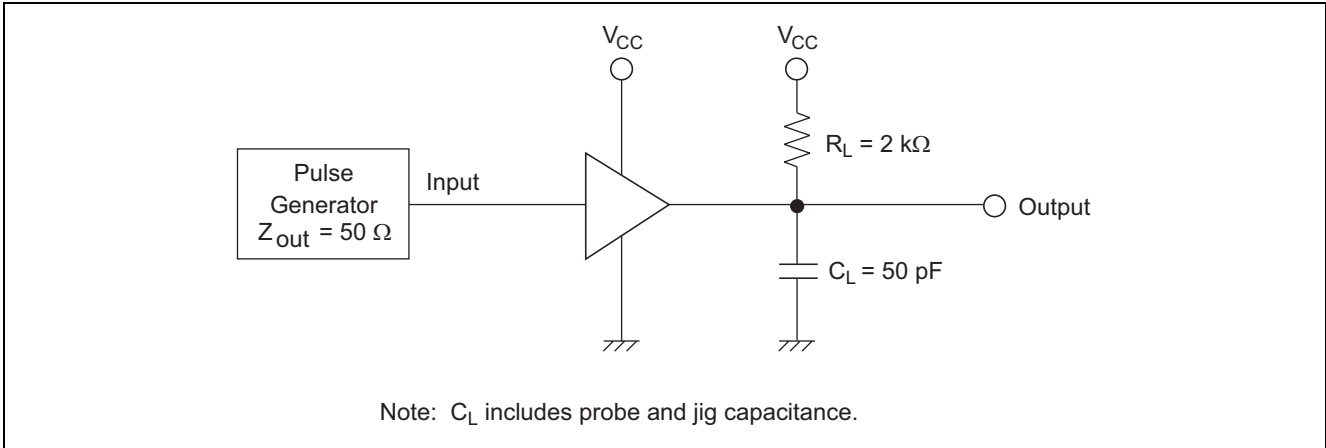

Waveforms

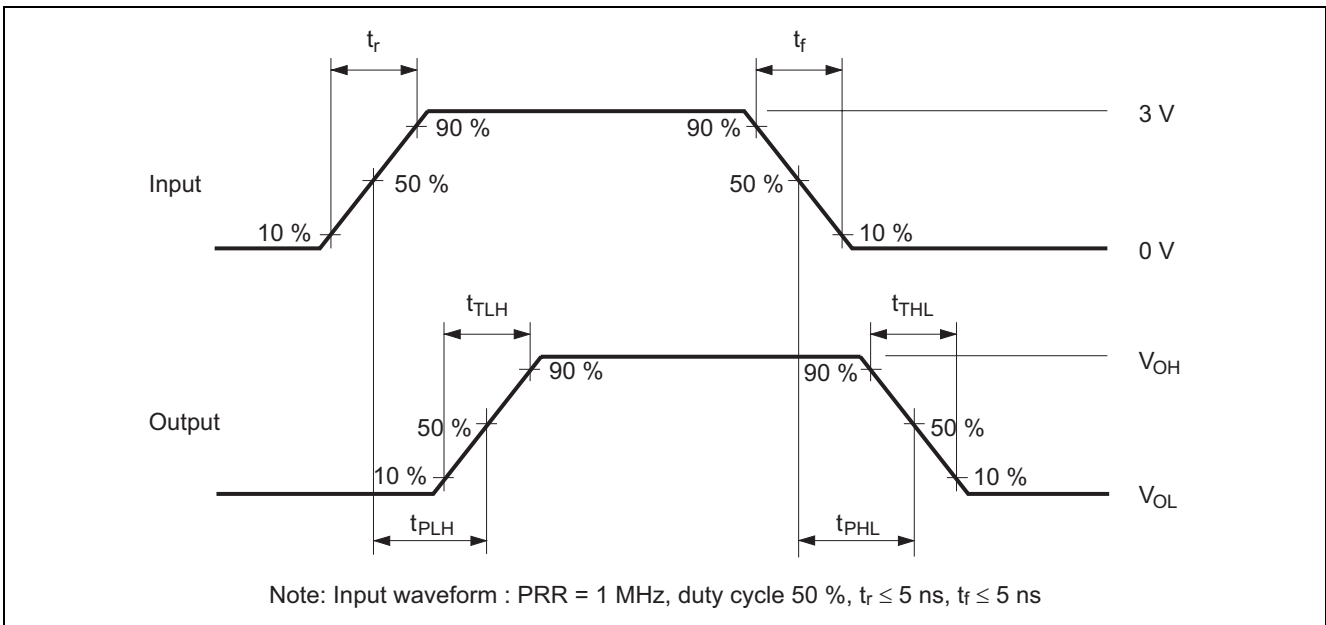

Package Dimensions

JEITA Package Code	RENESAS Code	Previous Code	MASS[Typ.]
P-SOP20-5.5x12.6-1.27	PRSP0020DD-B	FP-20DAV	0.31g

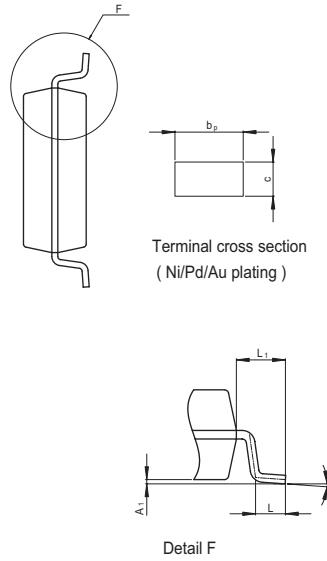
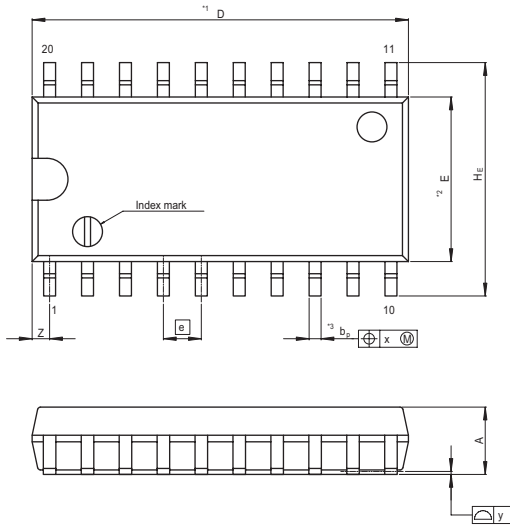

NOTE)
 1. DIMENSIONS**1 (Nom)**AND**2*
 DO NOT INCLUDE MOLD FLASH.
 2. DIMENSION**3*DOES NOT
 INCLUDE TRIM OFFSET.

Reference Symbol	Dimension in Millimeters		
	Min	Nom	Max
D	—	12.60	13.0
E	—	5.50	—
A ₂	—	—	—
A ₁	0.00	0.10	0.20
A	—	—	2.20
b _P	0.34	0.40	0.46
b ₁	—	—	—
c	0.15	0.20	0.25
c ₁	—	—	—
θ	0°	—	8°
H _E	7.50	7.80	8.00
Ⓧ	—	1.27	—
x	—	—	0.12
y	—	—	0.15
Z	—	—	0.80
L	0.50	0.70	0.90
L ₁	—	1.15	—

JEITA Package Code	RENESAS Code	Previous Code	MASS[Typ.]
P-TSSOP20-4.4x6.5-0.65	PTSP0020JB-A	TTP-20DAV	0.07g

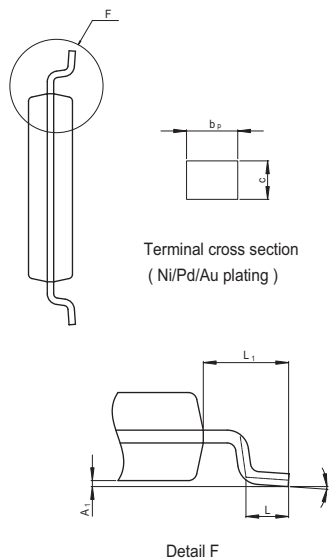
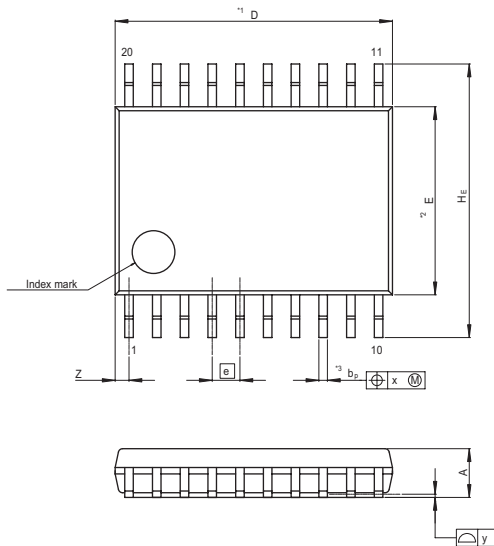

NOTE)
 1. DIMENSIONS**1 (Nom)**AND**2*
 DO NOT INCLUDE MOLD FLASH.
 2. DIMENSION**3*DOES NOT
 INCLUDE TRIM OFFSET.

Reference Symbol	Dimension in Millimeters		
	Min	Nom	Max
D	—	6.50	6.80
E	—	4.40	—
A ₂	—	—	—
A ₁	0.03	0.07	0.10
A	—	—	1.10
b _P	0.15	0.20	0.25
b ₁	—	—	—
c	0.10	0.15	0.20
c ₁	—	—	—
θ	0°	—	8°
H _E	6.20	6.40	6.60
Ⓧ	—	0.65	—
x	—	—	0.13
y	—	—	0.10
Z	—	—	0.65
L	0.4	0.5	0.6
L ₁	—	1.0	—

Notes:

1. This document is provided for reference purposes only so that Renesas customers may select the appropriate Renesas products for their use. Renesas neither makes warranties or representations with respect to the accuracy or completeness of the information contained in this document nor grants any license to any intellectual property rights or any other rights of Renesas or any third party with respect to the information in this document.
2. Renesas shall have no liability for damages or infringement of any intellectual property or other rights arising out of the use of any information in this document, including, but not limited to, product data, diagrams, charts, programs, algorithms, and application circuit examples.
3. You should not use the products or the technology described in this document for the purpose of military applications such as the development of weapons of mass destruction or for the purpose of any other military use. When exporting the products or technology described herein, you should follow the applicable export control laws and regulations, and procedures required by such laws and regulations.
4. All information included in this document such as product data, diagrams, charts, programs, algorithms, and application circuit examples, is current as of the date this document is issued. Such information, however, is subject to change without any prior notice. Before purchasing or using any Renesas products listed in this document, please confirm the latest product information with a Renesas sales office. Also, please pay regular and careful attention to additional and different information to be disclosed by Renesas such as that disclosed through our website. (<http://www.renesas.com>)
5. Renesas has used reasonable care in compiling the information included in this document, but Renesas assumes no liability whatsoever for any damages incurred as a result of errors or omissions in the information included in this document.
6. When using or otherwise relying on the information in this document, you should evaluate the information in light of the total system before deciding about the applicability of such information to the intended application. Renesas makes no representations, warranties or guarantees regarding the suitability of its products for any particular application and specifically disclaims any liability arising out of the application and use of the information in this document or Renesas products.
7. With the exception of products specified by Renesas as suitable for automobile applications, Renesas products are not designed, manufactured or tested for applications or otherwise in systems the failure or malfunction of which may cause a direct threat to human life or create a risk of human injury or which require especially high quality and reliability such as safety systems, or equipment or systems for transportation and traffic, healthcare, combustion control, aerospace and aeronautics, nuclear power, or undersea communication transmission. If you are considering the use of our products for such purposes, please contact a Renesas sales office beforehand. Renesas shall have no liability for damages arising out of the uses set forth above.
8. Notwithstanding the preceding paragraph, you should not use Renesas products for the purposes listed below:
 - (1) artificial life support devices or systems
 - (2) surgical implantations
 - (3) healthcare intervention (e.g., excision, administration of medication, etc.)
 - (4) any other purposes that pose a direct threat to human lifeRenesas shall have no liability for damages arising out of the uses set forth in the above and purchasers who elect to use Renesas products in any of the foregoing applications shall indemnify and hold harmless Renesas Technology Corp., its affiliated companies and their officers, directors, and employees against any and all damages arising out of such applications.
9. You should use the products described herein within the range specified by Renesas, especially with respect to the maximum rating, operating supply voltage range, movement power voltage range, heat radiation characteristics, installation and other product characteristics. Renesas shall have no liability for malfunctions or damages arising out of the use of Renesas products beyond such specified ranges.
10. Although Renesas endeavors to improve the quality and reliability of its products, IC products have specific characteristics such as the occurrence of failure at a certain rate and malfunctions under certain use conditions. Please be sure to implement safety measures to guard against the possibility of physical injury, and injury or damage caused by fire in the event of the failure of a Renesas product, such as safety design for hardware and software including but not limited to redundancy, fire control and malfunction prevention, appropriate treatment for aging degradation or any other applicable measures. Among others, since the evaluation of microcomputer software alone is very difficult, please evaluate the safety of the final products or system manufactured by you.
11. In case Renesas products listed in this document are detached from the products to which the Renesas products are attached or affixed, the risk of accident such as swallowing by infants and small children is very high. You should implement safety measures so that Renesas products may not be easily detached from your products. Renesas shall have no liability for damages arising out of such detachment.
12. This document may not be reproduced or duplicated, in any form, in whole or in part, without prior written approval from Renesas.
13. Please contact a Renesas sales office if you have any questions regarding the information contained in this document, Renesas semiconductor products, or if you have any other inquiries.



RENESAS SALES OFFICES

<http://www.renesas.com>

Refer to "<http://www.renesas.com/en/network>" for the latest and detailed information.

Renesas Technology America, Inc.
450 Holger Way, San Jose, CA 95134-1368, U.S.A
Tel: <1> (408) 382-7500, Fax: <1> (408) 382-7501

Renesas Technology Europe Limited
Dukes Meadow, Millboard Road, Bourne End, Buckinghamshire, SL8 5FH, U.K.
Tel: <44> (1628) 585-100, Fax: <44> (1628) 585-900

Renesas Technology (Shanghai) Co., Ltd.
Unit 204, 205, AZIACenter, No.1233 Lujiazui Ring Rd, Pudong District, Shanghai, China 200120
Tel: <86> (21) 5877-1818, Fax: <86> (21) 6887-7858/7898

Renesas Technology Hong Kong Ltd.
7th Floor, North Tower, World Finance Centre, Harbour City, Canton Road, Tsimshatsui, Kowloon, Hong Kong
Tel: <852> 2265-6688, Fax: <852> 2377-3473

Renesas Technology Taiwan Co., Ltd.
10th Floor, No.99, Fushing North Road, Taipei, Taiwan
Tel: <886> (2) 2715-2888, Fax: <886> (2) 3518-3399

Renesas Technology Singapore Pte. Ltd.
1 Harbour Front Avenue, #06-10, Keppel Bay Tower, Singapore 098632
Tel: <65> 6213-0200, Fax: <65> 6278-8001

Renesas Technology Korea Co., Ltd.
Kukje Center Bldg. 18th Fl., 191, 2-ka, Hangang-ro, Yongsan-ku, Seoul 140-702, Korea
Tel: <82> (2) 796-3115, Fax: <82> (2) 796-2145

Renesas Technology Malaysia Sdn. Bhd
Unit 906, Block B, Menara Amcorp, Amcorp Trade Centre, No.18, Jln Persiaran Barat, 46050 Petaling Jaya, Selangor Darul Ehsan, Malaysia
Tel: <603> 7955-9390, Fax: <603> 7955-9510