

- NOTES:
1. FOR USE WITH TIMES AA-2831 & FEP 226 CABLES.
 2. FOR CABLE TRIMMING USE DIE SIZE 177.
 3. FOR CRIMPING USE DIE SIZE 177.
 4. FOR CABLING INSTRUCTIONS SEE CP-5402.
 5. ITEM ⑤ TO BE SUPPLIED UNASSEMBLED.
 6. INTERFACE PER MIL-STD-348, FIG. 309-2.
 7. ITEMS ①, ② & ⑤ TO BE TR-5 FINISH.
 8. MARK PACKAGE: KINGS B21-3-9 XXXX (DATE CODE)

UNLESS OTHERWISE SPECIFIED:

1. TOLERANCES FRACTIONS & PLACE DECIMALS & DIO
2. PLACE DECIMALS & RATIO OF ANY 2 DIAMETERS MAY NOT EXCEED HALF THE SUM OF THEIR TOLERANCES
3. NO FILLETS PERMITTED
4. SURFACE ROUGHNESS IN MICRONS/INCHES RING MAX
5. ALL DIMENSIONS PRIOR TO PLATING
6. ALL PLATING IN ACCORDANCE WITH KER 10004
7. REMOVE ALL BURRS, BREAK SHARP EDGES JOB MAX
8. SURFACE ROUGHNESS IN MICRONS/INCHES RING MAX
9. ALL DIMENSIONS PRIOR TO PLATING
10. ALL PLATING IN ACCORDANCE WITH KER 10004

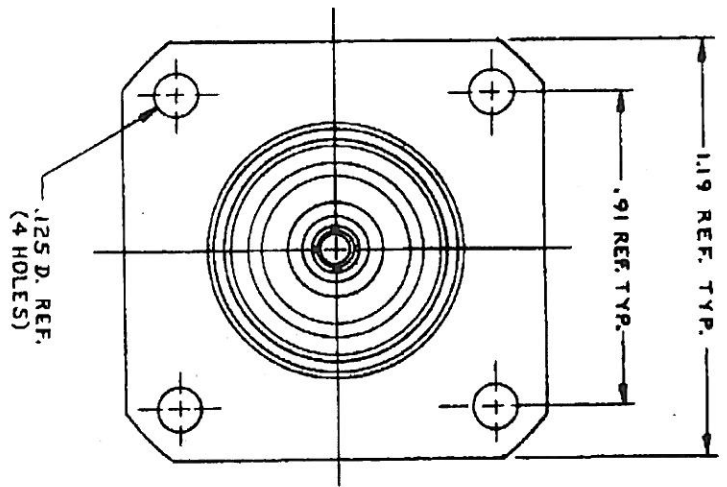

S-D
(SHEET 1 OF 2)

B21-3-9

REVISIONS	
DATE	REVISION
0	ER 50645 KH 16 MAR 89
1	CJ 31044 C JCA 8 AUG 89

SCALE	3:1
APPROVAL	WAS: E-15654
DESIGN	BOEING
SC PANEL JACK	
DATE	16 MAR 89
APPN	JY
DATE	28 MAR 89
KINGS	
B21-3-9	
(SHEET 1 OF 2)	

