

3SK274

GaAs N CHANNEL DUAL GATE MES TYPE FIELD EFFECT TRANSISTOR

TV TUNER, UHF RF AMPLIFIER APPLICATIONS.

Unit in mm

MAXIMUM RATINGS (Ta = 25°C)

CHARACTERISTIC	SYMBOL	RATING	UNIT
Gate1-Drain Voltage	V _{G1DO}	-9	V
Gate2-Drain Voltage	V _{G2DO}	-9	V
Gate1-Source Voltage	V _{G1S}	-4	V
Gate2-Source Voltage	V _{G2S}	-4	V
Gate1 Current	I _{G1}	1	mA
Gate2 Current	I _{G2}	1	mA
Power Dissipation	P _D	100	mW
Channel Temperature	T _{ch}	125	°C
Storage Temperature Range	T _{stg}	-55~125	°C

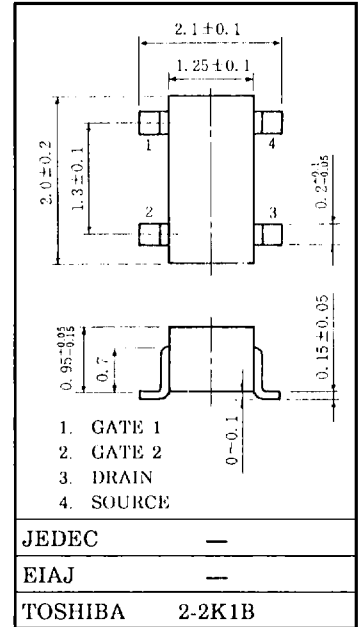

MARKING

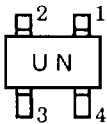

ELECTRICAL CHARACTERISTICS (Ta = 25°C)

Weight : 0.006g

CHARACTERISTIC	SYMBOL	TEST CONDITION	MIN.	TYP.	MAX.	UNIT
Gate1 Leakage Current	I _{G1SS}	V _{DS} =0, V _{G1S} =-3V, V _{G2S} =0	—	—	-4	μA
Gate2 Leakage Current	I _{G2SS}	V _{DS} =0, V _{G1S} =0, V _{G2S} =-3V	—	—	-4	μA
Drain Current	I _{DSS}	V _{DS} =3V, V _{G1S} =0, V _{G2S} =0	6	—	20	mA
Gate1-Source Cut-off Voltage	V _{G1S(OFF)}	V _{DS} =3V, V _{G2S} =0, I _D =100μA	-0.7	—	-1.8	V
Gate2-Source Cut-off Voltage	V _{G2S(OFF)}	V _{DS} =3V, V _{G1S} =0, I _D =100μA	-0.7	—	-1.8	V
Forward Transfer Admittance	Y _{fs}	V _{DS} =3V, V _{G2S} =1V I _D =5mA, f=1kHz	—	19	—	mS
Input Capacitance	C _{iss}	V _{DS} =3V, V _{G2S} =1V I _D =5mA, f=1MHz	—	0.6	1.4	pF
Reverse Transfer Capacitance	C _{rss}		—	0.013	0.030	
Power Gain	G _{ps}	V _{DS} =3V, V _{G2S} =1V I _D =5mA, f=800MHz (Fig 1)	17	20.5	—	dB
Noise Figure	NF		—	1.0	2.0	

CAUTION

GaAs (Gallium Arsenide) is used in this product. The dust or vapor can be dangerous to humans. Do not break, cut, crush or dissolve chemically. Dispose of this product properly according to law. Do not intermingle with normal industrial or domestic waste.

Fig.1 800MHz Gps, NF TEST CIRCUIT

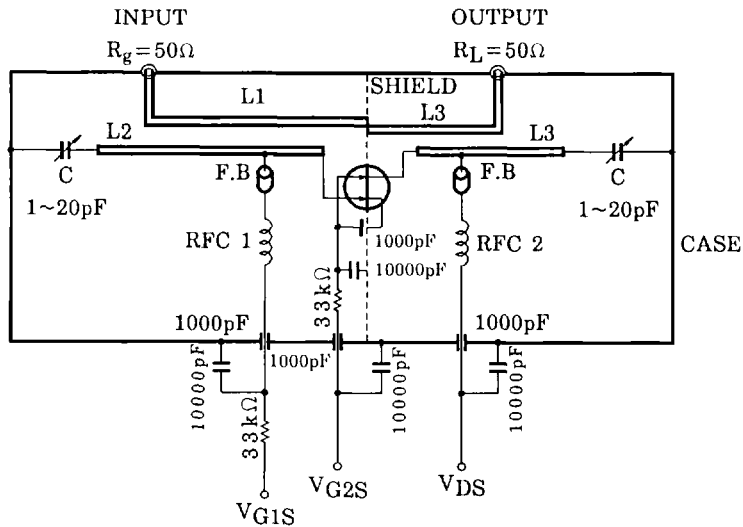

L1~L4 : ϕ 0.8mm SILVER PLATED COPPER WIRE

C : AIR TRIMMER TTA25A 200A (MURATA MFG. Co., LTD.)

RFC 1 : ϕ 0.35mm UEW 3mm ID, 7T

RFC 2 : ϕ 0.35mm UEW 3mm ID, 10T

CAUTION

GaAs (Gallium Arsenide) is used in this product. The dust or vapor can be dangerous to humans. Do not break, cut, crush or dissolve chemically. Dispose of this product properly according to law. Do not intermingle with normal industrial or domestic waste.

