

## 1 Amp BRIDGE RECTIFIER

## DB101 TO DB107

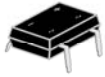

DB-1

**DB-1 Leaded  
Plastic Package  
RoHS compliant**

### FEATURES:

High surge overload rating of 50A peak

### ABSOLUTE MAXIMUM RATINGS (Ta = 25 °C Unless otherwise specified)

PARAMETER	SYMBOL	DB 101	DB 102	DB 103	DB 104	DB 105	DB 106	DB 107	UNIT
Maximum Recurrent Peak Reverse Voltage	$V_{RRM}$	50	100	200	400	600	800	1000	V
Maximum RMS Voltage	$V_{RMS}$	35	70	140	280	420	560	700	V
Maximum DC Blocking Voltage	$V_{DC}$	50	100	200	400	600	800	1000	V
Maximum Average Forward Rectified Current at $T_a=40^\circ\text{C}$	$I_{(AV)}$	1.0							A
Peak Forward Surge Current, 8.3ms single half sine-wave superimposed on rated load (JEDEC method)	$I_{FSM}$	50.0							A
Maximum Forward Voltage at 1.0A DC and 25°C	$V_F$	1.1							V
Maximum Reverse Current at Rated DC Blocking Voltage	$T_a=25^\circ\text{C } I_R$	5.0							$\mu\text{A}$
	$T_a=125^\circ\text{C } I_R$	500							
Typical Junction Capacitance (Note 1)	$C_j$	25							pF
Typical Thermal Resistance (Note 2)	$R_{\theta JA}$	40.0							$^\circ\text{C/W}$
Typical Thermal Resistance (Note 2)	$R_{\theta JL}$	15.0							$^\circ\text{C/W}$
Operating Junction Temperature and Storage Temperature Range	$T_j, T_{stg}$	-55 to +150							$^\circ\text{C}$

#### Note:

1. Measured at 1 MHz and applied reverse voltage of 4.0 VDC
2. Thermal resistance from junction to ambient and from junction to lead mounted on PCB with 0.5 x 0.5" (13 x 13 mm) copper pads



Continental Device India Pvt. Limited

An IATF 16949, ISO9001 and ISO 14001 Certified Company



## PACKAGE DETAIL

DB-1 Leaded Plastic Package

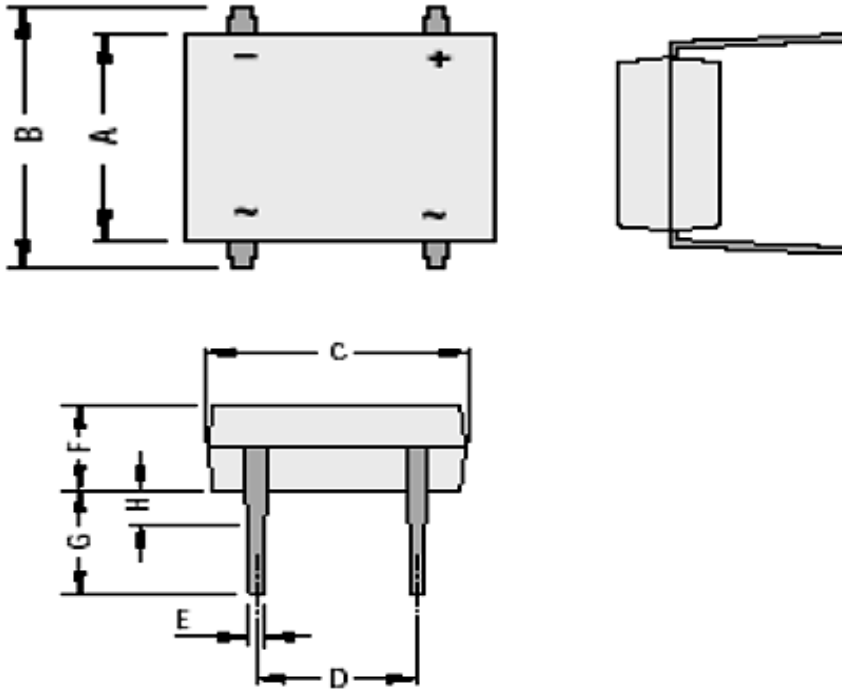

DIM	MIN	MAX
A	6.2	6.5
B	7.6	8.9
C	8.0	8.3
D	5.0	5.2
E		0.5
F	2.6	3.2
G	2.9	4.2
H		1.5

DB101\_107  
Rev01 23112020E



Continental Device India Pvt. Limited

An IATF 16949, ISO9001 and ISO 14001 Certified Company



## Recommended Product Storage Environment for Discrete Semiconductor Devices

This storage environment assumes that the Diodes and transistors are packed properly inside the original packing supplied by CDIL.

- Temperature 5 °C to 30 °C
- Humidity between 40 to 70 %RH
- Air should be clean.
- Avoid harmful gas or dust.
- Avoid outdoor exposure or storage in areas subject to rain or water spraying .
- Avoid storage in areas subject to corrosive gas or dust. Product shall not be stored in areas exposed to direct sunlight.
- Avoid rapid change of temperature.
- Avoid condensation.
- Mechanical stress such as vibration and impact shall be avoided.
- The product shall not be placed directly on the floor.
- The product shall be stored on a plane area. They should not be turned upside down. They should not be placed against the wall.

### **Shelf Life of CDIL Products**

The shelf life of products is the period from product manufacture to shipment to customers. The product can be unconditionally shipped within this period. The period is defined as 2 years.

If products are stored longer than the shelf life of 2 years the products shall be subjected to quality check as per CDIL quality procedure.

The products are further warranted for another one year after the date of shipment subject to the above conditions in CDIL original packing.

### **Floor Life of CDIL Products and MSL Level**

When the products are opened from the original packing, the floor life will start.

For this, the following JEDEC table may be referred:

JEDEC MSL Level		
Level	Time	Condition
1	Unlimited	≤30 °C / 85% RH
2	1 Year	≤30 °C / 60% RH
2a	4 Weeks	≤30 °C / 60% RH
3	168 Hours	≤30 °C / 60% RH
4	72 Hours	≤30 °C / 60% RH
5	48 Hours	≤30 °C / 60% RH
5a	24 Hours	≤30 °C / 60% RH
6	Time on Label(TOL)	≤30 °C / 60% RH



Continental Device India Pvt. Limited

An IATF 16949, ISO9001 and ISO 14001 Certified Company



## Customer Notes

### Component Disposal Instructions

1. CDIL Semiconductor Devices are RoHS compliant, customers are requested to please dispose as per prevailing Environmental Legislation of their Country.
2. In Europe, please dispose as per EU Directive 2002/96/EC on Waste Electrical and Electronic Equipment (WEEE).

### Disclaimer

The product information and the selection guides facilitate selection of the CDIL's Semiconductor Device(s) best suited for application in your product(s) as per your requirement. It is recommended that you completely review our Data Sheet(s) so as to confirm that the Device(s) meet functionality parameters for your application. The information furnished in the Data Sheet and on the CDIL Web Site/CD are believed to be accurate and reliable. CDIL however, does not assume responsibility for inaccuracies or incomplete information. Furthermore, CDIL does not assume liability whatsoever, arising out of the application or use of any CDIL product; neither does it convey any license under its patent rights nor rights of others. These products are not designed for use in life saving/support appliances or systems. CDIL customers selling these products (either as individual Semiconductor Devices or incorporated in their end products), in any life saving/support appliances or systems or applications do so at their own risk and CDIL will not be responsible for any damages resulting from such sale(s).

CDIL strives for continuous improvement and reserves the right to change the specifications of its products without prior notice.



CDIL is a registered trademark of

**Continental Device India Pvt. Limited**

C-120 Naraina Industrial Area, New Delhi 110 028, India.

Telephone +91-11-2579 6150, 4141 1112 Fax +91-11-2579 5290, 4141 1119

email@cdil.com www.cdil.com

CIN No. U32109DL1964PTC004291

DB101\_107

Rev01 23112020E