



# Dual Channel Power Driver

## FEATURES

- Two independent Drivers
- 1.5A Totem Pole Outputs
- Inverting and Non-Inverting Inputs
- 40ns Rise and Fall into 1000pF
- High-Speed, Power MOSFET Compatible
- Low Cross-Conduction Current Spike
- Analog Shutdown with Optional Latch
- Low Quiescent Current
- 5V to 40V Operation
- Thermal Shutdown Protection
- 16-Pin Dual-In-Line Package
- 20-Pin PLCC and CLCC Package

## DESCRIPTION

The UC1707 family of power drivers is made with a high-speed Schottky process to interface between low-level control functions and high-power switching devices - particularly power MOSFETs. These devices contain two independent channels, each of which can be activated by either a high or low input logic level signal. Each output can source or sink up to 1.5A as long as power dissipation limits are not exceeded.

Although each output can be activated independently with its own inputs, it can be forced low in common through the action either of a digital high signal at the Shutdown terminal or a differential low-level analog signal. The Shutdown command from either source can either be latching or not, depending on the status of the Latch Disable pin.

Supply voltage for both VIN and VC can independently range from 5V to 40V.

These devices are available in two-watt plastic "bat-wing" DIP for operation over a 0°C to 70°C temperature range and, with reduced power, in a hermetically sealed cerdip for -55°C to +125°C operation. Also available in surface mount DW, Q, L packages.

## TRUTH TABLE (Each Channel)

INV.	N.I.	OUT
H	H	L
L	H	H
H	L	L
L	L	L

$OUT = \overline{INV}$  and N.I.  
 $\overline{OUT} = INV$  or N.I.

## BLOCK DIAGRAM

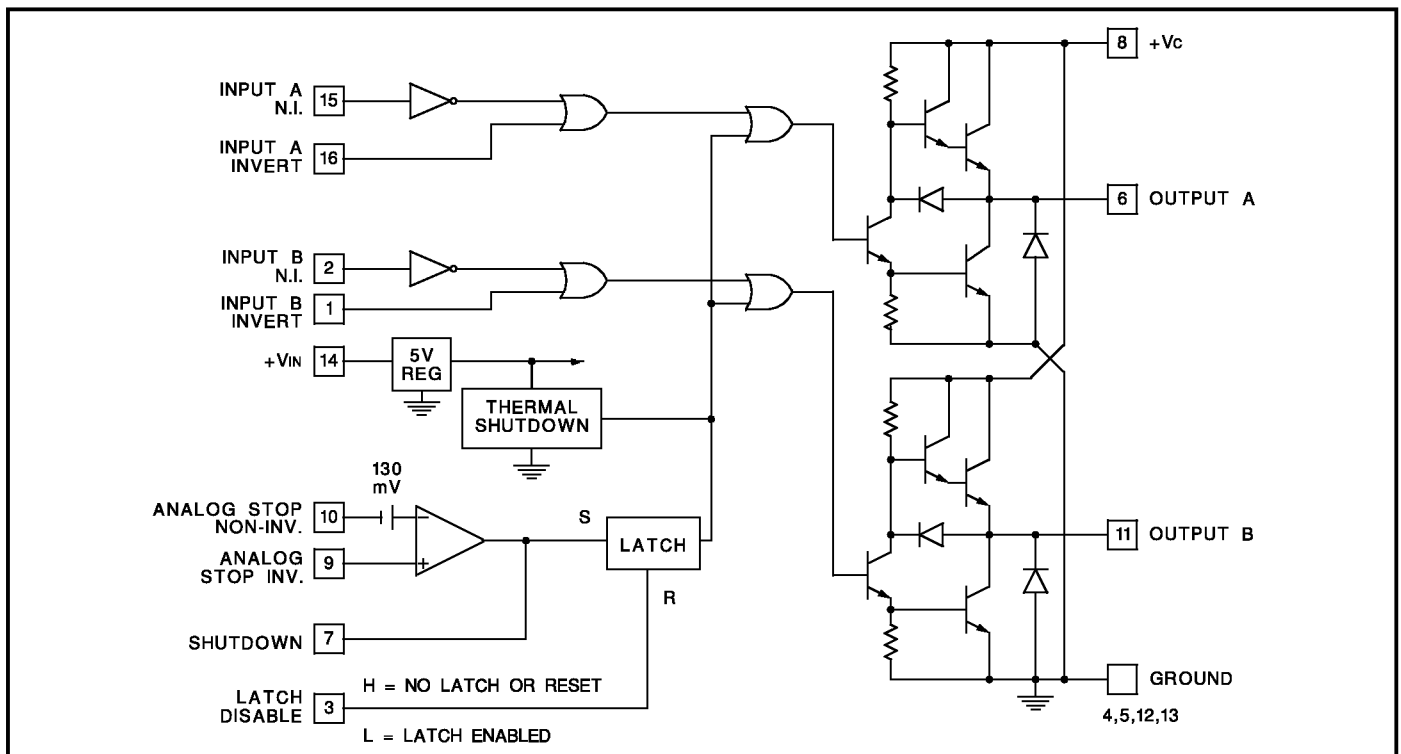

**ABSOLUTE MAXIMUM RATINGS**

Supply Voltage, VIN, N/J-Pkg	40V
Collector Supply Voltage, VC, N/J-Pkg	40V
Output Current (Each Output, Source or Sink) Steady-State, N/J-Pkg	±500mA
Peak Transient	
N-Pkg	±1.5A
J-Pkg	±1.0A
Capacitive Discharge Energy	
N-Pkg	20mJ
J-Pkg	15mJ
Digital Inputs (See Note), N/J-Pkg	5.5V
Analog Stop Inputs, N/J-Pkg	VIN
Power Dissipation at TA = 25°C (See Note)	
N-Pkg	2W
J-Pkg	1W
Power Dissipation at T (Leads/Case) = 25°C (See Note)	
N-Pkg	5W
J-Pkg	2W
Operating Temperature Range	-55°C to +125°C
Storage Temperature Range	-65°C to +150°C
Lead Temperature (Soldering, 10 Seconds)	300°C

*Note: All voltages are with respect to the four ground pins which must be connected together. All currents are positive into, negative out of the specified terminal. Digital Drive can exceed 5.5V if input current is limited to 10mA. Consult Packaging section of Databook for thermal limitations and considerations of package.*

**CONNECTION DIAGRAMS**

**DIL-16, SOIC-16 (TOP VIEW)  
J or N Package,**

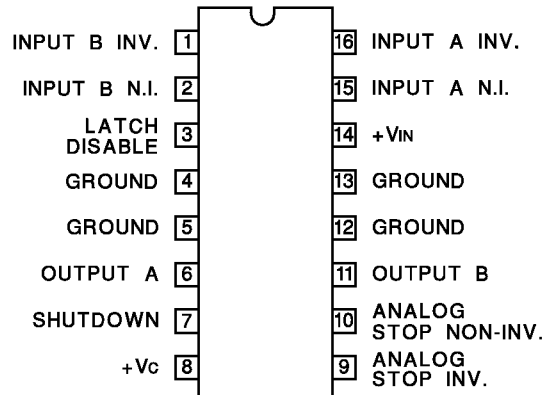

*Note: All four ground pins must be connected to a common ground.*

**PLCC-20, LCC-20 (TOP VIEW)  
Q, L Packages**

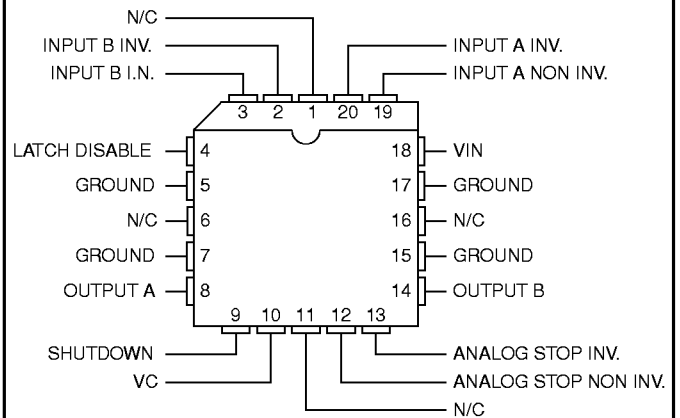

**ELECTRICAL CHARACTERISTICS:** Unless otherwise stated, these specifications apply for  $T_A = -55^\circ\text{C}$  to  $+125^\circ\text{C}$  for the UC1707,  $-25^\circ\text{C}$  to  $+85^\circ\text{C}$  for the UC2707 and  $0^\circ\text{C}$  to  $+70^\circ\text{C}$  for the UC3707;  $V_{IN} = V_C = 20\text{V}$ .  $T_A = T_J$ .

PARAMETERS	TEST CONDITIONS	MIN	TYP	MAX	UNITS
$V_{IN}$ Supply Current	$V_{IN} = 40\text{V}$		12	15	mA
$V_C$ Supply Current	$V_C = 40\text{V}$ , Outputs Low		5.2	7.5	mA
$V_C$ Leakage Current	$V_{IN} = 0$ , $V_C = 30\text{V}$ , No Load		.05	0.1	mA
Digital Input Low Level				0.8	V
Digital Input High Level		2.2			V
Input Current	$V_I = 0$		-0.06	-1.0	mA
Input Leakage	$V_I = 5\text{V}$		.05	0.1	mA
Output High Sat., $V_C - V_O$	$I_O = -50\text{mA}$			2.0	V
	$I_O = -500\text{mA}$			2.5	V
Output Low Sat., $V_O$	$I_O = -50\text{mA}$			0.4	V
	$I_O = -500\text{mA}$			2.5	V
Analog Threshold	$V_{CM} = 0$ to $15\text{V}$	100	130	160	mV
Input Bias Current	$V_{CM} = 0$		-10	-20	$\mu\text{A}$
Thermal Shutdown			155		$^\circ\text{C}$
Shutdown Threshold	Pin 7 Input	0.4	1.0	2.2	V
Latch Disable Threshold	Pin 3 Input	0.8	1.2	2.2	V

**TYPICAL SWITCHING CHARACTERISTICS:**  $V_{IN} = V_C = 20\text{V}$ ,  $T_A = 25^\circ\text{C}$ . Delays measured to 10% output change.

PARAMETERS	TEST CONDITIONS	OUTPUT CL =			UNITS
<b>From Inv. Input to Output</b>		open	1.0	2.2	nF
Rise Time Delay		40	50	60	ns
10% to 90% Rise		25	40	50	ns
Fall Time Delay		30	40	50	ns
90% to 10% Fall		25	40	50	ns
<b>From N.I. Input to Output</b>					
Rise Time Delay		30	40	50	ns
10% to 90% Rise		25	40	50	ns
Fall Time Delay		45	55	65	ns
90% to 10% Fall		25	40	50	ns
$V_C$ Cross-Conduction Current Spike Duration	Output Rise	25			ns
	Output Fall	0			ns
Analog Shutdown Delay	Stop non-Inv. = $0\text{V}$	180			ns
	Stop Inv. = $0$ to $0.5\text{V}$	180			ns
Digital Shutdown Delay	$2\text{V}$ Input on Pin 7	50			ns

**SIMPLIFIED INTERNAL CIRCUITRY**

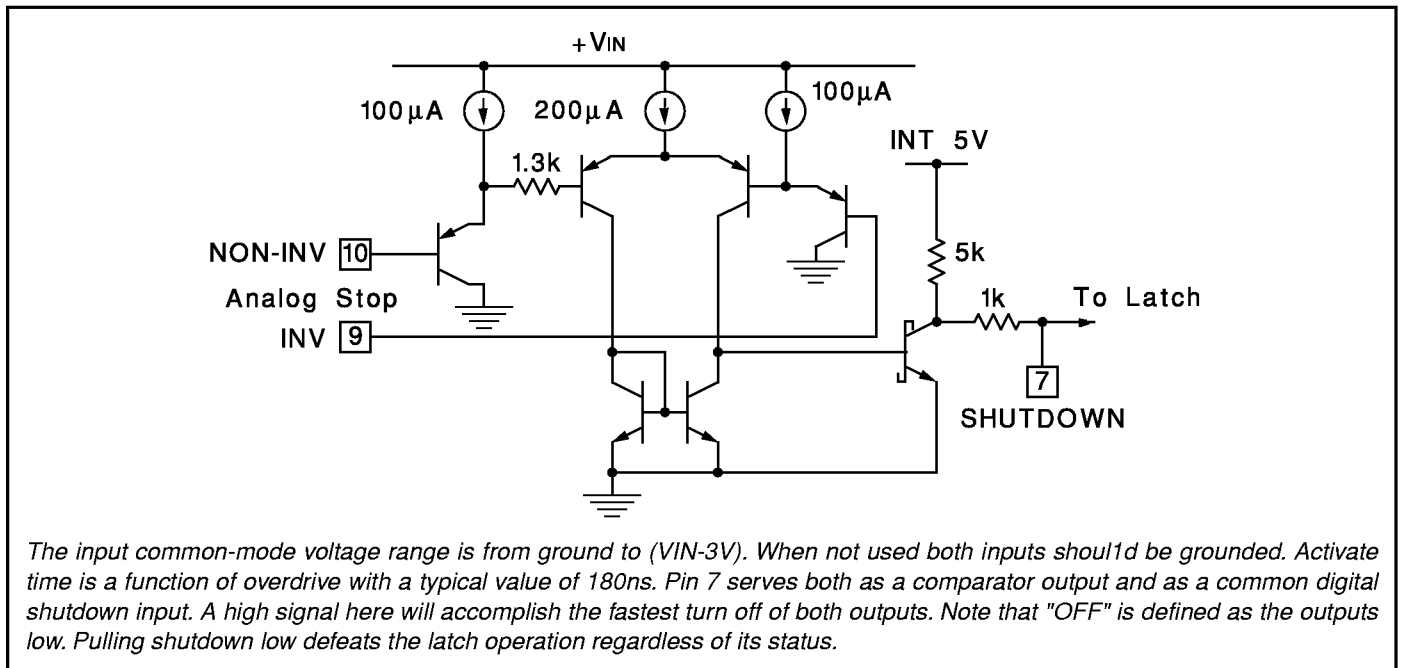

**Figure 1. Typical digital input gate.**

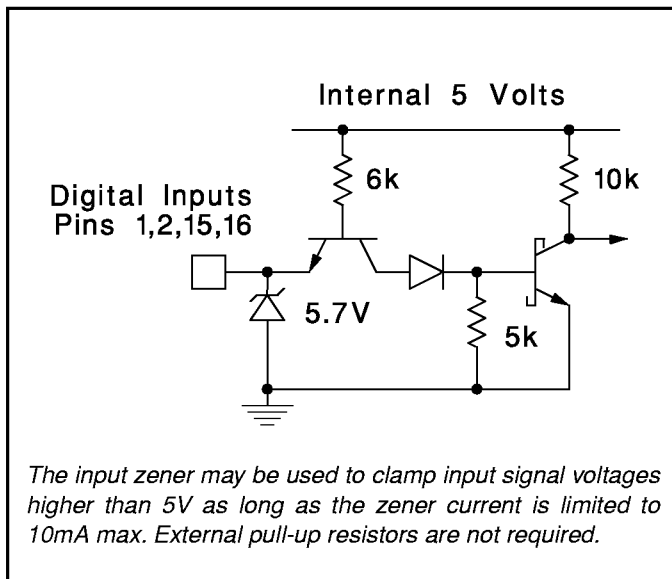

**Figure 2. Typical digital input gate.**

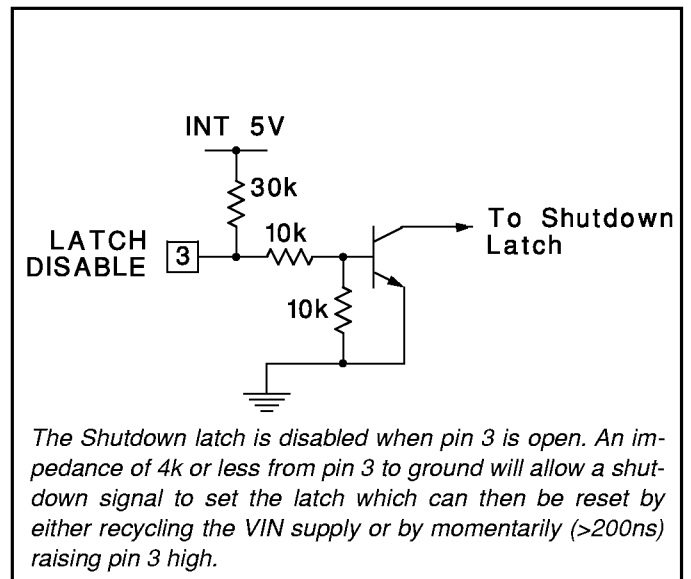

**Figure 3. Latch disable.**

SIMPLIFIED INTERNAL CIRCUITRY (cont.)

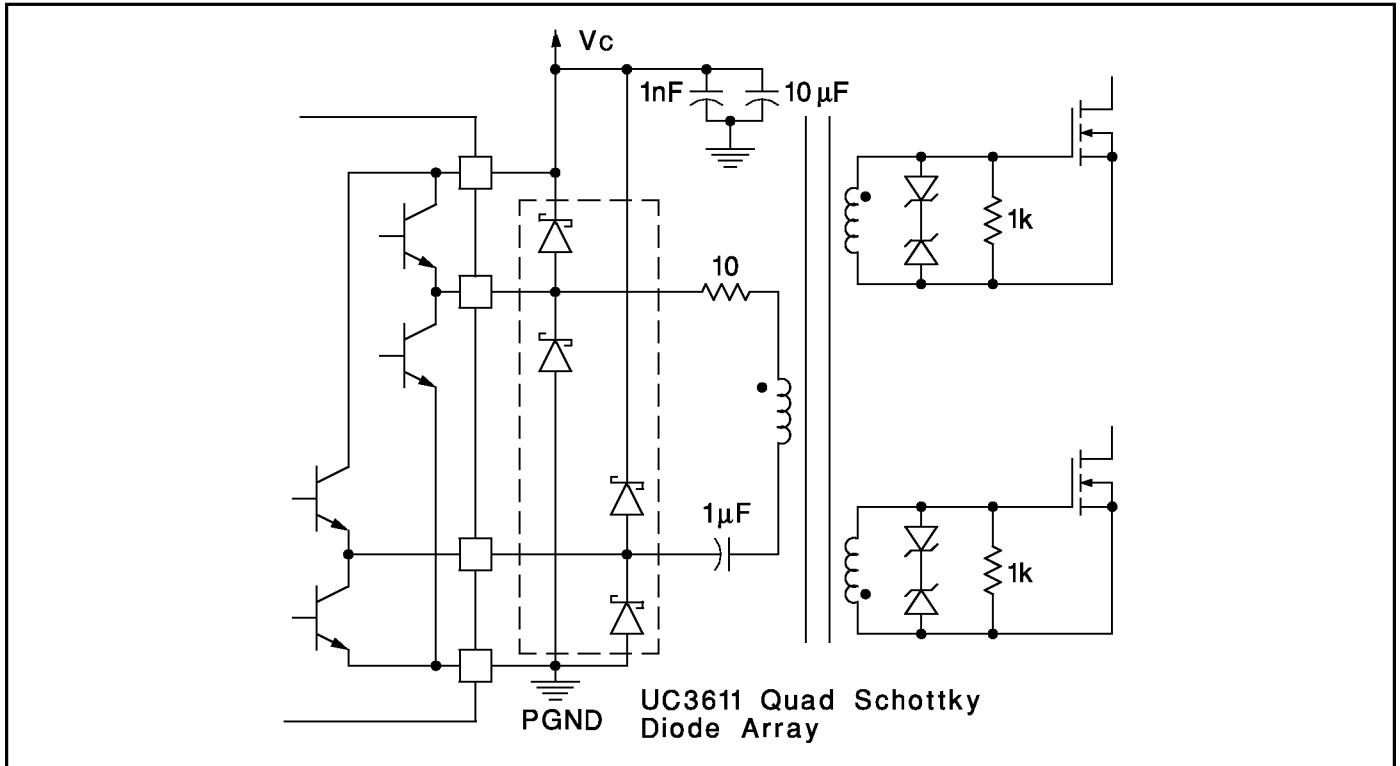
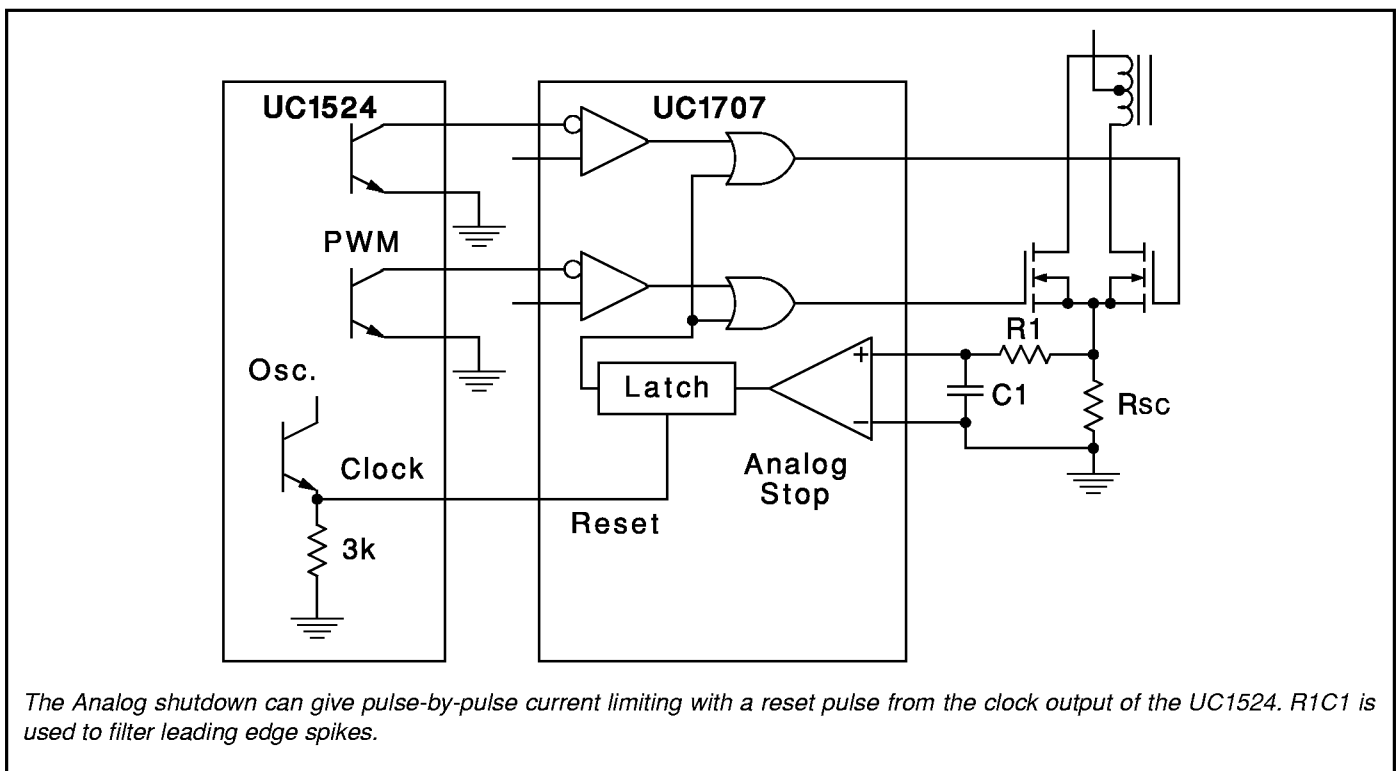

Figure 4. Transformer coupled push-pull MOSFET drive circuit.



The Analog shutdown can give pulse-by-pulse current limiting with a reset pulse from the clock output of the UC1524. R1C1 is used to filter leading edge spikes.

Figure 5. Current limiting.

APPLICATIONS

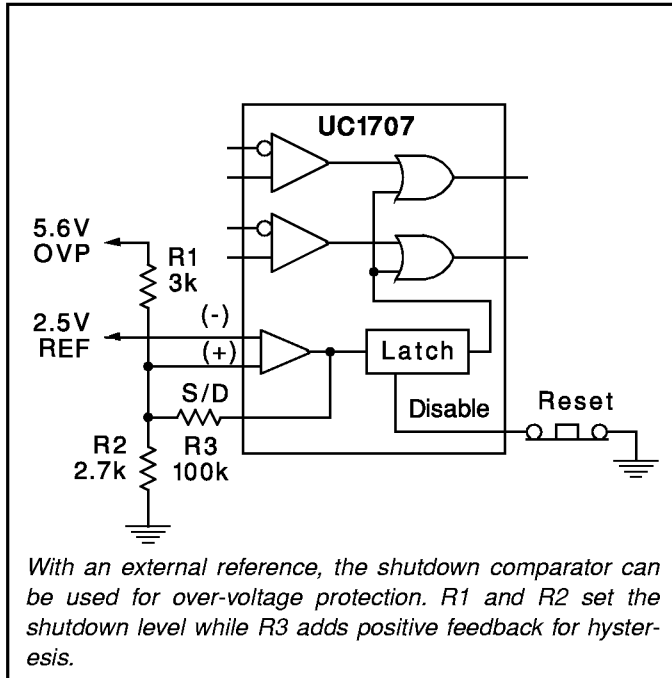

Figure 6. Over-voltage protection.

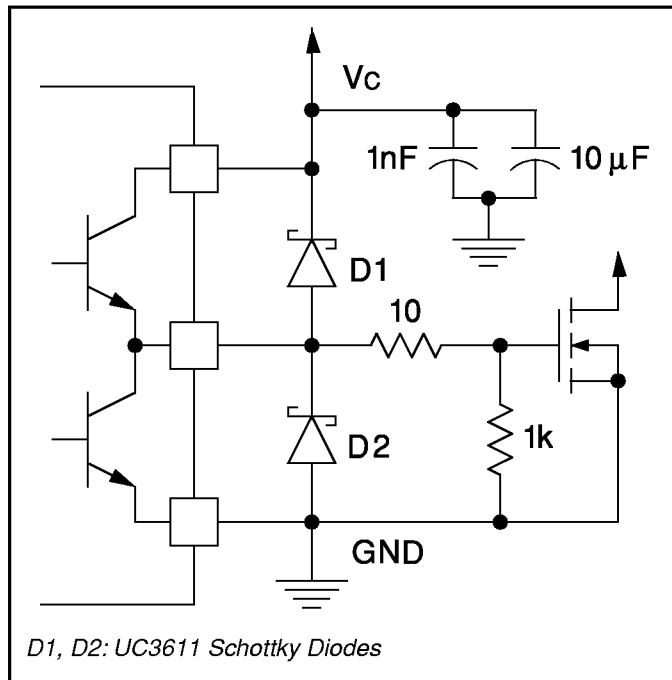

Figure 7. Power MOSFET drive circuit.

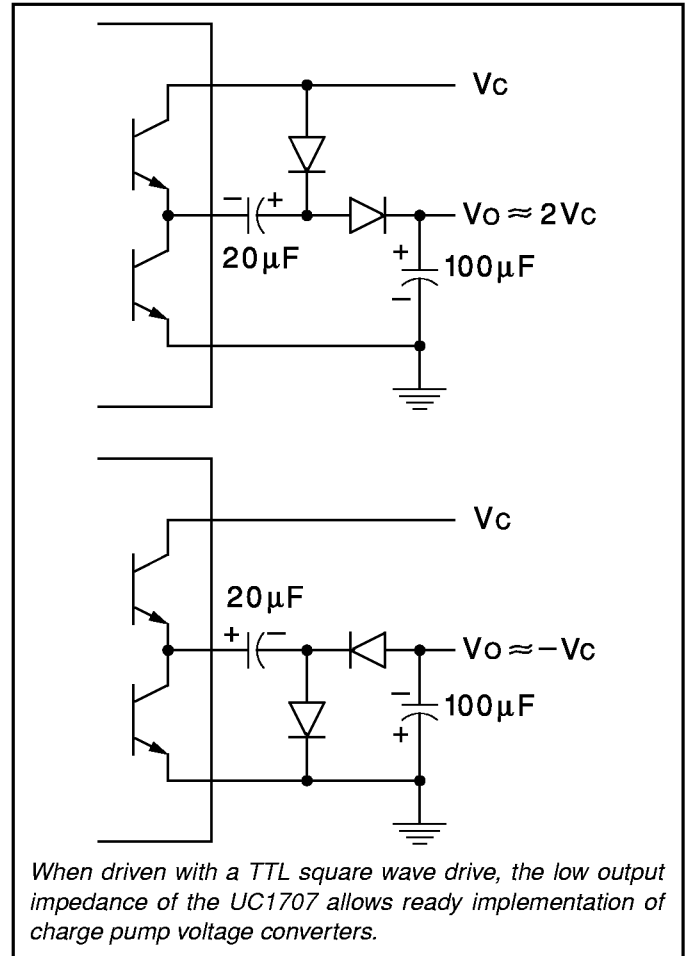

Figure 8. Charge pump circuits.

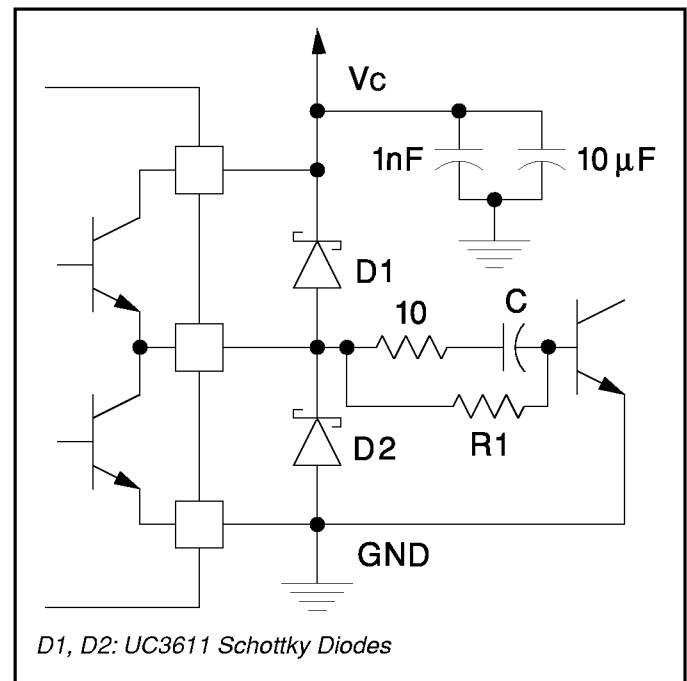

Figure 9. Power bipolar drive circuit.

TRANSFORMER COUPLING

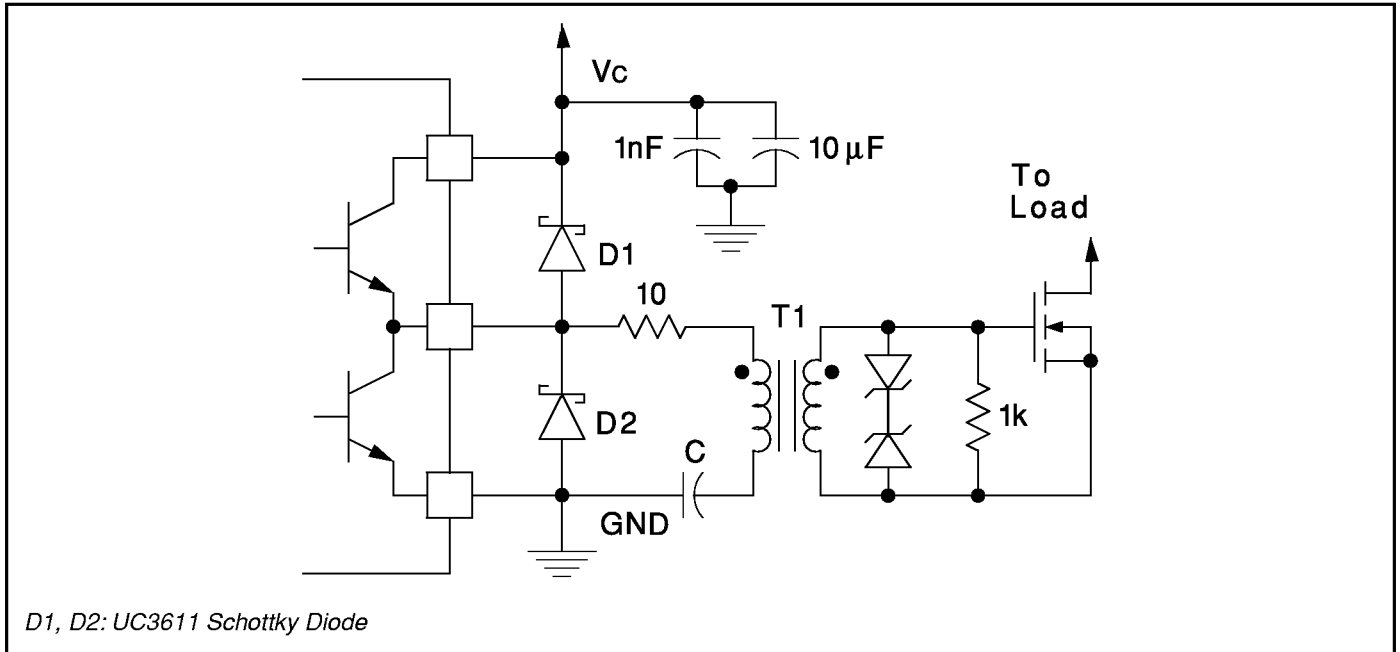

Figure 10. Transformer coupled MOSFET drive circuit.

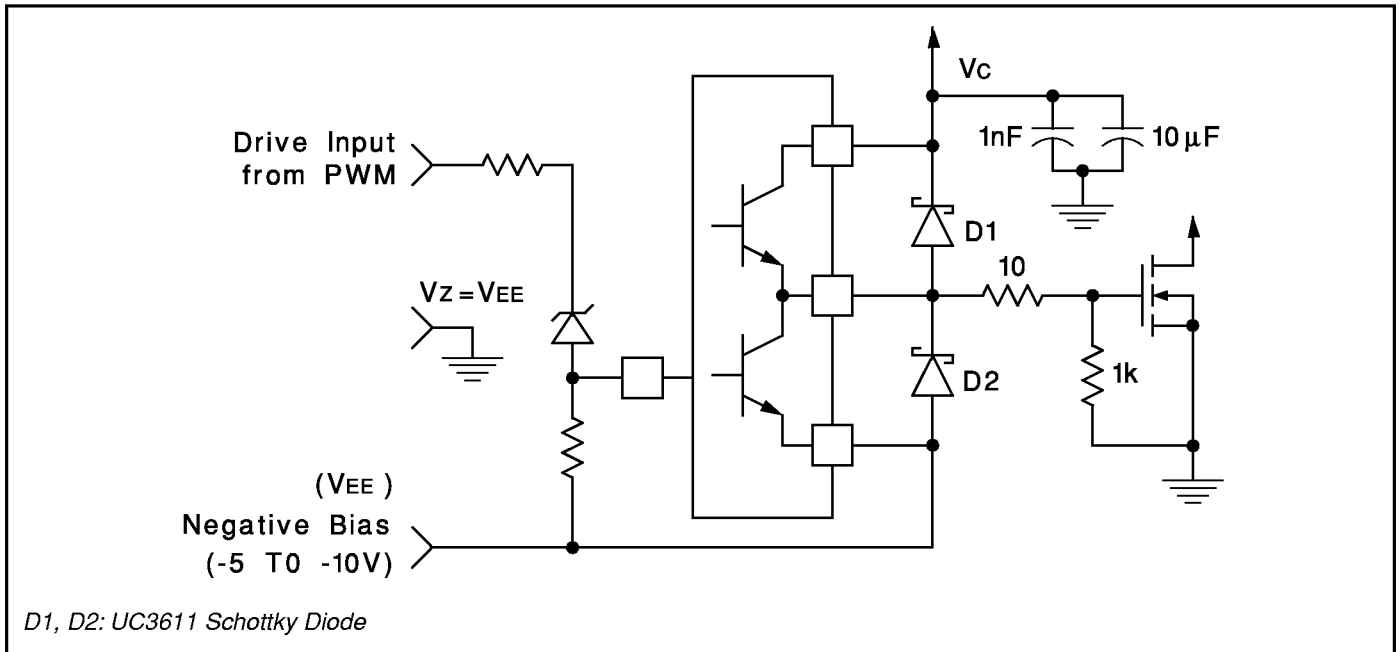

Figure 11. Power MOSFET drive circuit using negative bias voltage and level shifting to ground reference PWM.