

Helping Customers Innovate, Improve & Grow

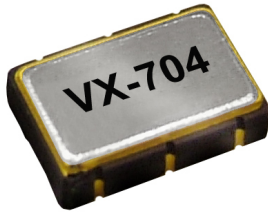

VX-704

### Features

- 5x7 Surface Mount Package
- Reflow Process Compatible Optional
- AC MOS, TTL and LVPECL
- Frequency Range: 1 MHz to 800 MHz
- Previous Model: C5250, MC025, MC031, MC034, and MC035

### Applications

- Base Stations
- Test Equipment
- Telecom & Wireless Infrastructure
- Digital Switching

### Performance Specifications

Parameter	Min	Typ	Max	Units	Condition
<b>Frequency Stabilities<sup>1</sup></b>					
vs. operating temperature range (referenced to +25°C)					-40... +85°C 0... +70°C
vs. supply voltage change	-2		+2	ppm	Vs ± 5%
vs. load change	-1		+1	ppm	Load ± 10%
vs. aging / 1 year	-5	±3	+5	ppm	
vs. aging / year (following years)	-1		+1	ppm	
<b>Supply Voltage (Vs)</b>					
Supply voltage	4.75	5.0	5.25	VDC	
Current consumption			15 20 40 100	mA mA mA mA	ACMOS/TTL 1.0 to 23.9 MHz ACMOS/TTL 24 to 49.9 MHz ACMOS/TTL 50 to 80.0 MHz LVPECL No load
Supply voltage	3.135	3.3	3.465	VDC	
Current consumption (No Load)			6 8 12 16 60 100	mA mA mA mA mA mA	ACMOS 1.0 to 14.90 MHz ACMOS 15.0 TO 39.9 MHz ACMOS 40.0 TO 59.9 MHz ACMOS 60.0 TO 79.9 MHz ACMOS 80.0 to 125.0 MHz LVPECL

## Performance Specifications

Parameter	Min	Typ	Max	Units	Condition
<b>RF Output</b>					
<b>Signal</b>	<b>ACMOS</b>				
Load		15	50	pF	
Signal Level (Vol)			0.5 0.3	VDC VDC	with Vs=5.0V and 15pF load with Vs=3.3V and 15pF load
Signal Level (Voh)	4.5 3.0			VDC VDC	with Vs=5.0V and 15pF load with Vs=3.3V and 15pF load
Rise and fall times for ACMOS (measured 10% to 90%)			10 5 3	ns ns ns	1.0 to 23.9 MHz 24.0 to 79.9 MHz 80.0 to 125.0MHz
Duty cycle	45 40		55 60	% %	@ 50% Vs < 15 MHz @ 50% Vs >= 15 MHz
<b>Signal</b>	<b>TTL</b>				
Load			10	pF	
Signal Level (Vol)			0.5	VDC VDC	with Vs=5.0V and 15pF load
Signal Level (Voh)	4.5			VDC VDC	with Vs=5.0V and 15pF load
Rise and fall times for TTL (measured 10% to 90%)			5 3	ns ns	1.0 to 23.9 MHz 24.0 to 125 MHz
Duty cycle	45 40		55 60	% %	@ 1.4V < 15 MHz @ 1.4V >= 15 MHz
<b>Signal</b>	<b>PECL/LVPECL</b>				
Load			50	ohm	Into Vs-2V or There in Equivalent
Signal Level (Vol)			Vs-1.62	VDC	
Signal Level (Voh)	Vs-1.025			VDC	
Rise and fall times for ACMOS (measured 20% to 80%)			1000 600	ps ps	< 100 MHz >= 100 MHz
Duty cycle	45 40		55 60	% %	@ 50% Vdd @ 50% Vdd
Startup Time			10	ms	
Jitter (rms)			5 1	ps ps	BW = 10Hz to 20 MHz BW = 12 kHz to 20 MHz
Period Jitter (pk-pk)			40	ps	10,000 samples- Rising edge
<b>Frequency Tuning (EFC)</b>					
Absolute Pull Range		±30 ±50		ppm ppm	Relative to nominal frequency
Linearity		10	15	%	
Tuning Slope	Positive				
Control Voltage Range	0.5 0.3	2.5 1.65	4.5 3.0	VDC VDC	with Vs=5.0V with Vs=3.3V
<b>Additional Parameters</b>					
Phase Noise (Measured @ 52.00 MHz)			-60 -90 -120 -140 -145	dBc/Hz dBc/Hz dBc/Hz dBc/Hz dBc/Hz	10 Hz 100 Hz 1 KHz 10 KHz 100 KHz

## Performance Specifications

Parameter	Min	Typ	Max	Units	Condition
Phase Noise (Measured @ 155.52 MHz)			-50	dBc/Hz	10 Hz
			-80	dBc/Hz	100 Hz
			-110	dBc/Hz	1 KHz
			-133	dBc/Hz	10 KHz
			-145	dBc/Hz	100 KHz
Output Enable	Logic "0" input = Outputs disabled (Tri-state) Logic "1" or floating input = Outputs enabled				ACMOS/TTL Output
	Logic "0" input = Outputs enabled Logic "1" or floating input = Outputs disabled (Tri-state)				PECL/LVPECL Output
Weight			<2	g	
Processing & Packing	Handling & processing note				
Absolute Maximum Ratings					
Supply voltage (Vs)			7	V	with Vs=5.0 VDC
			4.6	V	with Vs=3.3 VDC
Operable temperature range	-45		+85	°C	
Storage temperature range	-55		+125	°C	

## Outline Drawing / Enclosure

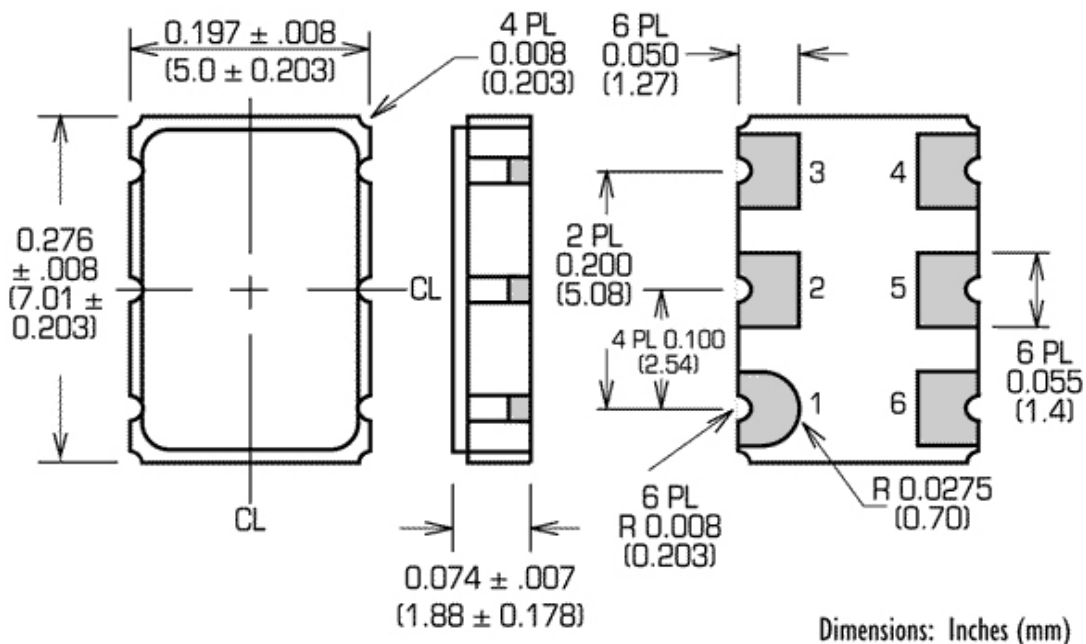

Type B		
Code	Height "H"	Pin Length
0	1.88mm	NA

Pin Connections	
1	VCXO input
2	Enable/Disable or N/C
3	Ground (Case)
4	RF Output
5	Complementary Output or N/C
6	Supply Voltage

## Ordering Information

**VX - 704 0 - D A T - K X X X - 10M0000000**

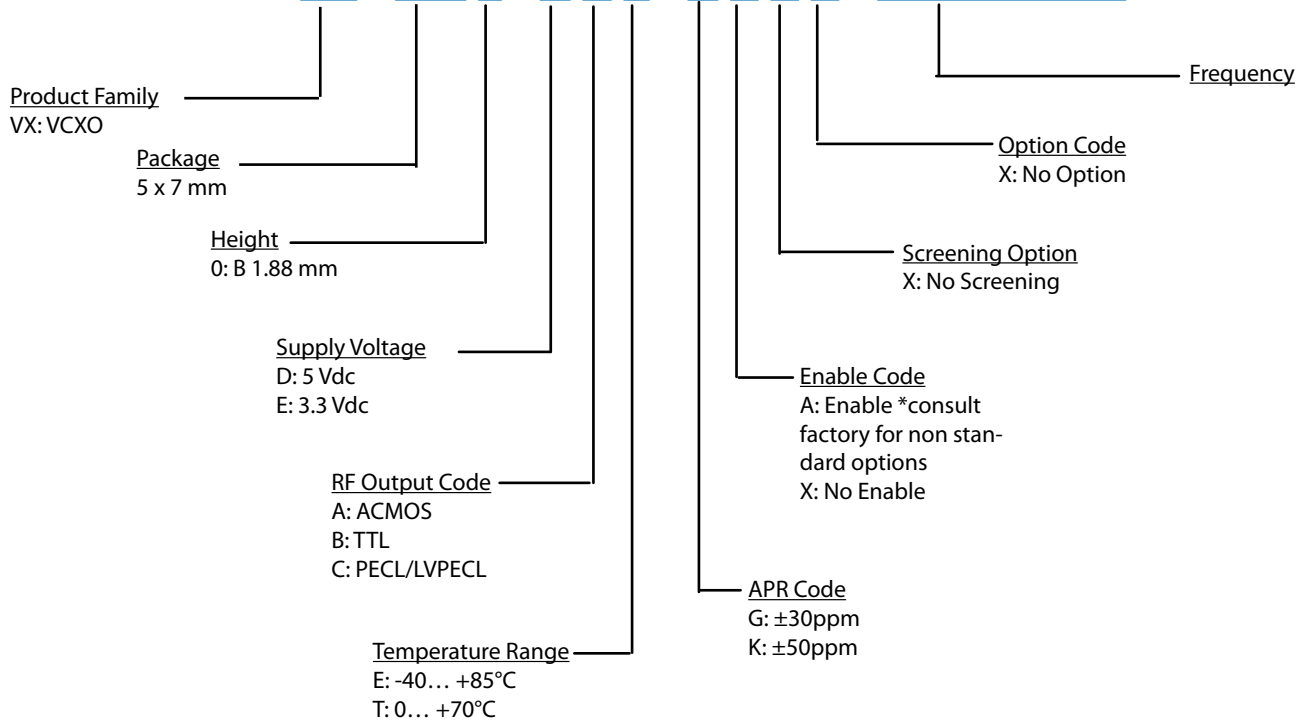

**Notes:**

1. Contact factory for improved stabilities or additional product options. Not all options and codes are available at all frequencies.
2. Unless other stated all values are valid after warm-up time and refer to typical conditions for supply voltage, frequency control voltage, load, temperature (25°C).
3. Phase noise degrades with increasing output frequency.
4. Subject to technical modification.

## For Additional Information, Please Contact

**USA:**

Vectron International  
267 Lowell Road, Unit 102  
Hudson, NH 03051  
Tel: 1.888.328.7661  
Fax: 1.888.329.8328

**Europe:**

Vectron International  
Landstrasse, D-74924  
Neckarbischofsheim, Germany  
Tel: +49 (0) 3328.4784.17  
Fax: +49 (0) 3328.4784.30

**Asia:**

Vectron International  
68 Yin Cheng Road(C), 22nd Floor  
One LuJiaZui  
Pudong, Shanghai 200120, China  
Tel: 86.21.6194.6886  
Fax: 86.21.6194.6699

**Disclaimer**

Vectron International reserves the right to make changes to the product(s) and or information contained herein without notice. No liability is assumed as a result of their use or application. No rights under any patent accompany the sale of any such product(s) or information.

Rev: 1/6/2015 JV