

SN54HC679, SN54HC680, SN74HC679, SN74HC680 12-BIT ADDRESS COMPARATORS

D2833, MARCH 1984—REVISED SEPTEMBER 1987

- 'HC679 is a 12-Bit Address Comparator With Enable
- 'HC680 is a 12-Bit Address Comparator With Latch
- Package Options Include Plastic "Small Outline" Packages, Ceramic Chip Carriers, and Standard Plastic and Ceramic 300-mil DIPs
- Dependable Texas Instruments Quality and Reliability

description

The 'HC679 and 'HC680 address comparators simplify addressing of memory boards and/or other peripheral devices. The four P inputs are normally hard wired with a preprogrammed address. An internal decoder determines what input information applied to the 12 A inputs must be low or high to cause a low state at the output (Y). For example, a positive-logic bit combination of 0111 (decimal 7) at the P input determines that inputs A1 through A7 must be low and that inputs A8 through A12 must be high to cause the output to go low. Equality of the address applied at the A inputs to the preprogrammed address is indicated by the output being low.

The 'HC679 features an enable input (\bar{G}). When \bar{G} is low, the device is enabled. When \bar{G} is high, the device is disabled and the output is high regardless of the A and P inputs. The 'HC680 features a transparent latch and a latch enable input (C). When C is high, the device is in the transparent mode. When C is low, the previous logical state of Y is latched.

The 'HC679 and 'HC680 are functionally unilaterally interchangeable with their TTL ALS counterparts, 'ALS679 and 'ALS680, in all cases of normal use as 12-bit address comparators. They differ in two respects. First, they may be programmed to recognize all A inputs low either by connecting all P inputs high (1111 = decimal 15), or by combination HLLL (1100 = 12), the latter option not being valid for the TTL ALS parts. Second, the combinations HHLH and HHLL (1101 = 13 and 1110 = 14) cannot be used (but are not needed) in address-comparator applications. These two combinations cause the outputs to be disabled (high).

SN54HC679 . . . J PACKAGE
SN74HC679 . . . DW OR N PACKAGE

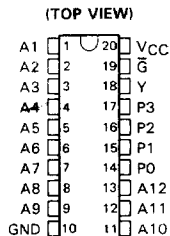

SN54HC679 . . . FK PACKAGE

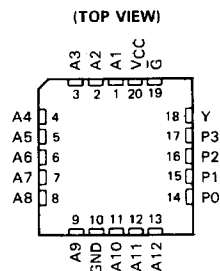

SN54HC680 . . . J PACKAGE
SN74HC680 . . . DW OR N PACKAGE

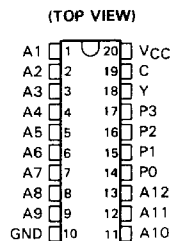

SN54HC680 . . . FK PACKAGE

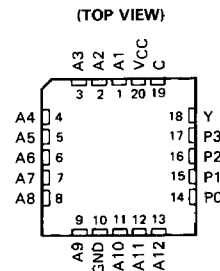

2

HCMOS Devices

SN54HC679, SN74HC679 12-BIT ADDRESS COMPARATORS

'HC679 logic diagram (positive logic)

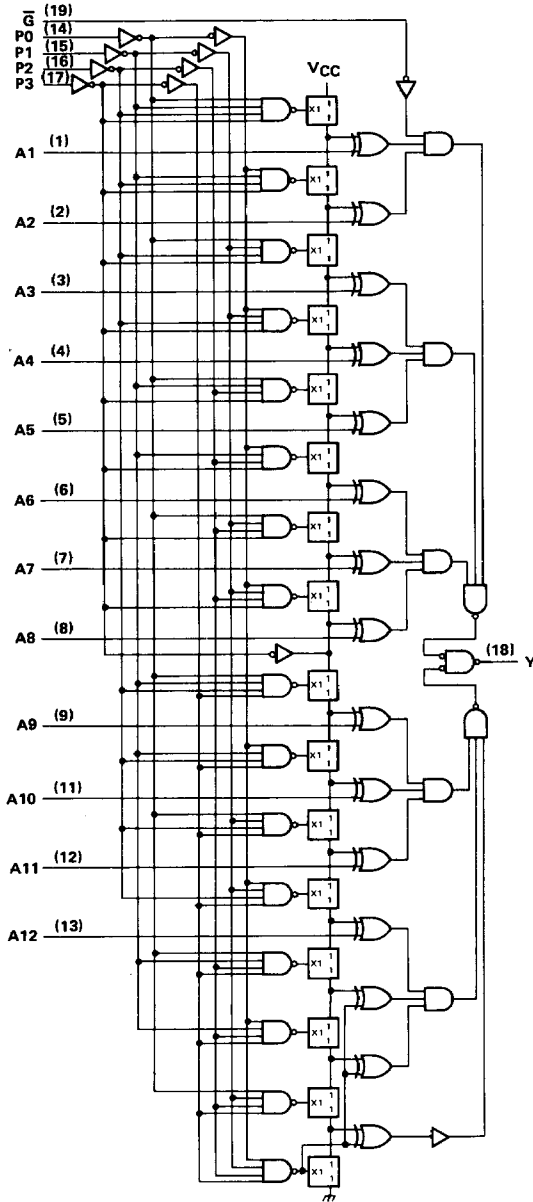

In order to understand the implementation of this device, it is essential that the function of the vertical string of transmission gates be understood. A schematic of one of these gates is shown below. If the input to the transmission gate labeled "X1" is high, then the transmission path between the two ports labeled "1" is on. If the "X1" input is low, then the transmission path between the two ports labeled "1" is off. Only one of the 16 transmission gates can be off while the device is operating; which one is off is determined by inputs P0 through P3. The lines going from the string of transmission gates to the Exclusive-OR gates located above the transmission gate that is off will be high. The lines going to the Exclusive-OR gates located below that transmission gate will be low.

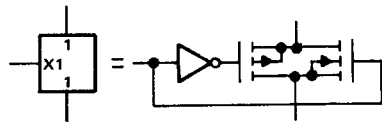

Pin numbers shown are for DW, J, and N packages.

SN54HC680, SN74HC680
12-BIT ADDRESS COMPARATORS

'HC680 logic diagram (positive logic)

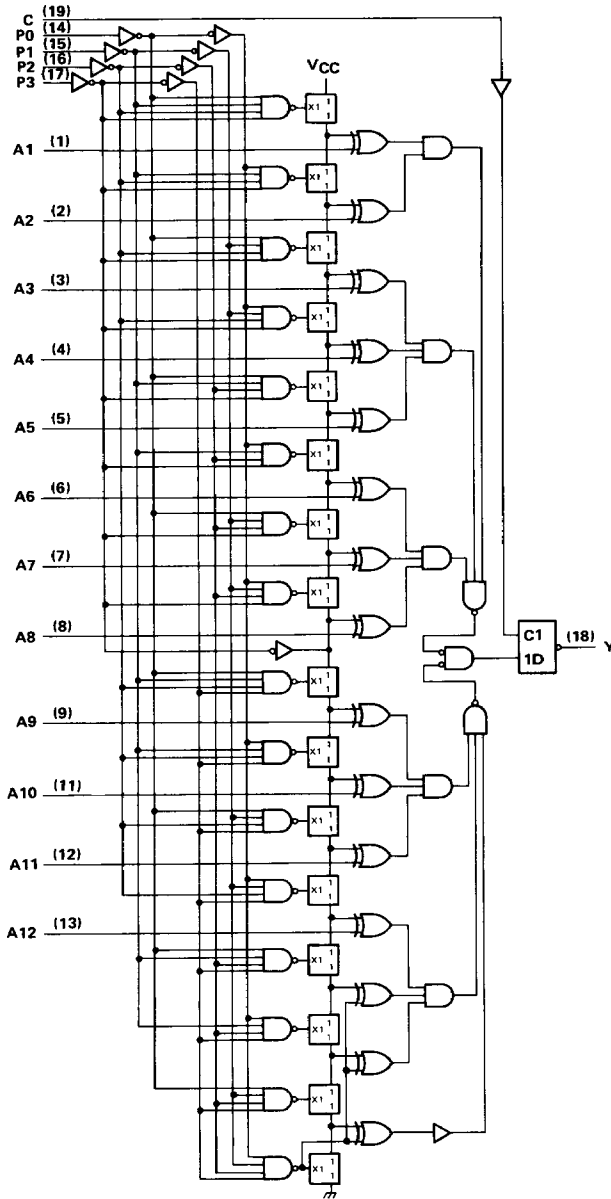

An explanation of the function of the string of transmission gates appears with the 'HC679 logic diagram on the previous page.

2 HCMOS Devices

Pin numbers shown are for DW, J, and N packages.

SN54HC679, SN74HC680, SN74HC679, SN74HC680
12-BIT ADDRESS COMPARATORS

absolute maximum ratings over operating free-air temperature range†

Supply voltage, V_{CC}	-0.5 V to 7 V
Input clamp current, I_{IK} ($V_I < 0$ or $V_I > V_{CC}$)	± 20 mA
Output clamp current, I_{OK} ($V_O < 0$ or $V_O > V_{CC}$)	± 20 mA
Continuous output current, I_O ($V_O = 0$ to V_{CC})	± 25 mA
Continuous current through V_{CC} or GND pins	± 50 mA
Lead temperature 1,6 mm (1/16 in) from case for 60 s: FK or J package	300°C
Lead temperature 1,6 mm (1/16 in) from case for 10 s: DW or N package	260°C
Storage temperature range	-65°C to 150°C

† Stresses beyond those listed under "absolute maximum ratings" may cause permanent damage to the device. These are stress ratings only, and functional operation of the device at these or any other conditions beyond those indicated under "recommended operating conditions" is not implied. Exposure to absolute-maximum-rated conditions for extended periods may affect device reliability.

recommended operating conditions

		SN54HC679 SN54HC680			SN74HC679 SN74HC680			UNIT
		MIN	NOM	MAX	MIN	NOM	MAX	
V_{CC} Supply voltage		2	5	6	2	5	6	V
V_{IH} High-level input voltage	$V_{CC} = 2$ V	1.5			1.5			V
	$V_{CC} = 4.5$ V	3.15			3.15			
	$V_{CC} = 6$ V	4.2			4.2			
V_{IL} Low-level input voltage	$V_{CC} = 2$ V	0	0.3		0	0.3		V
	$V_{CC} = 4.5$ V	0	0.9		0	0.9		
	$V_{CC} = 6$ V	0	1.2		0	1.2		
V_I Input voltage		0	V_{CC}		0	V_{CC}		V
V_O Output voltage		0	V_{CC}		0	V_{CC}		V
t_t Input transition (rise and fall) times	$V_{CC} = 2$ V	0	1000		0	1000		ns
	$V_{CC} = 4.5$ V	0	500		0	500		
	$V_{CC} = 6$ V	0	400		0	400		
T_A Operating free-air temperature		-55	125		-40	85		°C

electrical characteristics over recommended operating free-air temperature range (unless otherwise noted)

PARAMETER	TEST CONDITIONS	V_{CC}	$T_A = 25^\circ\text{C}$			SN54HC679 SN54HC680		SN74HC679 SN74HC680		UNIT
			MIN	TYP	MAX	MIN	MAX	MIN	MAX	
V_{OH}	$V_I = V_{IH}$ or V_{IL} , $I_{OH} = -20 \mu\text{A}$	2 V	1.9	1.998		1.9		1.9	V	
		4.5 V	4.4	4.499		4.4		4.4		
		6 V	5.9	5.999		5.9		5.9		
V_{OL}	$V_I = V_{IH}$ or V_{IL} , $I_{OL} = 20 \mu\text{A}$	2 V	0.002	0.1		0.1		0.1	V	
		4.5 V	0.001	0.1		0.1		0.1		
		6 V	0.001	0.1		0.1		0.1		
V_{OL}	$V_I = V_{IH}$ or V_{IL} , $I_{OL} = 4 \text{ mA}$	4.5 V	0.17	0.26		0.4		0.33	V	
		6 V	0.15	0.26		0.4		0.33		
		6 V	0.15	0.26		0.4		0.33		
I_I	$V_I = V_{CC}$ or 0	6 V	± 0.1	± 100		± 1000		± 1000	nA	
I_{CC}	$V_I = V_{CC}$ or 0, $I_O = 0$	6 V		8		160		80	μA	
C_i		2 to 6 V		3	10		10		10	pF

2
HCMOS Devices



SN54HC679, SN74HC680, SN74HC679, SN74HC680
12-BIT ADDRESS COMPARATORS

'HC679 switching characteristics over recommended operating free-air temperature range (unless otherwise noted), $C_L = 50$ pF (see Note 1)

PARAMETER	FROM (INPUT)	TO (OUTPUT)	V _{CC}	T _A = 25°C			SN54HC679		SN74HC679		UNIT
				MIN	TYP	MAX	MIN	MAX	MIN	MAX	
t _{pd}	Any P	Y	2 V		185	300	450		375		ns
			4.5 V		37	60	90		75		
			6 V		31	51	76		64		
t _{pd}	Any A	Y	2 V		105	160	240		200		ns
			4.5 V		21	32	48		40		
			6 V		18	27	41		34		
t _{pd}	\bar{G}	Y	2 V		75	125	187		156		ns
			4.5 V		15	25	37		31		
			6 V		13	21	31		26		
t _t		Y	2 V		38	60	90		75		ns
			4.5 V		8	12	18		15		
			6 V		6	10	15		13		

'HC680 timing requirements over recommended operating free-air temperature range (unless otherwise noted)

	V _{CC}	T _A = 25°C		SN54HC680		SN74HC680		UNIT
		MIN	MAX	MIN	MAX	MIN	MAX	
t _w Pulse duration, enable C high	2 V	75		112		94		ns
	4.5 V	15		23		19		
	6 V	13		20		16		
t _{su} Setup time, A inputs before enable C _I	2 V	100		150		125		ns
	4.5 V	20		30		25		
	6 V	17		26		21		
t _{su} Setup time, P inputs before enable C _I	2 V	500		750		625		ns
	4.5 V	99		149		124		
	6 V	84		127		105		
t _h Hold time, A or P inputs after enable C _I	2 V	5		5		5		ns
	4.5 V	5		5		5		
	6 V	5		5		5		

'HC680 switching characteristics over recommended operating free-air temperature range (unless otherwise noted), $C_L = 50$ pF (see Note 1)

PARAMETER	FROM (INPUT)	TO (OUTPUT)	V _{CC}	T _A = 25°C			SN54HC680		SN74HC680		UNIT
				MIN	TYP	MAX	MIN	MAX	MIN	MAX	
t _{pd}	Any P	Y	2 V		185	300	450		375		ns
			4.5 V		37	60	90		75		
			6 V		31	51	76		64		
t _{pd}	Any A	Y	2 V		105	160	240		200		ns
			4.5 V		21	32	48		40		
			6 V		18	27	41		34		
t _{pd}	C	Y	2 V		75	125	187		156		ns
			4.5 V		15	25	37		31		
			6 V		13	21	31		26		
t _t		Y	2 V		38	60	90		75		ns
			4.5 V		8	12	18		15		
			6 V		6	10	15		13		

C _{pd}	Power dissipation capacitance	No load, T _A = 25°C	40 pF typ
-----------------	-------------------------------	--------------------------------	-----------

2

HC MOS Devices

TYPICAL APPLICATION INFORMATION

The 'HC679 and 'HC680 can be wired to recognize any one of 2^{12} addresses. The number of "lows" in the address determines the input pattern for the P inputs. Then those system address lines that are low in the address to be recognized are connected to the lowest numbered A inputs of the address comparator and the system address lines that are high are connected to the highest numbered A inputs.

For example, assume the comparator is to enable a device when the 12-bit system address is:

A11	A10	A9	A8	A7	A6	A5	A4	A3	A2	A1	A0
H	H	L	L	H	H	L	L	H	H	H	H

Since the address contains 4 lows and 8 highs, the following connections are made.

P3 to 0 V, P2 to V_{CC}, P1 to 0 V, and P0 to 0 V.

System address lines A9, A8, A5, and A4 to comparator inputs A1 through A4 in any convenient order.

The remaining eight system address lines to comparator inputs A5 through A12 in any convenient order.

The output provides an active-low enabling signal.

The following circuit is a register bank decoder that examines the 14 most significant bits (A0 through A13) of a 20-bit address to select banks corresponding to the hex addresses 10000, 10040, 10080, and 100C0.

