

UT54ACS162245S

RadHard Schmitt CMOS 16-bit Bidirectional MultiPurpose Low Voltage Transceiver Datasheet

August 2006



FEATURES

- Voltage translation
 - 3.3V bus to 2.5V bus
 - 2.5V bus to 3.3V bus
- Cold sparing all pins
- 0.25 μ Commercial RadHard™ CMOS
 - Total dose: 300Krad(Si) and 1Mrad(Si)
 - Single Event Latchup immune
- High speed, low power consumption
- Schmitt trigger inputs to filter noisy signals
- Cold and Warm Spare - all outputs
- Available QML Q or V processes
- Standard Microcircuit Drawing 5962-02543
- Package:
 - 48-lead flatpack, 25 mil pitch (.390 x .640)

DESCRIPTION

The 16-bit wide UT54ACS162245S MultiPurpose low voltage transceiver is built using Aeroflex UTMC's Commercial RadHard™ epitaxial CMOS technology and is ideal for space applications. This high speed, low power UT54ACS162245S low voltage transceiver is designed to perform multiple functions including: asynchronous two-way communication, Schmitt input buffering, voltage translation, warm and cold sparing. With V_{DD} equal to zero volts, the UT54ACS162245S outputs and inputs present a minimum impedance of 1M Ω making it ideal for "cold spare" applications. Balanced outputs and low "on" output impedance make the UT54ACS162245S well suited for driving high capacitance loads and low impedance backplanes. The UT54ACS162245S enables system designers to interface 2.5 volt CMOS compatible components with 3.3 volt CMOS components. For voltage translation, the A port interfaces with the 2.5 volt bus; the B port interfaces with the 3.3 volt bus. The direction control (\overline{DIRx}) controls the direction of data flow. The output enable (\overline{OEx}) overrides the direction control and disables both ports. These signals can be driven from either port A or B. The direction and output enable controls operate these devices as either two independent 8-bit transceivers or one 16-bit transceiver.

LOGIC SYMBOL

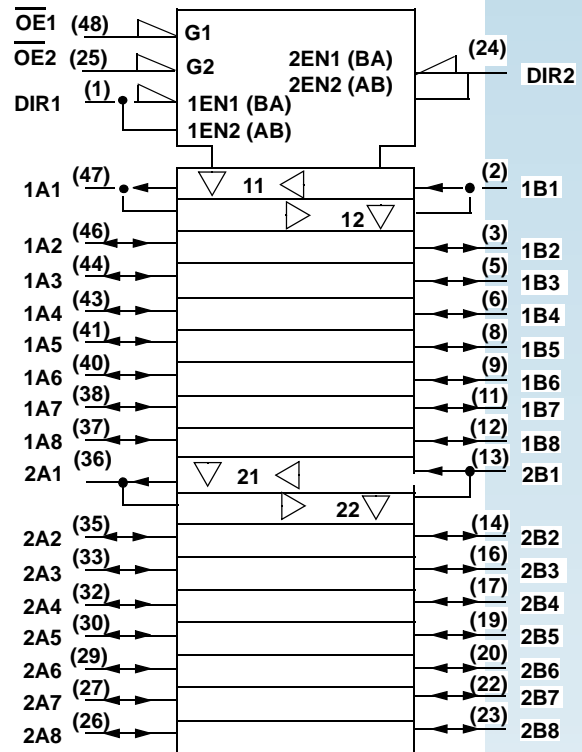

PIN DESCRIPTION

Pin Names	Description
\overline{OEx}	Output Enable Input (Active Low)
\overline{DIRx}	Direction Control Inputs
xAx	Side A Inputs or 3-State Outputs (2.5V Port)
xBx	Side B Inputs or 3-State Outputs (3.3V Port)

PINOUTS

48-Lead Flatpack Top View

DIR1	1	48	$\overline{\text{OE1}}$
1B1	2	47	1A1
1B2	3	46	1A2
V _{SS}	4	45	V _{SS}
1B3	5	44	1A3
1B4	6	43	1A4
VDD1	7	42	VDD2
1B5	8	41	1A5
1B6	9	40	1A6
V _{SS}	10	39	V _{SS}
1B7	11	38	1A7
1B8	12	37	1A8
2B1	13	36	2A1
2B2	14	35	2A2
V _{SS}	15	34	V _{SS}
2B3	16	33	2A3
2B4	17	32	2A4
VDD1	18	31	VDD2
2B5	19	30	2A5
2B6	20	29	2A6
V _{SS}	21	28	V _{SS}
2B7	22	27	2A7
2B8	23	26	2A8
DIR2	24	25	$\overline{\text{OE2}}$

When V_{DD2} is at 2.5 volts, either 2.5 or 3.3 volts CMOS logic levels can be applied to all control inputs. For proper operation connect power to all V_{DD} and ground all V_{SS} pins (i.e., no floating V_{DD} or V_{SS} input pins). Tie unused inputs to V_{SS}. Always insure V_{DD1} ≥ V_{DD2} during operation of the part.

FUNCTION TABLE

ENABLE OEx	DIRECTION DIRx	OPERATION
L	L	B Data To A Bus
L	H	A Data To B Bus
H	X	Isolation

COLD/WARM SPARE FUNCTION

The device will place all outputs into a high-impedance state if either V_{DD} supply is taken to zero volts (I_{WS}, warm spare), or if both V_{DD} supplies are set to zero volts (I_{CS}, cold spare).

DEVICE POWER UP FUNCTION

The device will place all outputs into a high-impedance during power-up. The high impedance state is maintained for a time period approximately equal to the rise time of V_{DD1}.

POWER TABLE

Port B	Port A	OPERATION
3.3 Volts	2.5 Volts	Voltage Translator
3.3 Volts	3.3 Volts	Non Translating
2.5 Volts	2.5 Volts	Non Translating

LOGIC DIAGRAM

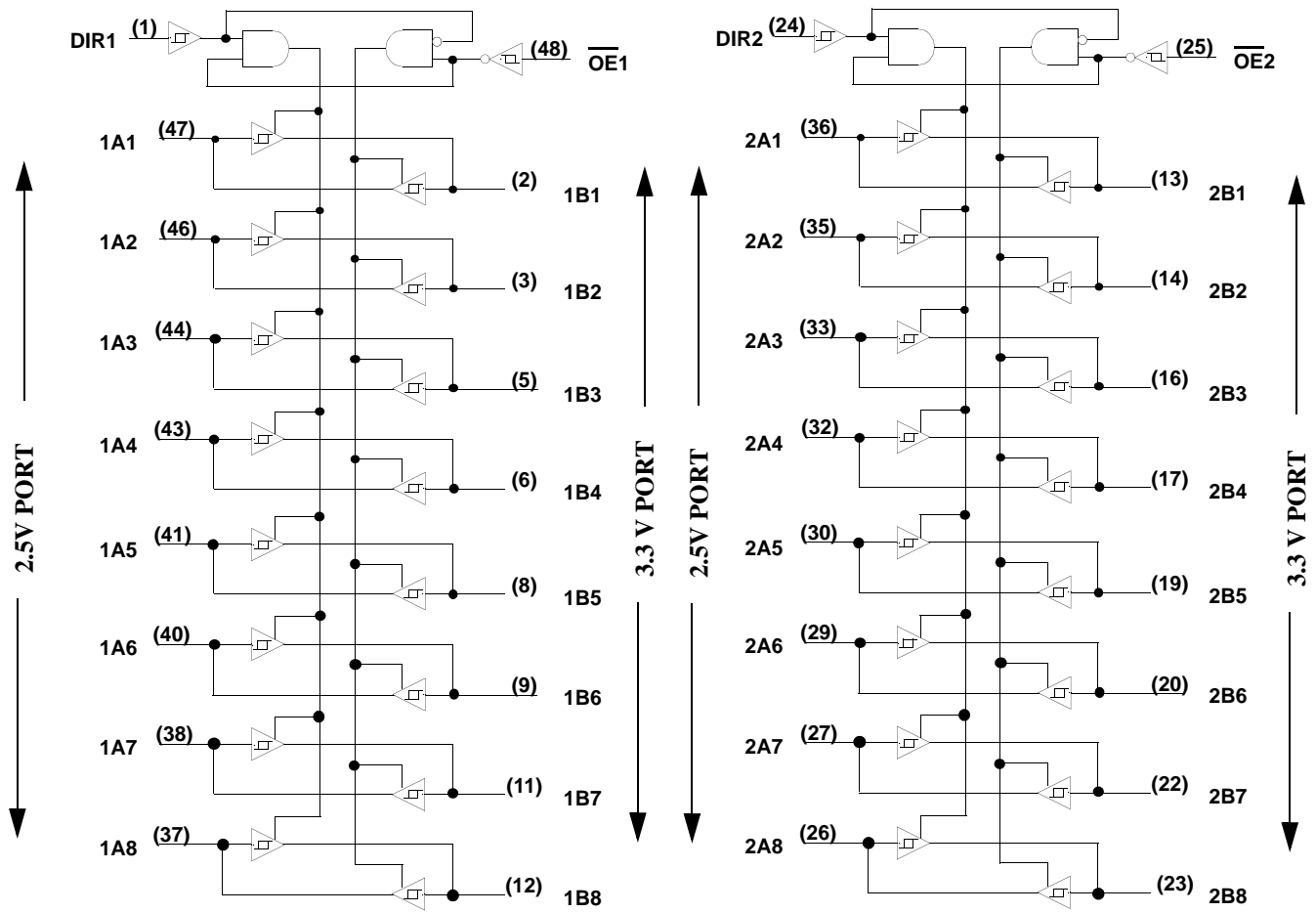

RADIATION HARDNESS SPECIFICATIONS ¹

PARAMETER	LIMIT	UNITS
Total Dose	1.0E5	rad(Si)
SEL Latchup	>113	MeV-cm ² /mg
Neutron Fluence ^(Note 2)	1.0E14	n/cm ²

Notes:

1. Logic will not latchup during radiation exposure within the limits defined in the table.
2. Not tested, inherent to CMOS technology.

ABSOLUTE MAXIMUM RATINGS¹

SYMBOL	PARAMETER	LIMIT (Mil only)	UNITS
V _{I/O} ^(Note 2)	Voltage any pin	-.3 to V _{DD1} +.3	V
V _{DD1}	Supply voltage	-0.3 to 4.0	V
V _{DD2}	Supply voltage	-0.3 to 4.0	V
T _{STG}	Storage Temperature range	-65 to +150	°C
T _J ^(Note 3)	Maximum junction temperature	+150	°C
Θ _{JC}	Thermal resistance junction to case	20	°C/W
I _I	DC input current	±10	mA
P _D	Maximum power dissipation	1	W

Note:

1. Stresses outside the listed absolute maximum ratings may cause permanent damage to the device. This is a stress rating only, functional operation of the device at these or any other conditions beyond limits indicated in the operational sections is not recommended. Exposure to absolute maximum rating conditions for extended periods may affect device reliability and performance.
2. For Cold Spare mode (V_{DD1}=VSS, V_{DD2}=VSS), V_{I/O} may be -0.3V to the maximum recommended operating level of V_{DD1} +0.3V.
3. Maximum junction temperature may be increased to +175°C during burn-in and life test.

DUAL SUPPLY OPERATING CONDITIONS

SYMBOL	PARAMETER	LIMIT	UNITS
V _{DD1}	Supply voltage	2.3 to 3.6	V
V _{DD2}	Supply voltage	2.3 to 3.6	V
V _{IN}	Input voltage any pin	0 to V _{DD1}	V
T _C	Temperature range	-55 to + 125	°C

DC ELECTRICAL CHARACTERISTICS¹
(-55°C < T_C < +125°C)

SYMBOL	PARAMETER	CONDITION	MIN	MAX	UNIT
V _{T+}	Schmitt Trigger, positive going threshold ²	V _{DD} from 2.3 to 3.6		.7V _{DD}	V
V _{T-}	Schmitt Trigger, negative going threshold ²	V _{DD} from 2.3 to 3.6	.3V _{DD}		V
V _{H1}	Schmitt Trigger range of hysteresis ⁹	V _{DD} from 3.0 to 3.6	0.5		V
V _{H2}	Schmitt Trigger range of hysteresis ⁹	V _{DD} from 2.3 to 2.7	0.4		V
I _{IN}	Input leakage current ⁹	V _{DD} from 2.7 to 3.6 V _{IN} = V _{DD} or V _{SS}	-1	3	μA
I _{OZ}	Three-state output leakage current ⁹	V _{DD} from 2.7 to 3.6 V _{IN} = V _{DD} or V _{SS}	-1	3	μA
I _{CS}	Cold sparing input leakage current ^{3,11}	V _{IN} = 3.6 V _{DD} = V _{SS}	-5	5	μA
I _{WS}	Warm sparing input leakage current ^{3,11}	V _{IN} = V _{SS} or V _{DD} , V _{DD1} = 0, V _{DD2} = V _{DD} or V _{DD1} = V _{DD} , V _{DD2} = 0	-5	5	μA
I _{OS1}	Short-circuit output current ^{5, 10}	V _O = V _{DD} or V _{SS} V _{DD} from 3.0 to 3.6	-200	200	mA
I _{OS2}	Short-circuit output current ^{5, 10}	V _O = V _{DD} or V _{SS} V _{DD} from 2.3 to 2.7	-100	100	mA
V _{OL1}	Low-level output voltage ⁹	I _{OL} = 8mA I _{OL} = 100μA V _{DD} = 3.0		0.4 0.2	V
V _{OL2}	Low-level output voltage ⁹	I _{OL} = 8mA I _{OL} = 100μA V _{DD} = 2.3		0.4 0.2	V
V _{OH1}	High-level output voltage ⁹	I _{OH} = -8mA I _{OH} = -100μA V _{DD} = 3.0	V _{DD} - 0.7 V _{DD} - 0.2		V
V _{OH2}	High-level output voltage ⁹	I _{OH} = -8mA I _{OH} = -100μA V _{DD} = 2.3	V _{DD} - 0.7 V _{DD} - 0.2		V

DC ELECTRICAL CHARACTERISTICS¹
 (-55°C < T_C < +125°C)

SYMBOL	PARAMETER	CONDITION	MIN	MAX	UNIT
P _{total1}	Power dissipation ^{4,6,7}	C _L = 40pF V _{DD} from 3.0V to 3.6V		6.2	mW/ MHz
P _{total2}	Power dissipation ^{4,6,7}	C _L = 40pF V _{DD} from 2.3V to 2.7V		3	MHz
I _{DD}	Standby Supply Current V _{DD1} or V _{DD2} Pre-Rad 25°C Pre-Rad -55°C to +125°C Post-Rad 25°C	V _{IN} = V _{DD} or V _{SS} V _{DD} = 3.6V $\overline{OE} = V_{DD}$ $\overline{OE} = V_{DD}$ $\overline{OE} = V_{DD}$		10 475 15	μA μA mA
C _{IN}	Input Capacitance ⁸	f = 1MHz @ 0V V _{DD} from 2.3V to 3.6V		15	pF
C _{out}	Output Capacitance ⁸	f = 1MHz @ 0V V _{DD} from 2.3V to 3.6V		15	pF
POR	V _{DD1} & V _{DD2} Power-On ^{4,13}	V _{DD1} or V _{DD2} Zero Volt Offset V _{DD1} and V _{DD2} Rise-Time ¹²		250 500	mV mS

Notes:

1. All specifications valid for radiation dose ≤ 1E5 rad(Si) per MIL-STD-883, Method 1019.
2. Functional tests are conducted in accordance with MIL-STD-883 with the following input test conditions: V_{IH} = V_{IH}(min) + 20%, - 0%; V_{IL} = V_{IL}(max) + 0%, - 50%, as specified herein, for TTL, CMOS, or Schmitt compatible inputs. Devices may be tested using any input voltage within the above specified range, but are guaranteed to V_{IH}(min) and V_{IL}(max).
3. All combinations of $\overline{OE}x$ and DIRx
4. Guaranteed by characterization.
5. Not more than one output may be shorted at a time for maximum duration of one second.
6. Power does not include power contribution of any CMOS output sink current.
7. Power dissipation specified per switching output.
8. Capacitance measured for initial qualification and when design changes may affect the value. Capacitance is measured between the designated terminal and V_{SS} at frequency of 1MHz and a signal amplitude of 50mV rms maximum.
9. Guaranteed; tested on a sample of pins per device.
10. Supplied as a design limit, but not guaranteed or tested.
11. Zero Volts is defined as 0.0 Volts +/- 0.25Volts.
12. V_{DD1} and V_{DD2} Voltage rise is monotonic.
13. Rise time measured from V_{DD} @ Zero Volts to V_{DD} @ greater than 2.3 V.

AC ELECTRICAL CHARACTERISTICS¹ (Port B = 3.3 Volt, Port A = 2.5 Volt)

($V_{DD1} = 3.0V$ to $3.6V$; $V_{DD2} = 2.3V$ to $2.7V$, $-55^{\circ}C < T_C < +125^{\circ}C$)

SYMBOL	PARAMETER	MINIMUM	MAXIMUM	UNIT
t_{PLH}	Propagation delay Data to Bus	2	10	ns
t_{PHL}	Propagation delay Data to Bus	2	10	ns
t_{PZL}	Output enable time $\overline{OE}x$ to Bus	2	12	ns
t_{PZH}	Output enable time $\overline{OE}x$ to Bus	2	12	ns
t_{PLZ}	Output disable time $\overline{OE}x$ to Bus high impedance	2	15	ns
t_{PHZ}	Output disable time $\overline{OE}x$ to Bus high impedance	2	15	ns
t_{PZL}^2	Output enable time DIRx to Bus	2	12	ns
t_{PZH}^2	Output enable time DIRx to Bus	2	12	ns
t_{PLZ}^2	Output disable time DIRx to Bus high impedance	2	15	ns
t_{PHZ}^2	Output disable time DIRx to Bus high impedance	2	15	ns
t_{SLH}^3	Skew between outputs (40pF +/- 10 pF on each output)	0	900	ps
t_{SHL}^3	Skew between outputs (40pF +/- 10 pF on each output)	0	900	ps

Notes:

- All specifications valid for radiation dose $\leq 1E5$ rad(Si) per MIL-STD-883, Method 1019.
- DIRx to bus times are guaranteed by design, but not tested. $\overline{OE}x$ to bus times are tested
- Output skew is defined as a comparison of any two output transitions high-to-low vs. high-to-low and low-to-high vs. low-to-high

Propagation Delay

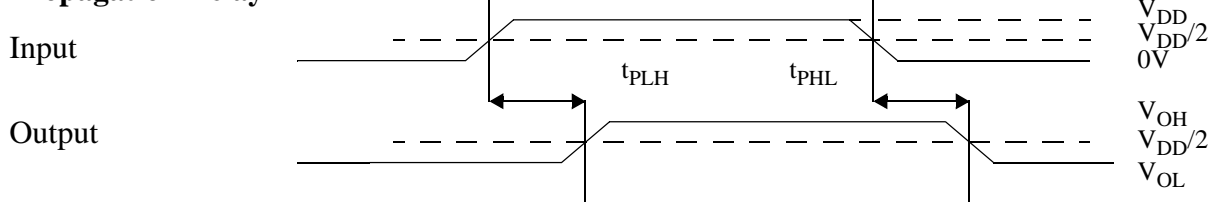

Enable Disable Times

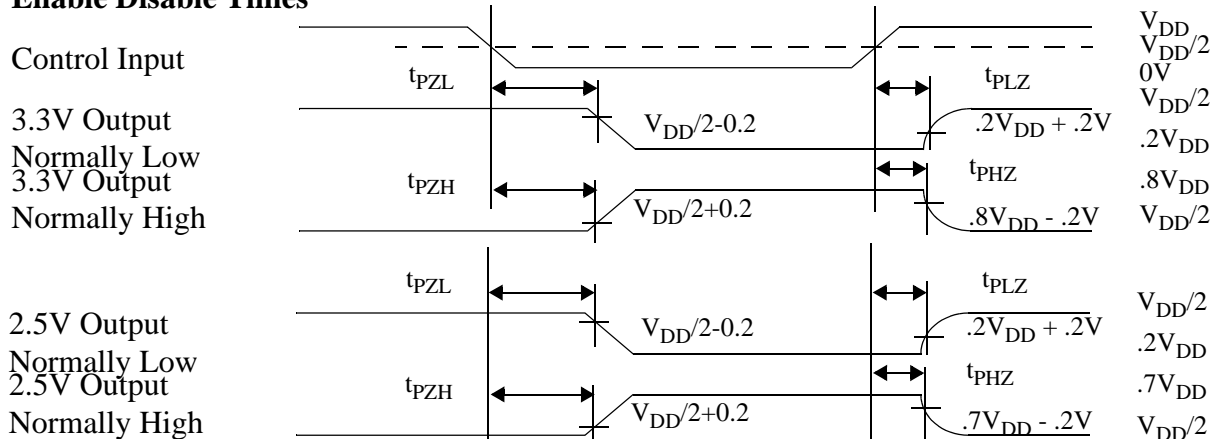

AC ELECTRICAL CHARACTERISTICS¹ (Port A = Port B, 3.3 Volt Operation)

($V_{DD1} = 3.0$ to $3.6V$; $V_{DD2} = 3.0V$ to $3.6V$, $-55^{\circ}C < T_C < +125^{\circ}C$)

SYMBOL	PARAMETER	MINIMUM	MAXIMUM	UNIT
t_{PLH}	Propagation delay Data to Bus	2	7.5	ns
t_{PHL}	Propagation delay Data to Bus	2	7.5	ns
t_{PZL}	Output enable time $\overline{OE}x$ to Bus	2	10	ns
t_{PZH}	Output enable time $\overline{OE}x$ to Bus	2	10	ns
t_{PLZ}	Output disable time $\overline{OE}x$ to Bus high impedance	2	12	ns
t_{PHZ}	Output disable time $\overline{OE}x$ to Bus high impedance	2	12	ns
t_{PZL}^2	Output enable time DIRx to Bus	2	10	ns
t_{PZH}^2	Output enable time DIRx to Bus	2	10	ns
t_{PLZ}^2	Output disable time DIRx to Bus high impedance	2	12	ns
t_{PHZ}^2	Output disable time DIRx to Bus high impedance	2	12	ns
t_{SLH}^3	Skew between outputs (40pF +/- 10 pF on each output)	0	900	ps
t_{SHL}^3	Skew between outputs (40pF +/- 10 pF on each output)	0	900	ps

Notes:

1. All specifications valid for radiation dose $\leq 1E5$ rad(Si) per MIL-STD-883, Method 1019.
2. DIRx to bus times are guaranteed by design, but not tested. $\overline{OE}x$ to bus times are tested
3. Output skew is defined as a comparison of any two output transitions high-to-low vs. high-to-low and low-to-high vs. low-to-high

Propagation Delay

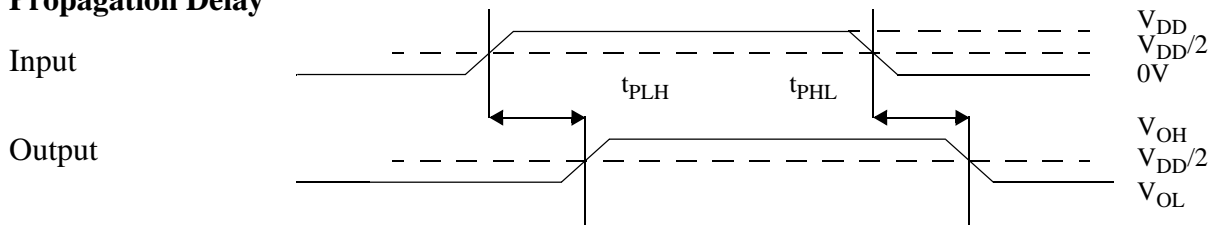

Enable Disable Times

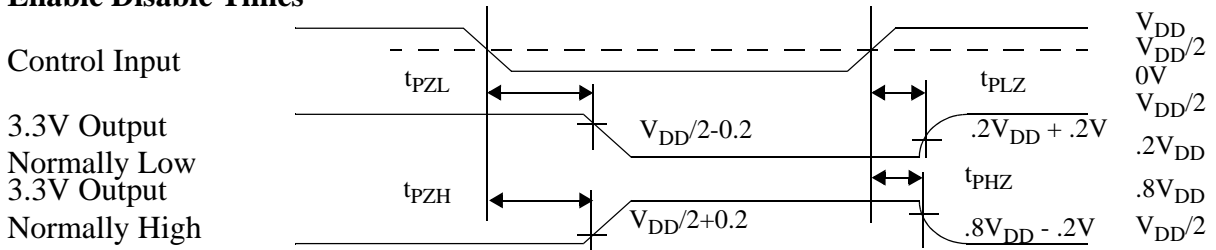

AC ELECTRICAL CHARACTERISTICS¹ (Port A = Port B, 2.5 Volt Operation)

($V_{DD1} = 2.3V$ TO $2.7V$; $V_{DD2} = 2.3V$ TO $2.7V$, $-55^{\circ}C < T_C < +125^{\circ}C$)

SYMBOL	PARAMETER	MINIMUM	MAXIMUM	UNIT
t_{PLH}	Propagation delay Data to Bus	2	10	ns
t_{PHL}	Propagation delay Data to Bus	2	10	ns
t_{PZL}	Output enable time $\overline{OE}x$ to Bus	2	12	ns
t_{PZH}	Output enable time $\overline{OE}x$ to Bus	2	12	ns
t_{PLZ}	Output disable time $\overline{OE}x$ to Bus high impedance	2	15	ns
t_{PHZ}	Output disable time $\overline{OE}x$ to Bus high impedance	2	15	ns
t_{PZL}^2	Output enable time DIRx to Bus	2	12	ns
t_{PZH}^2	Output enable time DIRx to Bus	2	12	ns
t_{PLZ}^2	Output disable time DIRx to Bus high impedance	2	15	ns
t_{PHZ}^2	Output disable time DIRx to Bus high impedance	2	15	ns
t_{SLH}^3	Skew between outputs (40pF +/- 10 pF on each output)	0	900	ps
t_{SHL}^3	Skew between outputs (40pF +/- 10 pF on each output)	0	900	ps

Notes:

1. All specifications valid for radiation dose $\leq 1E5$ rad(Si) per MIL-STD-883, Method 1019.
2. DIRx to bus times are guaranteed by design, but not tested. $\overline{OE}x$ to bus times are tested
3. Output skew is defined as a comparison of any two output transitions high-to-low vs. high-to-low and low-to-high vs. low-to-high

Propagation Delay

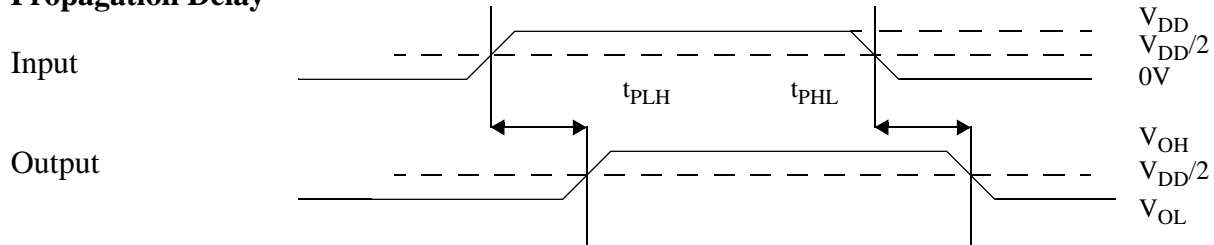

Enable Disable Times

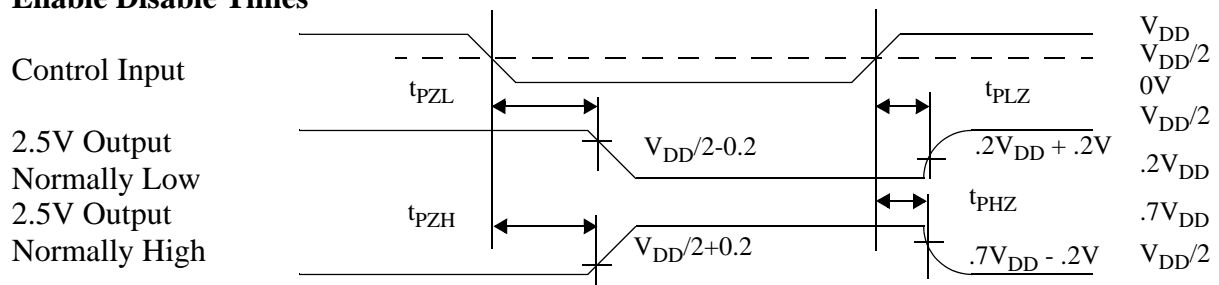

PACKAGE

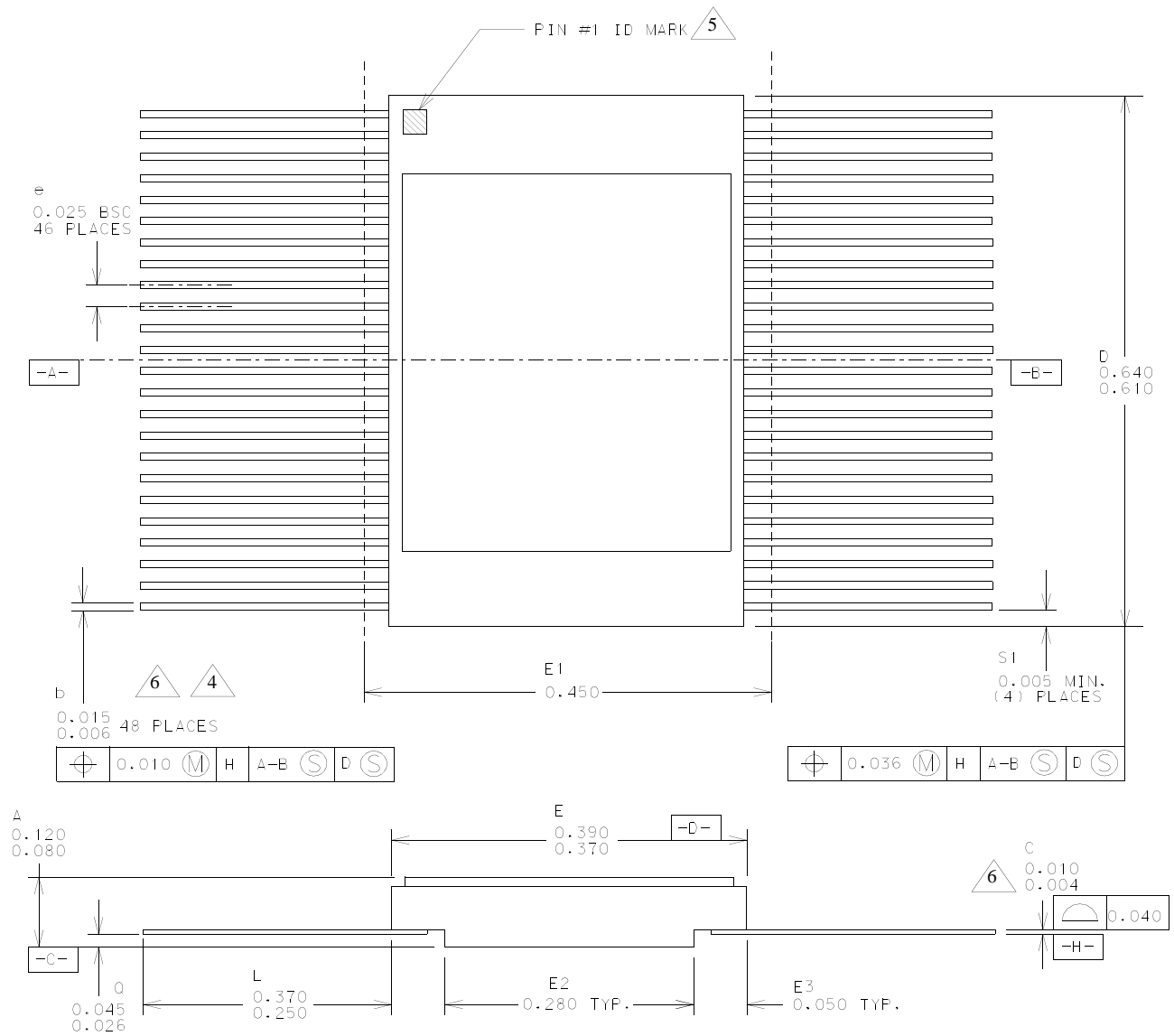

1. All exposed metalized areas are gold plated over electroplated nickel per MIL-PRF-38535.
2. The lid is electrically connected to VSS.
3. Lead finishes are in accordance with MIL-PRF-38535.
4. Lead position and colanarity are not measured.
5. ID mark symbol is vendor option.
6. With solder, increase maximum by 0.003.

Figure 1. 48-Lead Flatpack

ORDERING INFORMATION

UT54ACS162245S: SMD

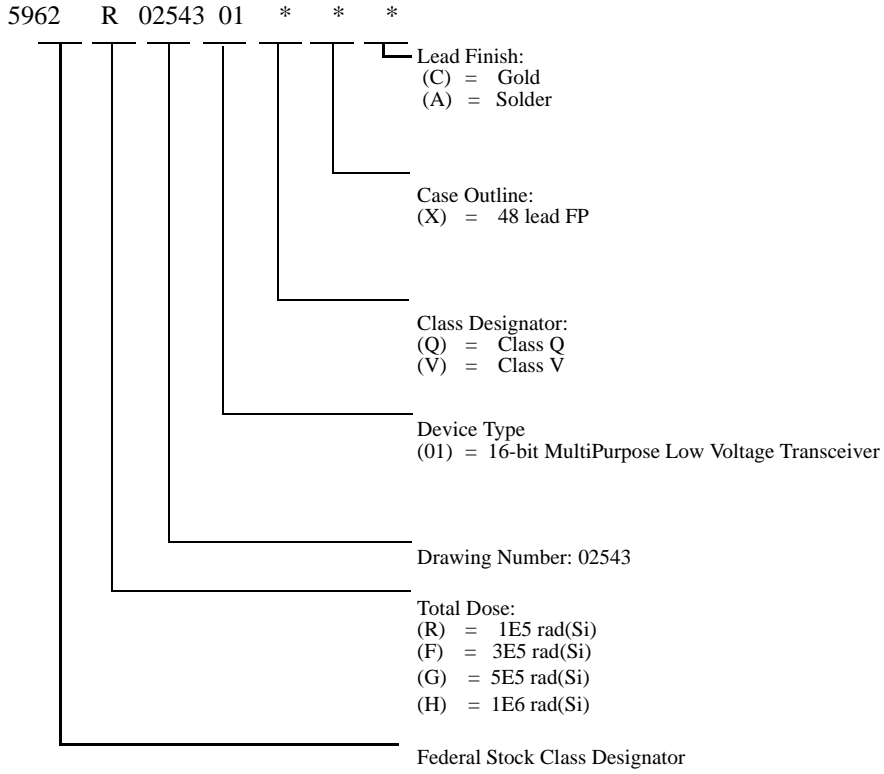

Notes:

1. Total dose radiation must be specified when ordering. QML Q and QML V not available without radiation hardening.

UT54ACS162245S

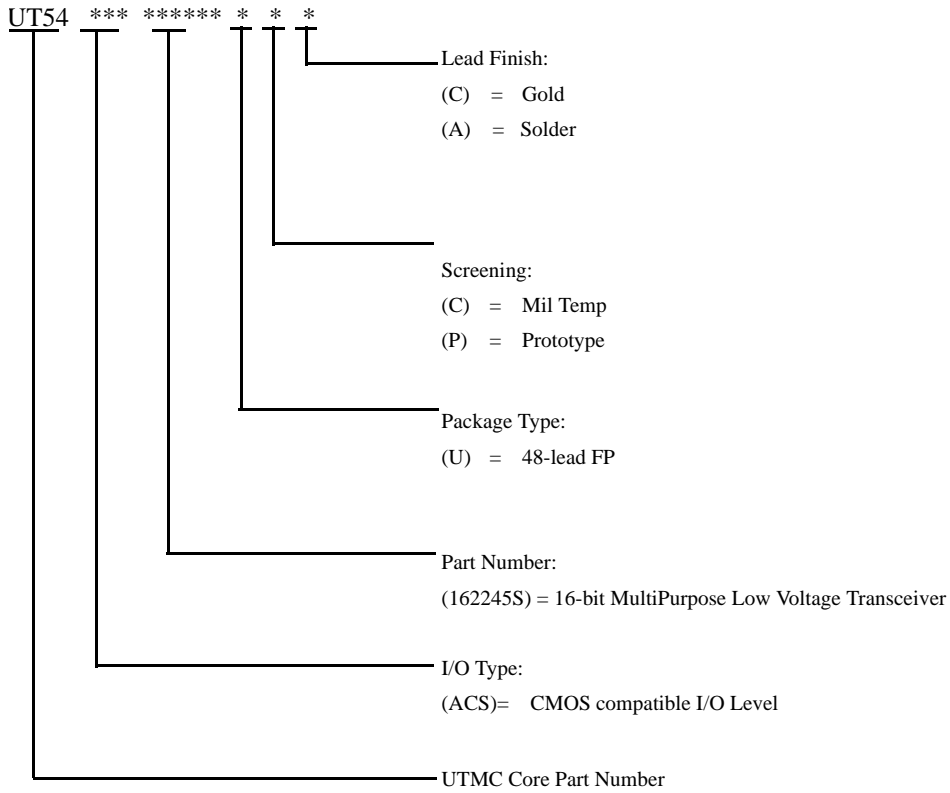

Notes:

1. Military Temperature Range flow per UTMC Manufacturing Flows Document. Devices are tested -55C, room temp, and 125C. Radiation neither tested nor guaranteed.
2. Prototype flow per UTMC Manufacturing Flows Document Tested at 25C only. Lead finish is gold only.

COLORADO

Toll Free: 800-645-8862
 Fax: 719-594-8468

INTERNATIONAL

Tel: 805-778-9229
 Fax: 805-778-1980

NORTHEAST

Tel: 603-888-3975
 Fax: 603-888-4585

SE AND MID-ATLANTIC

Tel: 321-951-4164
 Fax: 321-951-4254

WEST COAST

Tel: 949-362-2260
 Fax: 949-362-2266

CENTRAL

Tel: 719-594-8017
 Fax: 719-594-8468

www.aeroflex.com info-ams@aeroflex.com

Aeroflex Colorado Springs, Inc. (Aeroflex) reserves the right to make changes to any products and services herein at any time without notice. Consult Aeroflex or an authorized sales representative to verify that the information in this data sheet is current before using this product. Aeroflex does not assume any responsibility or liability arising out of the application or use of any product or service described herein, except as expressly agreed to in writing by Aeroflex; nor does the purchase, lease, or use of a product or service from Aeroflex convey a license under any patent rights, copyrights, trademark rights, or any other of the intellectual rights of Aeroflex or of third parties.



Our passion for performance is defined by three attributes represented by these three icons: solution-minded, performance-driven and customer-focused