



400 MSPS 14-Bit, 1.8V CMOS Direct Digital Synthesizer

Preliminary Technical Data

AD9951

FEATURES

- 400 MSPS Internal Clock Speed
- Integrated 14-bit D/A Converter
- Programmable phase/amplitude dithering
- 32-bit Tuning Word
- Phase Noise ≤ 125 dBc/Hz @ 1KHz offset (DAC output)
- Excellent Dynamic Performance
 - 80dB SFDR @ 130MHz (+/- 100KHz Offset) Aout
- Serial I/O Control
- 1.8V Power Supply
- Software and Hardware controlled power down
- 48-lead EPAD-TQFP package
- Support for 5v input levels on most digital inputs

PLL REFCLK multiplier (4X to 20X)

- Internal oscillator, can be driven by a single crystal
- Phase modulation capability
- Multi-Chip Synchronization

APPLICATIONS

- Agile L.O. Frequency Synthesis
- FM Chirp Source for Radar and Scanning Systems
- Test and Measurement Equipment

Functional Block Diagram

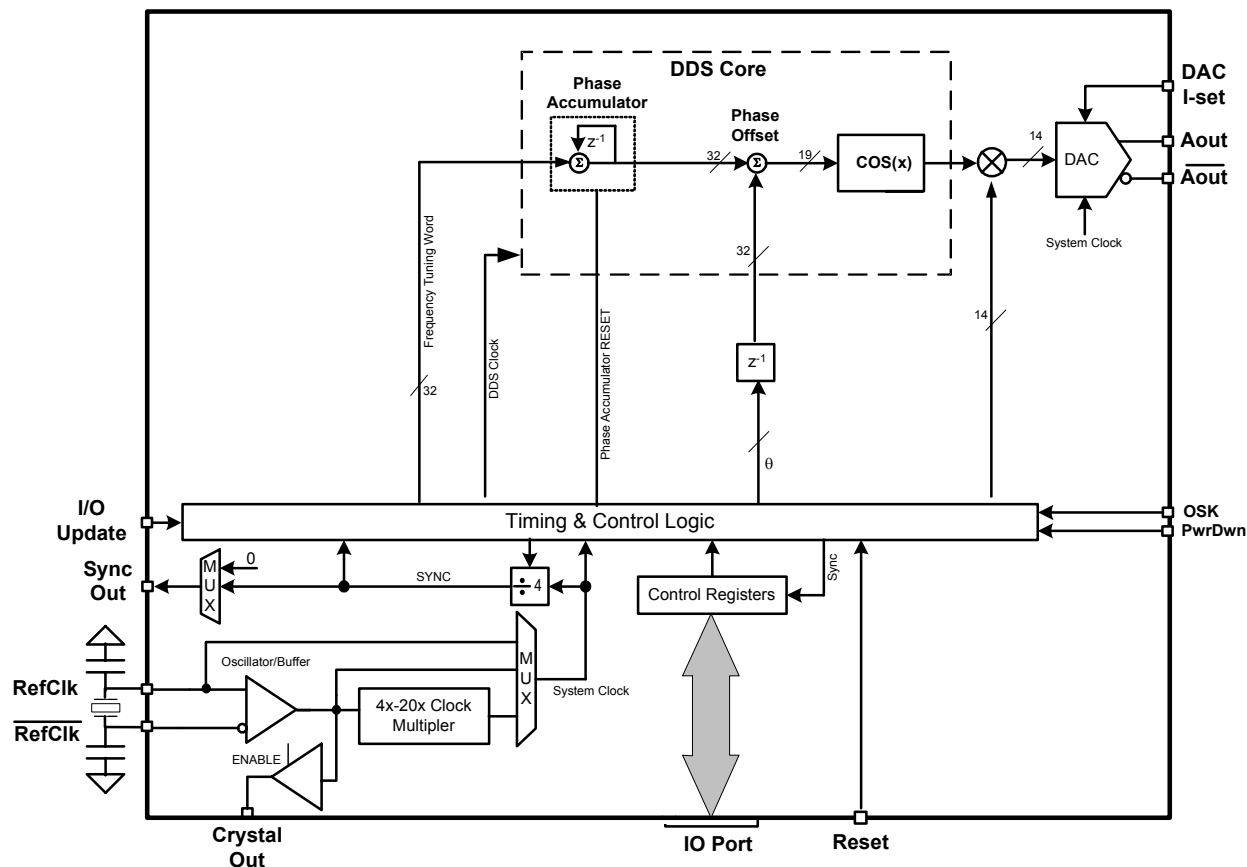

REV. PrB

Information furnished by Analog Devices is believed to be accurate and reliable. However, no responsibility is assumed by Analog Devices for its use, nor for any infringements of patents or other rights of third parties that may result from its use. No license is granted by implication or otherwise under any patent or patent rights of Analog Devices. Trademarks and registered trademarks are the property of their respective companies.

One Technology Way, P.O. Box 9106, Norwood, MA 02062-9106, U.S.A.

Tel: 781/329-4700

www.analog.com

Fax: 781/326-8703

© 2003 Analog Devices, Inc. All rights reserved.

GENERAL DESCRIPTION

The AD9951 is a Direct Digital Synthesizer (DDS) featuring a 14-bit DAC operating up to 400MSPS. The AD9951 uses advanced DDS technology, coupled with an internal high-speed, high performance D/A converter to form a digitally-programmable, complete high-frequency synthesizer capable of generating a frequency-agile analog output sinusoidal waveform at up to 200 MHz. The AD9951 is designed to provide fast

frequency hopping and fine tuning resolution (32-bit frequency tuning word). The frequency tuning and control words are loaded into the AD9951 via a serial I/O port.

The AD9951 is specified to operate over the extended industrial temperature range of -40° to +85°C.

ABSOLUTE MAXIMUM RATINGS¹

Maximum Junction Temp. +150 °C
Vs +4 V
Digital Input Voltage..... -0.7 V to +Vs
Digital Output Current 5 mA

Storage Temperature -65 °C to +150 °C
Operating Temp. -40 °C to +85 °C
Lead Temp. (10 sec. soldering) +300 °C
 θ_{JA} TBD °C/W
 θ_{JC} TBD °C/W

* Absolute maximum ratings are limiting values, to be applied individually, and beyond which the serviceability of the circuit may be impaired. Functional operability under any of these conditions is not necessarily implied. Exposure of absolute maximum rating conditions for extended periods of time may affect device reliability.

CONTENTS

Functional Block Diagram	1
GENERAL DESCRIPTION	2
AD9951 PRELIMINARY ELECTRICAL SPECIFICATIONS	4
AD9951 Pinmap	7
Pin Name	8
I/O	8
Theory of Operation	10
Component Blocks	10
DDS Core	10
Phase Truncation	11
Clock Input	11
Phase Locked Loop (PLL)	12
DAC Output	12
Serial IO Port	13
Register Maps and Descriptions	13
AD9951 Register Map	14
Default	14
Control Register Bit Descriptions	15
Control Function Register #1 (CFR1)	15
Control Function Register #1 (CFR2)	19
Other Register Descriptions	20
Amplitude Scale Factor (ASF)	20
Amplitude Ramp Rate (ARR)	20
Frequency Tuning Word 0 (FTW0)	20
Phase Offset Word (POW)	20

PRELIMINARY TECHNICAL DATA**AD9951**

Frequency Tuning Word 1 (FTW1)	Error! Bookmark not defined.
Mode of Operation	20
Single Tone Mode	21
<u>Continuous Clear and “Clear and Release” Phase Accumulator Clear Functions</u>	21
Continuous Clear bits	21
Clear and Release function	21
Programming AD9951 Features	21
Phase Offset Control	21
Phase/Amplitude Dithering	21
Shaped On-Off Keying	22
AUTO Shaped On-Off Keying mode operation:	23
OSK Ramp Rate Timer	24
External Shaped On-Off Keying mode operation:	24
Synchronization; Register Updates (I/O UPDATE)	25
Functionality of the SyncClk and I/O UPDATE	25
Figure D- I/O Synchronization Block Diagram	26
Figure E - I/O Synchronization Timing Diagram	26
Synchronizing Multiple AD9951s	Error! Bookmark not defined.
Using a Single Crystal To Drive Multiple AD9951 Clock Inputs	Error! Bookmark not defined.
Serial Port Operation	28
Instruction Byte	29
Serial Interface Port Pin Description	30
MSB/LSB Transfers	30
Example Operation	31
Notes on Serial Port Operation	31
Power Down Functions of the AD9951	31
Digital and Input Clock Power Down	32
AD9951 Application Suggestions	33

PRELIMINARY TECHNICAL DATA
AD9951 PRELIMINARY ELECTRICAL SPECIFICATIONS

AD9951

(Unless otherwise noted: (V_S+1.8 V ±5%, R_{SET}=1.96 kΩ, External reference clock frequency = 20 MHz with REFCLK Multiplier enabled at 20×)

Parameter	Temp	Test Level	AD9951			Units
			Min	Typ	Max	
REF CLOCK INPUT CHARACTERISTICS						
Frequency Range						
REFCLK Multiplier Disabled	FULL	VI	1		400	MHz
REFCLK Multiplier Enabled at 4X	FULL	VI	20		100	MHz
REFCLK Multiplier Enabled at 20X	FULL	VI	4		20	MHz
Input Capacitance	+25°C	V		3		pF
Input Impedance	+25°C	V		100		MΩ
Duty Cycle	+25°C	V		50		%
Duty Cycle with REFCLK Multiplier Enabled	+25°C	V	35		65	%
DAC OUTPUT CHARACTERISTICS						
Resolution				14		Bits
Full Scale Output Current	+25°C		5	10	15	mA
Gain Error	+25°C	I	-10		+10	%FS
Output Offset	+25°C	I			0.6	μA
Differential Nonlinearity	+25°C	V		1		LSB
Integral Nonlinearity	+25°C	V		2		LSB
Output Capacitance	+25°C	V		5		pF
Residual Phase Noise @ 1 kHz Offset, 40 MHz A _{out}						
REFCLK Multiplier Enabled @ 20×	+25°C	V		-89		dBc/Hz
REFCLK Multiplier Enabled @ 4×	+25°C	V		-105		dBc/Hz
REFCLK Multiplier Disabled	+25°C	V		-116		dBc/Hz
Voltage Compliance Range	+25°C	I	AVDD- 0.375		AVDD + 0.25V	V
Wideband SFDR:						
1 – 20 MHz Analog Out	+25°C	V				dBc
20 – 40 MHz Analog Out	+25°C	V				dBc
40 – 60 MHz Analog Out	+25°C	V				dBc
60 – 80 MHz Analog Out	+25°C	V				dBc
80 – 100 MHz Analog Out	+25°C	V				dBc
100 – 120 MHz Analog Out	+25°C	V				dBc
120 – 140 MHz Analog Out	+25°C	V				dBc
140 – 160 MHz Analog Out	+25°C	V				dBc
Narrow Band SFDR						
10 MHz Analog Out (±1 MHz)	+25°C	V				dBc
10 MHz Analog Out (±250 kHz)	+25°C	V				dBc
10 MHz Analog Out (± 50 kHz)	+25°C	V				dBc
10 MHz Analog Out (± 10 kHz)	+25°C	V				dBc
65 MHz Analog Out (± 1 MHz)	+25°C	V				dBc
65 MHz Analog Out (± 250 kHz)	+25°C	V				dBc
65 MHz Analog Out (± 50 kHz)	+25°C	V				dBc
65 MHz Analog Out (± 10 kHz)	+25°C	V				dBc
80 MHz Analog Out (± 1 MHz)	+25°C	V				dBc
80 MHz Analog Out (± 250 kHz)	+25°C	V				dBc
80 MHz Analog Out (± 50 kHz)	+25°C	V				dBc
80 MHz Analog Out (± 10 kHz)	+25°C	V				dBc
100 MHz Analog Out (± 1 MHz)	+25°C	V				dBc
100 MHz Analog Out (± 250 kHz)	+25°C	V				dBc
100 MHz Analog Out (± 50 kHz)	+25°C	V				dBc
100 MHz Analog Out (± 10 kHz)	+25°C	V				dBc
120 MHz Analog Out (± 1 MHz)	+25°C	V				dBc
120 MHz Analog Out (± 250 kHz)	+25°C	V				dBc
120 MHz Analog Out (± 50 kHz)	+25°C	V				dBc
120 MHz Analog Out (± 10 kHz)	+25°C	V				dBc
140 MHz Analog Out (± 1 MHz)	+25°C	V				dBc
140 MHz Analog Out (± 250 kHz)	+25°C	V				dBc
140 MHz Analog Out (± 50 kHz)	+25°C	V				dBc
140 MHz Analog Out (± 10 kHz)	+25°C	V				dBc
160 MHz Analog Out (± 1 MHz)	+25°C	V				dBc
160 MHz Analog Out (± 250 kHz)	+25°C	V				dBc

PRELIMINARY TECHNICAL DATA

AD9951

Parameter	Temp	Test Level	Min	Typ	Max	Units
160 MHz Analog Out (± 50 kHz)	+25°C	V				dBc
160MHz Analog Out (± 10 kHz)	+25°C	V				dBc
TIMING CHARACTERISTICS						
Serial Control Bus	FULL	IV				
Maximum Frequency	FULL	IV			25	MHz
Minimum Clock Pulse Width Low (t_{PWL})	FULL	IV	7			ns
Minimum Clock Pulse Width High (t_{PWH})	FULL	IV	7			ns
Maximum Clock Rise/Fall Time	FULL	IV		5		ns
Minimum Data Setup Time (t_{DS})	FULL	IV	10			ns
Minimum Data Hold Time (t_{DH})	FULL	IV	0			ns
Maximum Data Valid Time (t_{DV})	FULL	IV	25			ns
Wake-Up Time ²	FULL	IV		1		ms
Minimum Reset Pulsewidth High (t_{RH})	FULL	IV	5			SYSCLOCK cycles ³
CMOS LOGIC INPUTS						
Logic "1" Voltage @ DVDD = 1.8V	+25°C	I				V
Logic "0" Voltage @ DVDD = 1.8V	+25°C	I			TBD	V
Logic "1" Voltage @ DVDD = 3.3V	+25°C	I		%		
Logic "0" Voltage @ DVDD = 3.3V	+25°C	I		%		
Logic "1" Current	+25°C	V		3	12	μ A
Logic "0" Current	+25°C				12	μ A
Input Capacitance	+25°C					pF
CMOS LOGIC OUTPUTS (1mA load)						
Logic "1" Voltage (include for both DVDD)	+25°C	I	TBD			V
Logic "0" Voltage	+25°C	I			0.4	V
POWER SUPPLY						
+VS Current	+25°C	I			30	mA
Full Operating Conditions	+25°C	I			TBD	mA
400 MHz Clock	+25°C	I			TBD	mA
120 MHz Clock	+25°C	I			TBD	mA
Power-Down Mode	+25°C	I			TBD	mA
Full-Sleep Mode	+25°C	I			TBD	mA

NOTES

¹Absolute maximum ratings are limiting values to be applied individually, and beyond which the serviceability of the circuit may be impaired. Functional operability under any of these conditions is not necessarily implied. Exposure of absolute maximum rating conditions for extended periods of time affect device reliability.

²Wake-Up Time refers to recovery from analog power down modes (see Power Down Modes of Operation). The longest time required is for the Reference Clock Multiplier PLL to lock up (if it is being used). The Wake-Up Time assumes that there is no capacitor on DAC_BP, and that the recommended PLL loop filter values are used.

³SYSCLOCK refers to the actual clock frequency used on-chip by the AD9951. If the Reference Clock Multiplier is used to multiply the external reference frequency, then the SYSCLOCK frequency is the external frequency multiplied by the Reference Clock Multiplier multiplication factor. If the Reference Clock Multiplier is not used, then the SYSCLOCK frequency is the same as the external REFCLK frequency.

Specifications are subject to change without notice.

EXPLANATION OF TEST LEVELS

- I – 100% Production Tested.
- II – 100% Production Tested at +25°C and sample tested at specified temperatures.
- III – Sample Tested Only.
- IV – Parameter is guaranteed by design and characterization testing.
- V – Parameter is a typical value only.
- VI – Devices are 100% production tested at +25°C and guaranteed by design and characterization testing for industrial operating temperature range.

PRELIMINARY TECHNICAL DATA

AD9951

ORDERING GUIDE

Model	Temperature Range	Package Description	Package Option
AD9951ASV	-40°C to +85°C	48-lead QFP EPAD	SV-48
AD9951PCB	+25°C	Evaluation Board	

CAUTION

ESD (electrostatic discharge) sensitive device. Electrostatic charges as high as 4000 V readily accumulate on the human body and test equipment and can discharge without detection. Although the AD9951 features proprietary ESD protection circuitry, permanent damage may occur on devices subjected to high-energy electrostatic discharges. Therefore, proper ESD precautions are recommended to avoid performance degradation or loss of functionality.



Hardware Pin Descriptions

Pin #	Pin Name	I/O	Description
1	I/O UPDATE	I	The rising edge transfers the contents of the internal buffer memory to the IO Registers.
2,34	DVDD	I	Digital power supply pins.
3,33, 42, 47,48	DGND	I	Digital power ground pins.
4,6, 13,16,18,19, 25,27, 29	AVDD	I	Analog power supply pins.
5,7, 14,15, 17,22, 26,30, 31, 32	AGND	I	Analog power ground pins.
8	OSCB/REFCLKB	I	Complementary reference clock/oscillator input (400MHz max.). NOTE: When the REFCLK port is operated in single-ended mode, then REFCLKB should be decoupled to AVDD with a 0.1 μ F capacitor.
9	OSC/REFCLK	I	Reference clock/oscillator input (400 MHz max.). See Clock Input section of datasheet for details on the REFCLK/OSCILLATOR operation.
10	Crystal Out	O	Output of the oscillator section.
11	ClkModeSelect	I	Control pin for the oscillator section. When high, the oscillator section is enabled. When low, the oscillator section is bypassed.
12	LOOP_FILTER	I	This Pin provides the connection for the external zero compensation network of the REFCLK Multiplier's PLL loop filter. The network consists of a 1K ohm resistor in series with a 0.1 μ F capacitor tied to AVDD.
20	IOUTB	O	Complementary DAC output.
21	IOUT	O	DAC output.
23	DACBP	I	DAC "biasline" decoupling pin.
24	DAC_Rset	I	A resistor (3.85K Ω nominal) connected from AGND to DAC_Rset establishes the reference current for the DAC.
28	NC	X	No Connect, leave pin floating.
35	PwrDwnCtl	I	Input pin used as an external power down control. See the External Power Down Control section of this document for details.
36	RESET	I	Active high hardware reset pin. Assertion of the RESET pin forces the AD9951 to the initial state, as described in the IO Port Register map.
37	IOSYNC	I	Asynchronous active high reset of the serial port controller. When high, the current IO operation is immediately terminated enabling a new IO operation to commence once IOSYNC is returned low

38	SDO	O	When operating the I/O port as a 3-wire serial port this pin serves as the serial data output. When operated as a 2-wire serial port this pin is the unused and can be left unconnected.
39	CS-BAR	I	This pin functions as an active low chip select that allows multiple devices to share the IO bus.
40	SCLK	I	This pin functions as the serial data clock for IO operations
41	SDIO	I/O	When operating the I/O port as a <i>3-wire</i> serial port this pin serves as the serial <i>data input</i> , only. When operated as a <i>2-wire</i> serial port this pin is the <i>bi-directional serial data</i> pin.
43	DVDD I/O	I	Digital power supply (for IO cells only, 3.3v optional)
44	SYNC_IN	I	Input signal used to synchronize multiple AD9951s. This input is connected to the SYNC_CLK output of a different AD9951.
45	SYNC_CLK	O	Clock output pin, which serves as a synchronizer for external hardware.
46	OSK	I	Input pin used to control the direction of the Shaped On-Off Keying function when programmed for operation. OSK is synchronous to the SYNC_CLK pin. When OSK is not programmed, this pin should be tied to DGND.

Table 1 Hardware Pin Descriptions

Component Blocks

DDS Core

The output frequency (f_o) of the DDS is a function of the frequency of system clock (**SYSCLK**), the value of the frequency tuning word (FTW), and the capacity of the accumulator (2^{32} , in this case). The exact relationship is given below with f_s defined as the frequency of **SYSCLK**.

$$f_o = (\text{FTW})(f_s) / 2^{32} \quad \{ 0 \leq \text{FTW} \leq 2^{31}$$

$$f_o = f_s * (1 - (\text{FTW} / 2^{32})) \quad \{ 2^{31} < \text{FTW} < 2^{32} - 1$$

The AD9951 frequency tuning word(s) are unsigned numbers, where 80000000(hex) represents the highest output frequency possible, commonly referred to as the Nyquist frequency. Values ranging from than 80000001(hex) to FFFFFFFF(hex) will be expressed as aliased frequencies less than Nyquist. An example using a 3-bit phase accumulator will illustrate this principle. For a tuning word of 001, the phase accumulator output (PAO) increments from all zeros to all ones and repeats when the accumulator overflows after clock cycle number 8. For the tuning word of 111, the phase accumulator output (PAO) decrements from all ones to all zeros and repeats when the accumulator overflows after clock cycle number 8. While the phase accumulator outputs are “reversed” with respect to clock cycles, the outputs provide identical inputs to the phase to amplitude converter, which means the DDS output frequencies are identical.

Mathematically, for a 3-bit accumulator, the following equations apply:

$$f_o = f_s * (\text{FTW} / 2^3) \quad \{ 0 \leq \text{FTW} \leq 2^2$$

$$f_o = f_s * (1 - (\text{FTW} / 2^3)) \quad \{ 2^2 < \text{FTW} < 2^3 - 1$$

For the 001 frequency tuning word:

$$F_{out} = F_s * 1/2^3 = 1/8 * F_s$$

And for the 111 frequency tuning word:

$$F_{out} = F_s * (1 - 7/8) = 1/8 * F_s$$

The value at the output of the Phase Accumulator is translated to an amplitude value via the COS(x) functional block and routed to the DAC.

In certain applications it is desirable to force the output signal to ZERO phase. Simply setting the FTW to 0 does not accomplish this. It only results in the DDS core holding its current phase value. Thus, a control bit is required to force the Phase Accumulator output to zero.

At power up the Clear Phase Accumulator bit is set to logic one but the buffer memory for this bit is cleared (logic zero). Therefore, upon power up, the phase accumulator will remain clear until the first I/O UPDATE is issued.

Phase Truncation

The 32-bit phase values generated by the Phase Accumulator are truncated to 19 bits prior to the COS(x) block. That is, the 19 most significant bits of phase are retained for subsequent processing. This is typical of standard DDS architecture and is a trade off between hardware complexity and spurious performance. It can be shown that 19-bit phase resolution is sufficient to yield 14-bit amplitude resolution with an error of less than $\frac{1}{2}$ LSB. The decision to truncate at 19 bits of phase guarantees the phase error of the COS(x) block to be less than the phase error associated with the amplitude resolution of the 14-bit DAC.

Clock Input

The AD9951 supports various clock methodologies. Support for differential or single-ended input clocks, enabling of an on-chip oscillator and/or phase-locked loop (PLL) multiplier are all controlled via user programmable bits. The AD9951 may be configured in one of six operating modes to generate the system clock. The modes are configured using the ClkModeSelect pin, CFR2<0>, and CFR2<7:3>. Connecting the external pin ClkModeSelect to logic HIGH enables the on-chip crystal oscillator circuit. With the on-chip oscillator enabled, users of the AD9951 connect an external crystal to the REFCLK and REFCLKB inputs to produce a low frequency reference clock in the range of 20-30MHz. The signal generated by the oscillator is buffered before it is delivered to the rest of the chip. This buffered signal is available via the crystal out pin. Bit CFR2<0> can be used to enable or disable the buffer, turning on or off the system clock. The oscillator itself is not powered down in order to avoid long start-up times associated with turning on a crystal oscillator. Writing bit CFR2<1> to logic HIGH enables the crystal oscillator output buffer. Logic LOW at CFR2<1> disables the oscillator output buffer.

Connecting ClkModeSelect to logic LOW disables the on-chip oscillator and the oscillator output buffer. With the oscillator disabled an external oscillator must provide the REFCLK and/or REFCLKB signals. For differential operation these pins are driven with complementary signals. For single-ended operation a 0.1uF capacitor should be connected between the unused pin and the positive power supply. With the capacitor in place the clock input pin bias voltage is 1.35V. In addition, the PLL may be used to multiply the reference frequency by an integer value in the range of the 4 to 20.

The modes of operation are summarized in the table below. Please note the PLL multiplier is controlled via the CFR2<7:3> bits, independently of the CFR2<0> bit.

ClkModeSelect	CFR2<0>	CFR2<7:3>	SYSTEM CLOCK	Frequency Range (MHz)
HIGH	LOW	3 < M < 21	$F_{clk} = F_{osc} \times M$	80 < F_{clk} < 400
HIGH	LOW	M < 4 or M > 20	$F_{clk} = F_{osc}$	20 < F_{clk} < 30
HIGH	HIGH	X	$F_{clk} = 0$	$F_{clk} = 0$
LOW	X	3 < M < 21	$F_{clk} = F_{ref} \times M$	80 < F_{clk} < 400
LOW	X	M < 4 or M > 20	$F_{clk} = F_{ref}$	5 < F_{clk} < 400

Table 2 Clock Input Modes of Operation

Phase Locked Loop (PLL)

The PLL is required to facilitate multiplication of the REFCLK frequency. Control of the PLL is accomplished by programming the 5-bit REFCLK Multiplier portion of Control Function Register #2, bits <7:3>.

When programmed for values ranging from 04h – 14h (4-20 decimal), the PLL multiplies the REFCLK input frequency by the corresponding decimal value. The maximum output frequency of the PLL is restricted to 400MHz, however. Whenever the PLL value is changed, the user should be aware that time must be allocated to allow the PLL to lock (approximately 1ms).

The PLL is bypassed by programming a value outside the range of 4-20 (decimal). When bypassed, the PLL is shut down to conserve power.

DAC Output

The AD9951 incorporates an integrated 14-bit current output DAC. Two complementary outputs provide a combined full-scale output current (I_{out}). Differential outputs reduce the amount of common-mode noise that might be present at the DAC output, offering the advantage of an increased signal-to-noise ratio. The full-scale current is controlled by means of an external resistor (R_{set}) connected between the DAC_Rset pin and the DAC ground (AGND_DAC). The full-scale current is proportional to the resistor value as follows:

$$R_{set} = 39.19/I_{out}$$

The maximum full-scale output current of the combined DAC outputs is <TBD>, but limiting the output to Y provides the best spurious-free-dynamic-range (SFDR) performance. The DAC output compliance range is <TBD>. Voltages developed beyond this range will cause excessive DAC distortion and could potentially damage the DAC output circuitry. Proper attention should be paid to the load termination to keep the output voltage within this compliance range.

Serial IO Port

The AD9951 serial port is a flexible, synchronous serial communications port allowing easy interface to many industry standard micro-controllers and microprocessors. The serial I/O port is compatible with most synchronous transfer formats, including both the Motorola 6905/11 SPI and Intel 8051 SSR protocols.

The interface allows read/write access to all registers that configure the AD9951. MSB first or LSB first transfer formats are supported. In addition, the AD9951's serial interface port can be configured as a single pin I/O (SDIO), which allows a two-wire interface or two unidirectional pins for in/out (SDIO/SDO), which enables a three wire interface. Two optional pins (IOSYNC and CSB) enable greater flexibility for system design-in of the AD9951.

Register Maps and Descriptions

The Register Map is listed in the following tables. The serial address numbers associated with each of the registers are shown in hexadecimal format. Angle brackets $\langle \rangle$ are used to reference specific bits or ranges of bits. For example, $\langle 3 \rangle$ designates bit 3 while $\langle 7:3 \rangle$ designates the range of bits from 7 down to 3, inclusive.

PRELIMINARY TECHNICAL DATA

AD9951

AD9951 Register Map

Register Name (Serial address)	Bit Range (Internal address)	(MSB) Bit 7	Bit 6	Bit 5	Bit 4	Bit 3	Bit 2	Bit 1	(LSB) Bit 0	Default Value
Control Function Register #1 (CFR1) (00h)	<7:0> (00h)	Digital Power Down	Open	DAC Power Down	Clock Input Power Dwn	External Power Down Mode	Open	Sync CLK Out Disable	Open	00h
	<15:8> (01h)	Open	Open	AutoClr Phase Accum	Enable SINE Output	Open	Clear Phase Accum.	SDIO Input Only	LSB First	00h
	<23:16> (02h)	Automatic Sync Enable	Software Manual Sync	Open	Amplitude Dither Enable	Phase Dither En<3>	Phase Dither En<2>	Phase Dither En<1>	Phase Dither En<0>	00h
	<31:24> (03h)	Open	Open	Not Used			Load ARR @FUD	Output Shaped Keying Enable	Auto Output Shaped Keying	00h
Control Function Register #2 (CFR2) (01h)	<7:0> (04h)	REFCLK Multiplier 00h or 01h or 02h or 03h: Bypass Multiplier 04h –14h: 4x – 20x multiplication				VCO Gain		Charge Pump Control <1:0>		00h
	<15:8> (05h)	Not Used				High Speed Sync Enable	Hardware Manual Sync Enable	Crystal Out Pin Active	DAC Prime Data Disable	00h
	<23:16> (06h)	Not used								00h
Amplitude Scale Factor (ASF) (02h)	<7:0> (07h)	Amplitude Scale Factor Register <7:0>								
	<15:8> (08h)	Auto Ramp Rate Speed Control <1:0>	Amplitude Scale Factor Register <13:8>							
Amplitude Ramp Rate (ARR) (03h)	<7:0> (09h)	Amplitude Ramp Rate Register <7:0>								
Frequency Tuning Word (FTW0) (04h)	<7:0> (0Ah)	Frequency Tuning Word #0 <7:0>								
	<15:8> (0Bh)	Frequency Tuning Word #0 <15:8>								
	<23:16> (0Ch)	Frequency Tuning Word #0 <23:16>								
	<31:24> (0Dh)	Frequency Tuning Word #0 <31:24>								
Phase Offset Word (POW0) (05h)	<7:0> (0Eh)	Phase Offset Word #0 <7:0>								
	<15:8> (0Fh)	Open<1:0>	Phase Offset Word #0 <13:8>							

Control Register Bit Descriptions**Control Function Register #1 (CFR1)**

The CFR1 is used to control the various functions, features, and modes of the AD9951. The functionality of each bit is detailed below.

CFR1<26>: Amplitude ramp rate load control bit.

When **CFR1<26>** = 0 (*default*), the amplitude ramp rate timer is loaded only upon timeout (timer ==1) and is NOT loaded due to an I/O UPDATE input signal.

When **CFR1<26>** = 1, the amplitude ramp rate timer is loaded upon timeout (timer ==1) or at the time of an I/O UPDATE input signal.

CFR1<25>: Shaped On-Off Keying enable bit.

When **CFR1<25>** = 0 (*default*), Shaped On-Off Keying is bypassed.

When **CFR1<25>** = 1, Shaped On-Off Keying is enabled. When enabled, CFR1<24> controls the mode of operation for this function.

CFR1<24>: AUTO Shaped On-Off Keying enable bit (only valid when CFR1<25> is active high).

When **CFR1<24>** = 0 (*default*). When CFR1<25> is active, a logic 0 on CFR1<24> enables the MANUAL Shaped On-Off Keying operation. See the **Shaped On-Off Keying** section of this document for details.

When **CFR1<24>** = 1, if CFR1<25> is active, a logic 1 on CFR1<24> enables the AUTO Shaped On-Off Keying operation. See the **Shaped On-Off Keying** section of this document for details.

CFR1<23>: Automatic Synchronization Mode.

When **CFR1<23>** = 0 (*default*), the automatic synchronization of multiple AD9951s feature is inactive.

When **CFR1<23>** = 1, the automatic synchronization feature is active. See the **Synchronizing Multiple AD9951s** section of this document for details.

CFR1<22>: Software Controlled Manual Synchronization Mode.

When **CFR1<22>** = 0 (*default*), the manual synchronization feature is inactive.

When **CFR1<22>** = 1, the software controlled manual synchronization feature is executed. The SYNC_CLK rising edge is advanced by one SYSCLK cycle and this bit is cleared. To advance the rising edge multiple times, this bit needs to be set for each advance. See the **Synchronizing Multiple AD9951s** section of this document

CFR1<20>: Amplitude dither enable bit.

When **CFR1<20>** = 0 (*default*), amplitude dithering is disabled.

When **CFR1<20>** = 1, amplitude dithering is enabled.

CFR1<19>: Phase bit <16> dither enable bit.

When **CFR1<19>** = 0 (*default*), phase dithering for truncated phase words, bit 16 of <31:13>, is disabled.

When **CFR1<19>** = 1, phase dithering for truncated phase words, bit 16 of <31:13>, is enabled.

CFR1<18>: Phase bit <15> dither enable bit.

When **CFR1<18>** = 0 (*default*), phase dithering for truncated phase words, bit 15 of <31:13>, is disabled.

When **CFR1<18>** = 1, phase dithering for truncated phase words, bit 15 of <31:13>, is enabled.

CFR1<17>: Phase bit <14> dither enable bit.

When **CFR1<17>** = 0 (*default*), phase dithering for truncated phase words, bit 14 of <31:13>, is disabled.

When **CFR1<17>** = 1, phase dithering for truncated phase words, bit 14 of <31:13>, is enabled.

CFR1<16>: Phase bit <13> dither enable bit.

When **CFR1<16>** = 0 (*default*), phase dithering for truncated phase words, bit 13 of <31:13>, is disabled.

When **CFR1<16>** = 1, phase dithering for truncated phase words, bit 13 of <31:13>, is enabled.
sequence indicator.

CFR1<13>: AutoClear Phase Accumulator bit.

When **CFR1<13>** = 0 (*default*), a new frequency tuning word is applied to the inputs of the phase accumulator, but not loaded into the accumulator.

When **CFR1<13>** = 1, this bit automatically synchronously clears (loads zeros into) the phase accumulator for one cycle upon reception of the I/O UPDATE sequence indicator.

CFR1<12>: Sine/Cosine select bit.

When **CFR1<12>** = 0 (*default*), the angle-to-amplitude conversion logic employs a COSINE function.

When **CFR1<12>** = 1, the angle-to-amplitude conversion logic employs a SINE function.

CFR1<10>: Clear Phase Accumulator.

When **CFR1<10>** = 0 (*default*), the phase accumulator functions as normal.

When **CFR1<10>** = 1, the phase accumulator memory elements are asynchronously cleared and held clear until this bit is set back to zero.

CFR1<9>: SDIO Input Only.

When **CFR1<9>** = 0 (*default*), the SDIO pin has bi-directional operation (2-wire serial programming mode).

When **CFR1<9>** = 1, the serial data I/O pin (SDIO) is configured as an input only pin (3-wire serial programming mode).

CFR1<8>: LSB First.

When **CFR1<8>** = 0 (*default*), MSB first format is active.

When **CFR1<8>** = 1, the serial interface accepts serial data in LSB first format.

CFR1<7>: Digital Power Down bit.

When **CFR1<7>** = 0 (*default*), all digital functions and clocks are active.

When **CFR1<7>** = 1, all non-IO digital functionality is suspended and all heavily loaded clocks are stopped. This bit is intended to lower the digital power to nearly zero, without shutting down the PLL clock multiplier function or the DAC.

CFR1<5>: DAC Power Down bit.

When **CFR1<5>** = 0 (*default*), the DAC is enabled for operation.

When **CFR1<5>** = 1, the DAC is disabled and is in its lowest power dissipation state.

CFR1<4>: Clock Input Power Down bit.

When **CFR1<4>** = 0 (*default*), the clock input circuitry is enabled for operation.

When **CFR1<4>** = 1, the clock input circuitry is disabled and the device is in its lowest power dissipation state.

CFR1<3>: External Power Down Mode.

When **CFR1<3>** = 0 (*default*) the external power down mode selected is the “fast recovery power down” mode. In this mode, when the PwrDwnCtl input pin is high, the digital logic and the DAC digital logic are powered down. The DAC bias circuitry, PLL, oscillator, and clock input circuitry is NOT powered down.

When **CFR1<3>** = 1, the external power down mode selected is the “full power down” mode. In this mode, when the PwrDwnCtl input pin is high, all functions are powered down. This includes the DAC and PLL, which take a significant amount of time to power up.

CFR1<1>: SyncClk Disable bit.

When **CFR1<1>** = 0 (*default*), the SyncClk pin is active.

When **CFR1<1>** = 1, the SyncClk pin assumes a static logic 0 state (disabled). In this state the pin drive logic is shut down to keep noise generated by the digital circuitry at a minimum. However, the synchronization circuitry remains active (internally) to maintain normal device timing.

CFR1<0>: Not used. Leave at 0.

NOTE: Assertion of this bit may cause the SyncClk pin to momentarily stop generating a Sync Clock signal. The device will not be operational during the re-synchronization period.

Control Function Register #2 (CFR2)

The CFR2 is comprised of three bytes located in parallel addresses 06h-04h. The CFR2 is used to control the various functions, features, and modes of the AD9951, primarily related to the analog sections of the chip. All bits of the CFR2 will be routed directly to the Analog section of the AD9951 as a single 24-bit bus labeled CFR2<23:0>.

CFR2<15:12>: Not Used.

CFR2<11>: High Speed Sync Enable bit.

When **CFR2<11>** = 0 (*default*) the High Speed Sync enhancement is off.

When **CFR2<11>** = 1, the High Speed Sync enhancement is on. See the **Synchronizing Multiple AD9951s** section of this document for details.

CFR2<10>: Hardware Manual Sync Enable bit.

When **CFR2<10>** = 0 (*default*) the Hardware Manual Sync function is off.

When **CFR2<11>** = 1, the Hardware Manual Sync function is enabled. While this bit is set, a rising edge on the SYNC_IN pin will cause the device to advance the SYNC_CLK rising edge by one REFCLK cycle. Unlike the software manual sync enable bit, this bit does not self-clear. Once the hardware manual sync mode is enabled, it will stay enabled until this bit is cleared. See the **Synchronizing Multiple AD9951s** section of this document for details.

CFR2<9>: Crystal Out Enable bit.

When **CFR2<9>** = 0 (*default*) the Crystal Out pin is inactive.

When **CFR2<9>** = 1, the Crystal Out pin is active. When active, the crystal oscillator circuitry output drives the Crystal Out pin, which can be connected to other devices to produce a reference frequency.

CFR2<8>: DAC prime data disable bit.

When **CFR2<8>** = 0 (*default*), the DAC prime data is enabled for operation.

When **CFR2<8>** = 1, the DAC prime data is not generated and these outputs remain logic zeros.

CFR2<7:3>: Reference clock multiplier control bits. See the **Phase Locked Loop (PLL)** section of this document for details.

CFR2<2>: VCO gain control bit. This bit is used to control the gain setting on the VCO.

CFR<1:0>: Charge Pump gain control bits. These bits are used to control the gain setting on the charge pump.

Other Register Descriptions

Amplitude Scale Factor (ASF)

The ASF Register stores the 2-bit Auto Ramp Rate Speed value ASF<15:14> and the 14-bit Amplitude Scale Factor ASF<13:0> used in the Output Shaped Keying (OSK) operation. In auto OSK operation, that is CFR1<24> = 1, ASF <15:14> tells the OSK block how many amplitude steps to take for each increment or decrement. ASF<13:0> sets the maximum value achievable by the OSK internal multiplier. In manual OSK mode, that is CFR1<24>=0, ASF<15:14> have no affect. ASF <13:0> provide the output scale factor directly. If the OSK enable bit is cleared, CFR1<25>=0, this register has no affect on device operation.

Amplitude Ramp Rate (ARR)

The ARR register stores the 8-bit Amplitude Ramp Rate used in the Auto OSK mode, that is CFR1<25>=1, CFR<24>=1. This register programs the rate the amplitude scale factor counter increments or decrements. In the OSK is set to manual mode, CFR1<25>=1 CFR<24>=0, or if OSK enable is cleared CFR1<25>=0, this register has no affect on device operation.

Frequency Tuning Word 0 (FTW0)

The Frequency Tuning Word is a 32-bit register that controls the rate of accumulation in the phase accumulator of the DDS core. Its specific role is dependent on the device mode of operation.

Phase Offset Word (POW)

The Phase Offset Word is a 14-bit register that stores a phase offset value. This offset value is added to the output of the phase accumulator to offset the current phase of the output signal. The exact value of phase offset is given by the following formula: $\Phi = \left(\frac{POW}{2^{14}} \right) * 360^\circ$

Mode of Operation

Single Tone Mode

In single tone mode, the DDS core uses a single tuning word. Whatever value is stored in FTW0 is supplied to the phase accumulator. This value can only be changed statically, which is done by writing a new value to FTW0 and issuing an I/O UPDATE. Phase adjustment is possible through the phase offset register.

Continuous Clear and “Clear and Release” Phase Accumulator Clear Functions

The AD9951 allows for a programmable continuous zeroing of the phase accumulator as well as a “clear and release”, or automatic zeroing function. Each feature is individually controlled via bits the CFR1. CFR1<13> is the Automatic Clear Phase Accumulator bit. CFR1<10> clears the Phase Accumulator.

Continuous Clear bits

The continuous clear bits are simply static control signals that, when active high, hold the respective accumulator at zero for the entire time the bit is active. When the bit goes low, inactive, the accumulator is allowed to operate.

Clear and Release function

The Auto Clear Phase Accumulator, when set, clears and releases the phase accumulator upon receiving an I/O UPDATE. The automatic clearing function is repeated for every subsequent I/O UPDATE until the appropriate auto-clear control bit is cleared.

Programming AD9951 Features

Phase Offset Control

A 14-bit phase-offset (θ) may be added to the output of the Phase Accumulator by means of the Control Registers. This feature provides the user with two different methods of phase control.

The first method is a static phase adjustment, where a fixed phase-offset is loaded into the appropriate phase-offset register and left unchanged. The result is that the output signal is offset by a constant angle relative to the nominal signal. This allows the user to phase align the DDS output with some external signal, if necessary.

The second method of phase control is where the user regularly UPDATES the phase-offset register via the I/O Port. By properly modifying the phase-offset as a function of time, the user can implement a phase modulated output signal. However, both the speed of the I/O Port and the frequency of sysclk limit the rate at which phase modulation can be performed.

Phase/Amplitude Dithering

The AD9951 DDS core includes optional phase and/or amplitude dithering controlled via the CFR1<20:16> bits.

Phase dithering is the randomization of the state of the least significant bits of each phase word. Phase dithering reduces spurious signal strength caused by phase truncation by spreading the spurious energy over the entire spectrum. The downside to dithering is a rise in the noise floor. Amplitude dithering is similar, except it affects the output signal routed to the DAC.

Phase dithering is independently controlled on the four least significant bits of the phase word routed to the angle rotation function. That is, any or all of the phase word four least significant bits may be dithered or not dithered, controlled by the user via the serial port. Specifically, the CFR1<19> bit controls the phase dithering enable function of the phase word <16> bit. The CFR1<18> bit controls the phase dithering enable function of the phase word <15> bit. The CFR1<17> bit controls the phase dithering enable function of the phase word <14> bit. The CFR1<16> bit controls the phase dithering enable function of the phase word <13> bit. This enable function is such that if the bit is high, dithering is enabled. If the bit is low, dithering is not enabled.

Amplitude dithering uses one control bit to enable or disable dithering. If the amplitude dither enable bit (CFR1<20>) is logic 0, no amplitude dithering is enabled and the data from the DDS core is passed unchanged. When high, amplitude dithering is enabled.

Shaped On-Off Keying

General Description: The Shaped On-Off keying function of the AD9951 allows the user to control the ramp-up and ramp-down time of an “on-off” emission from the DAC. This function is used in “burst transmissions” of digital data to reduce the adverse spectral impact of short, abrupt bursts of data.

AUTO and MANUAL Shaped On-Off Keying modes are supported. The AUTO mode generates a linear scale factor at a rate determined by the Amplitude Ramp Rate (ARR) Register controlled by an external pin (OSK). MANUAL mode allows the user to directly control the output amplitude by writing the scale factor value into the Amplitude Scale Factor (ASF) Register (ASF).

The Shaped On-Off keying function may be bypassed (disabled) by clearing the OSK Enable bit (CFR1<25>=0).

The modes are controlled by two bits located in the most significant byte of the Control Function Register (CFR). CFR1<25> is the Shaped On-Off Keying enable bit. When CFR1<25> is set, the output scaling function is enabled; CFR1<25> bypasses the function. CFR1<24> is the internal Shaped On-Off Keying active bit. When CFR1<24> is set, internal Shaped On-Off Keying mode is active; CFR1<24> cleared is external Shaped On-Off Keying mode active. CFR1<24> is a “Don’t care” if the Shaped On-Off Keying enable bit (CFR1<25>) is cleared. The power up condition is

Shaped On-Off Keying disabled (CFR1<25> = 0). Figure C below shows the block diagram of the OSK circuitry.

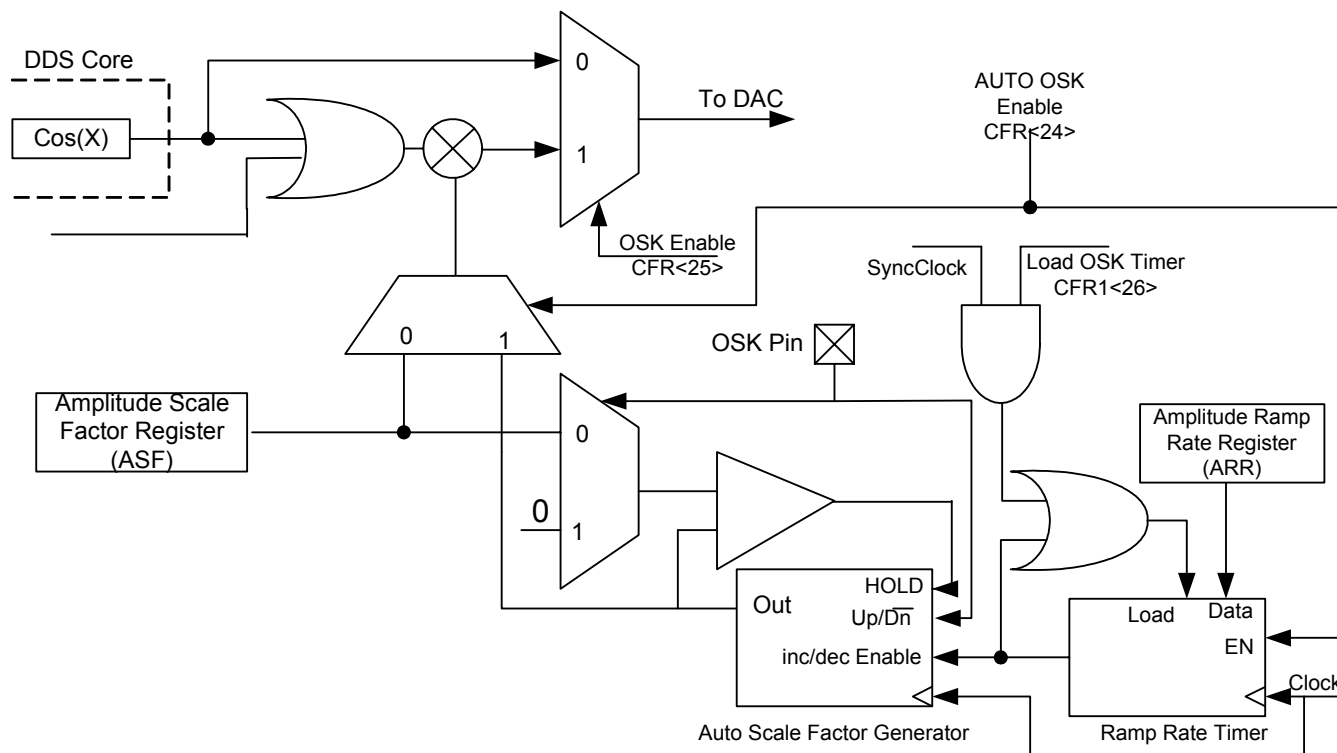

Figure C. On-Off Shaped Keying, Block Diagram

AUTO Shaped On-Off Keying mode operation:

The AUTO Shaped On-Off Keying mode is active when CFR1<25> and CFR1<24> are set. When AUTO Shaped On-Off Keying mode is enabled, a single scale factor is internally generated and applied to the multiplier input for scaling the output of the DDS core block (See Figure 9 above). The scale factor is the output of a 14-bit counter which increments/decrements at a rate determined by the contents of the 8-bit output ramp rate register. The scale factor increases if the OSK pin is high, decreases if the pin is low. The scale factor is an unsigned value such that all zeros multiplies the DDS core output by 0 (decimal) and 3FFFh multiplies the DDS core output by 16383 decimal.

For those users who use the full amplitude (14-bits) but need fast ramp rates, the internally generated scale factor step size is controlled via the ASF<15:14> bits. The table below describes the increment/decrement step size of the internally generated scale factor per the ASF<15:14> bits.

ASF<15:14> (binary)	Increment/decrement size
00	1
01	2
10	4
11	8

Table 5 Auto-Scale Factor Internal Step Size

A special feature of this mode is that the maximum output amplitude allowed is limited by the contents of the Amplitude Scale Factor Register. This allows the user to ramp to a value less than full scale.

OSK Ramp Rate Timer

The OSK ramp rate timer is a loadable down counter, which generates the clock signal to the 14-bit counter that generates the internal scale factor. The ramp rate timer is loaded with the value of the ASFR every time the counter reaches 1 (decimal). This load and count down operation continues for as long as the timer is enabled unless the timer is forced to load before reaching a count of 1.

If the Load OSK Timer bit (CFR1<26>) is set, the ramp rate timer is loaded upon an I/O UPDATE or upon reaching a value of 1. The ramp timer can be loaded before reaching a count of 1 by three methods.

Method one is by changing the OSK input pin. When the OSK input pin changes state the ASFR value is loaded into the ramp rate timer, which then proceeds to count down as normal.

The second method in which the sweep ramp rate timer can be loaded before reaching a count of 1 is if the Load OSK Timer bit (CFR1<26>) bit is set and an I/O UPDATE is issued.

The last method in which the sweep ramp rate timer can be loaded before reaching a count of 1 is when going from the inactive AUTO Shaped On-Off Keying mode to the active AUTO Shaped On-Off Keying mode. That is, when the sweep enable bit is being set.

External Shaped On-Off Keying mode operation:

The external Shaped On-Off Keying mode is enabled by writing CFR1<25> to a logic 1 AND writing CFR1<24> to a logic 0. When configured for external Shaped On-Off Keying, the content of the ASFR becomes the scale factor for the data path. The scale factors are synchronized to dds_Clock via the I/O UPDATE functionality.

Functionality of the SyncClk and I/O UPDATE

Data into the AD9951 is synchronous to the **SyncClk** pin. That is, the **I/O UPDATE** pin is sampled on the rising edge of the SyncClk clock provided by the AD9951.

As shown in the Figure D, sysclk is fed to a divide-by-4 frequency divider to produce sync_clk which is also provided to the user on the **SyncClk** pin. This enables synchronization of external hardware with the AD9951's internal DDS clock. This is accomplished by forcing any external hardware to obtain its timing from SyncClk. External hardware that is timed using the SyncClk signal can then be used to provide the I/O UPDATE (Frequency UPDATE) signal to the AD9951. The I/O UPDATE signal coupled with SyncClk is used to transfer internal buffer register contents into the Control Registers of the device. The combination of the SyncClk and I/O UPDATE pins provides the user with constant latency relative to sysclk and also ensures phase continuity of the analog output signal when a new tuning word or phase offset value is asserted. Figure E demonstrates an I/O Update timing cycle and synchronization.

Notes to synchronization logic:

- 1) The I/O UPDATE signal is edge detected to generate a single rising edge clock signal that drives the register bank flops. The I/O UPDATE signal has no constraints on duty cycle. The minimum low time on I/O UPDATE is one sync_clk clock cycle.
- 2) The I/O UPDATE pin is setup and held around the rising edge of sync_clk and has zero hold time and 10ns setup time.

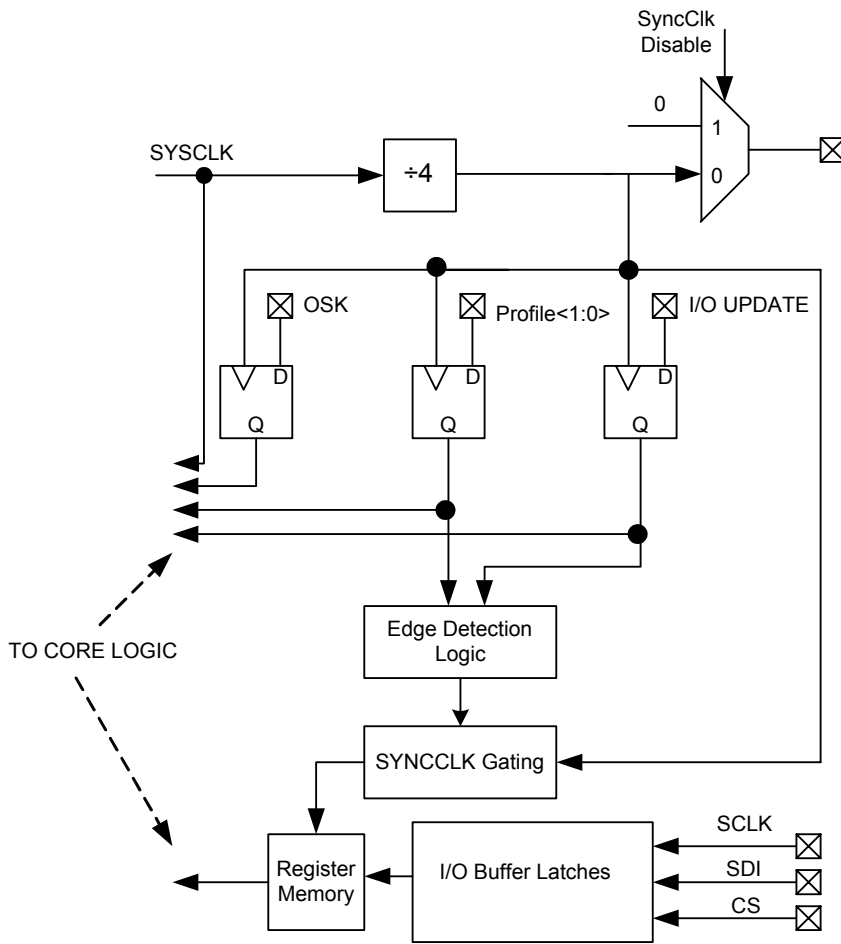
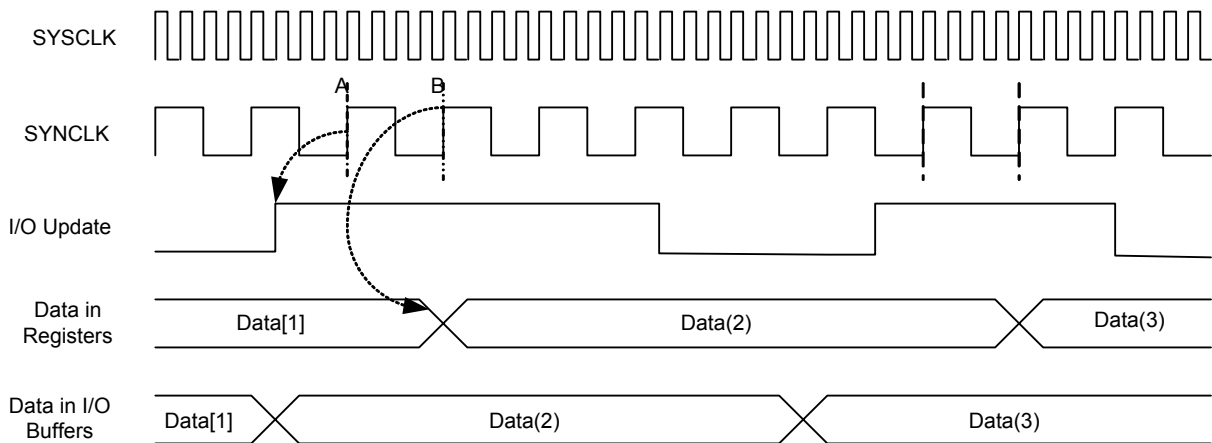

Figure D- I/O Synchronization Block Diagram



The device registers an I/O Update at point A. The data is transferred from the asynchronously loaded I/O buffers at point B.

Figure E - I/O Synchronization Timing Diagram

The AD9951 product allows easy synchronization of multiple AD9951s. There are three modes of synchronization available to the user: an automatic synchronization mode; a software controlled manual synchronization mode; and a hardware controlled manual synchronization mode. In all cases, when a user wants to synchronize two or more devices, the following considerations must be observed. First, all units must share a common clock source. Trace lengths and path impedance of the clock tree must be designed to keep the phase delay of the different clock branches as closely matched as possible. Second, the I/O update signal's rising edge must be provided synchronously to all devices in the system. Finally, regardless of the internal synchronization method used, the DVDD_I/O supply should be set to 3.3V for all devices that are to be synchronized. AVDD and DVDD should be left at 1.8V.

In automatic synchronization mode, one device is chosen as a master, the other device(s) will be slaved to this master. When configured in this mode, all the slaves will automatically synchronize their internal clocks to the sync_clk output signal of the master device. To enter automatic synchronization mode, set the slave device's automatic synchronization bit (CFR1<23>=1). Connect the SYNC_IN input(s) to the master SYNC_CLK output. The slave device will continuously update the phase relationship of its sync_clk until it is in phase with the SYNC_IN input, which is the sync_clk of the master device. When attempting to synchronize devices running at sysclk speeds beyond 250MSPS, the high-speed sync enhancement enable bit should be set (CFR2<11>=1).

In software manual synchronization mode, the user forces the device to advance the sync_clk rising edge one sysclk cycle (1/4 sync_clk period). To activate the manual synchronization mode, set the slave device's software manual synchronization bit (CFR1<22>=1). The bit (CFR1<22>) will be immediately cleared. To advance the rising edge of the sync_clk multiple times, this bit will need to be set multiple times.

In hardware manual synchronization mode, the SYNC_IN input pin is configured such that it will now advance the rising edge of the sync_clk signal each time the device detects a rising edge on the SYNC_IN pin. To put the device into hardware manual synchronization mode, set the hardware manual synchronization bit (CFR2<10>=1). Unlike the software manual synchronization bit, this bit does not self-clear. Once the hardware manual synchronization mode is enabled, all rising edges detected on the SYNC_IN input will cause the device to advance the rising edge of the sync_clk by one sysclk cycle until this enable bit is cleared (CFR2<10>=0).

Using a Single Crystal To Drive Multiple AD9951 Clock Inputs

The AD9951 crystal oscillator output signal is available on the CrystalOut pin, enabling one crystal to drive multiple AD9951s. In order to drive multiple AD9951s with one crystal, the CrystalOut pin of the AD9951 using the external crystal should be connected to the REFCLK input of the other AD9951.

The CrystalOut pin is static until the CFR2<1> bit is set, enabling the output. The drive strength of the CrystalOut pin is typically very low, so this signal should be buffered prior to using it to drive any loads.

Serial Port Operation

With the AD9951, the Instruction Byte specifies read/write operation and register address. Serial operations on the AD9951 occur only at the register level, not the byte level. For the AD9951, the serial port controller recognizes the Instruction Byte register address and automatically generates the proper register byte address. In addition, the controller expects that all bytes of that register will be accessed. **It is a requirement that all bytes of a register be accessed during serial I/O operations**, with one exception. The SYNCIO function can be used to abort an IO operation thereby allowing less than all bytes to be accessed.

There are two phases to a communication cycle with the AD9951. Phase 1 is the instruction cycle, which is the writing of an instruction byte into the AD9951, coincident with the first eight SCLK rising edges. The instruction byte provides the AD9951 serial port controller with information regarding the data transfer cycle, which is Phase 2 of the communication cycle. The Phase 1 instruction byte defines whether the upcoming data transfer is read or write and the serial address of the register being accessed. [Note – the serial address of the register being accessed is NOT the same address as the bytes to be written. See the Example Operation section below for details].

The first eight SCLK rising edges of each communication cycle are used to write the instruction byte into the AD9951. The remaining SCLK edges are for Phase 2 of the communication cycle. Phase 2 is the actual data transfer between the AD9951 and the system controller. The number of bytes transferred during Phase 2 of the communication cycle is a function of the register being accessed. For example, when accessing the Control Function Register 2, which is three bytes wide, Phase 2 requires that three bytes be transferred. If accessing the Frequency Tuning Word, which is four bytes wide, Phase 2 requires that four bytes be transferred. After transferring all data bytes per the instruction, the communication cycle is completed.

At the completion of any communication cycle, the AD9951 serial port controller expects the next 8 rising SCLK edges to be the instruction byte of the next communication cycle. All data input to the AD9951 is registered on the rising edge of SCLK. All data is driven out of the AD9951 on the falling edge of SCLK. Figures 34 - 37 are useful in understanding the general operation of the AD9951 Serial Port.

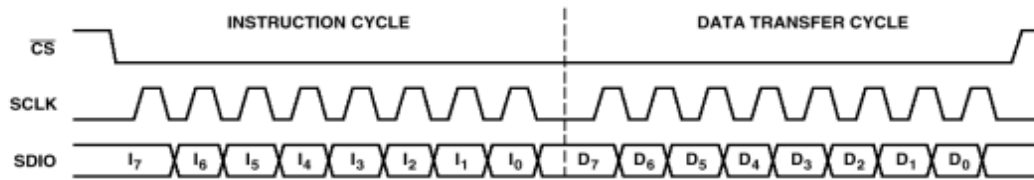

Figure 34. Serial Port Writing Timing—Clock Stall Low

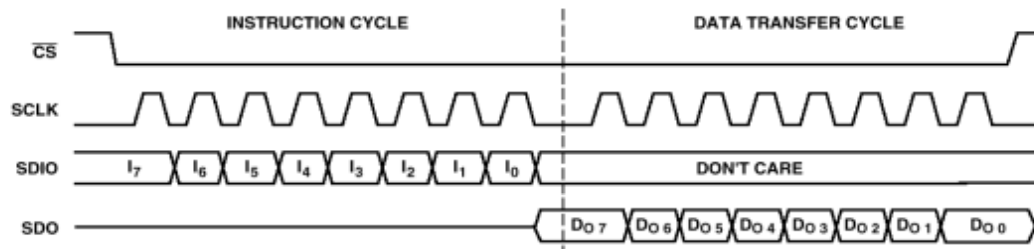

Figure 35. Three-Wire Serial Port Read Timing—Clock Stall Low

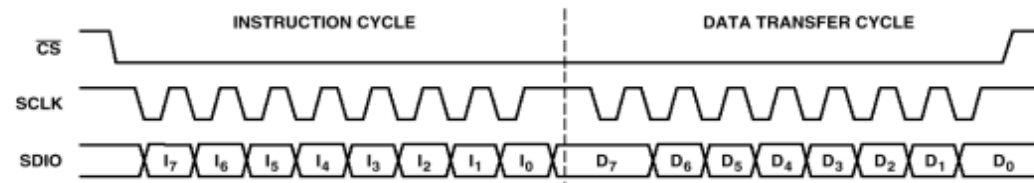

Figure 36. Serial Port Write Timing—Clock Stall High

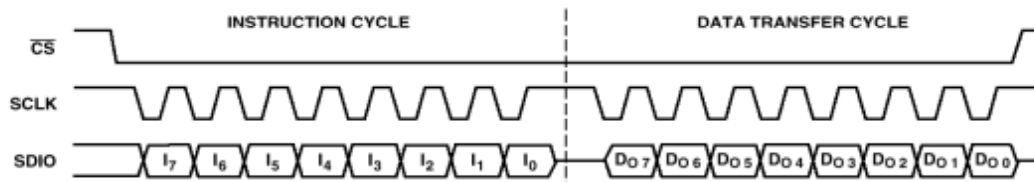

Figure 37. Two-Wire Serial Port Read Timing—Clock Stall High

Instruction Byte

The instruction byte contains the following information as shown in the table below:

Instruction Byte Information

MSB	D6	D5	D4	D3	D2	D1	LSB
R/Wb	X	x	A4	A3	A2	A1	A0

Table 6 Instruction Byte

R/-Wb—Bit 7 of the instruction byte determines whether a read or write data transfer will occur after the instruction byte write. Logic high indicates read operation. Logic zero indicates a write operation.

X, X—Bits 6 and 5 of the instruction byte are don't care.

A4, A3, A2, A1, A0—Bits 4, 3, 2, 1, 0 of the instruction byte determine which register is accessed during the data transfer portion of the communications cycle.

Serial Interface Port Pin Description

SCLK — Serial Clock. The serial clock pin is used to synchronize data to and from the AD9951 and to run the internal state machines. SCLK maximum frequency is 25 MHz.

CSB — Chip Select Bar. Active low input that allows more than one device on the same serial communications line. The SDO and SDIO pins will go to a high impedance state when this input is high. If driven high during any communications cycle, that cycle is suspended until CS is reactivated low. Chip Select can be tied low in systems that maintain control of SCLK.

SDIO — Serial Data I/O. Data is always written into the AD9951 on this pin. However, this pin can be used as a bi-directional data line. Bit 7 of register address 0h controls the configuration of this pin. The default is logic zero, which configures the SDIO pin as bi-directional.

SDO — Serial Data Out. Data is read from this pin for protocols that use separate lines for transmitting and receiving data. In the case where the AD9951 operates in a single bi-directional I/O mode, this pin does not output data and is set to a high impedance state.

SYNCIO — Synchronizes the I/O port state machines without affecting the addressable registers contents. An active high input on the SYNC I/O pin causes the current communication cycle to abort. After SYNC I/O returns low (Logic 0) another communication cycle may begin, starting with the instruction byte write.

MSB/LSB Transfers

The AD9951 serial port can support both most significant bit (MSB) first or least significant bit (LSB) first data formats. This functionality is controlled by the Control Register 00h<8> bit. The default value of Control Register 00h<8> is low (MSB first). When Control Register 00h<8> is set high, the AD9951 serial port is in LSB first format. The instruction byte must be written in the format indicated by Control Register 00h<8>. That is, if the AD9951 is in LSB first mode, the instruction byte must be written from least significant bit to most significant bit.

For MSB first operation, the serial port controller will generate the most significant byte (of the specified register) address first followed by the next lesser significant byte addresses until the IO operation is complete. All data written to (read from) the AD9951 must be (will be) in MSB first order. If the LSB mode is active, the serial port controller will generate the least significant byte address first followed by the next greater significant byte addresses until the IO operation is complete. All data written to (read from) the AD9951 must be (will be) in LSB first order.

Example Operation

To write the Amplitude Scale Factor register in MSB first format apply an instruction byte of 02h (serial address is 00010(b)). From this instruction, the internal controller will generate an internal byte address of 07h (see the register map) for the first data byte written and an internal address of 08h for the next byte written. Since the Amplitude Scale Factor register is two bytes wide, this ends the communication cycle.

To write the Amplitude Scale Factor register in LSB first format apply an instruction byte of 40h. From this instruction, the internal controller will generate an internal byte address of 07h (see the register map) for the first data byte written and an internal address of 08h for the next byte written. Since the Amplitude Scale Factor register is two bytes wide, this ends the communication cycle.

Notes on Serial Port Operation

- 1) The AD9951 serial port configuration bits reside in bits 8 and 9 of CFR1 (address 00h). The configuration changes immediately upon writing to this register. For multi-byte transfers, writing to this register may occur during the middle of a communication cycle. Care must be taken to compensate for this new configuration for the remainder of the current communication cycle.
- 2) The system must maintain synchronization with the AD9951 or the internal control logic will not be able to recognize further instructions. For example, if the system sends an instruction byte that describes writing a 2-byte register, then pulses the SCLK pin for a 3-byte write (24 additional SCLK rising edges), communication synchronization is lost. In this case, the first 16 SCLK rising edges after the instruction cycle will properly write the first two data bytes into the AD9951, but the next eight rising SCLK edges are interpreted as the next instruction byte, not the final byte of the previous communication cycle. In the case where synchronization is lost between the system and the AD9951, the SYNC I/O pin provides a means to re-establish synchronization without re-initializing the entire chip. The SYNC I/O pin enables the user to reset the AD9951 state machine to accept the next eight SCLK rising edges to be coincident with the instruction phase of a new communication cycle. By applying and removing a “high” signal to the SYNC I/O pin, the AD9951 is set to once again begin performing the communication cycle in synchronization with the system. Any information that had been written to the AD9951 registers during a valid communication cycle prior to loss of synchronization will remain intact.

Power Down Functions of the AD9951

The AD9951 supports an externally controlled, or hardware, power down feature as well as the more common software programmable power down bits found in previous ADI DDS products.

The software control power down allows the DAC, PLL, Input Clock circuitry and the digital logic to be individually power down via unique control bits (CFR1<7:4>). These bits are not active when the externally controlled power down pin (PwrDwnCtl) is high. External Power Down Control is supported on the AD9951 via the PwrDwnCtl input pin. When the PwrDwnCtl input pin

is high, the AD9951 will enter a power down mode based on the CFR1<3> bit. When the PwrDwnCtl input pin is low, the external power down control is inactive.

When the CFR1<3> bit is zero, and the PwrDwnCtl input pin is high, the AD9951 is put into a “fast recovery power down” mode. In this mode, the digital logic and the DAC digital logic are powered down. The DAC bias circuitry, PLL, oscillator, and clock input circuitry is NOT powered down.

When the CFR1<3> bit is high, and the PwrDwnCtl input pin is high, the AD9951 is put into the “full power down” mode. In this mode, all functions are powered down. This includes the DAC and PLL, which take a significant amount of time to power up.

When the PwrDwnCtl input pin is high, the individual power down bits (CFR1<7>, <5:4>) are invalid (don’t care) and are unused. When the PwrDwnCtl input pin is low, the individual power down bits control the power down modes of operation.

NOTE – The power down signals are all designed such that a logic 1 indicates the low power mode and a logic zero indicates the active, or powered up mode.

The table below indicates the logic level for each power down bit that drives out of the AD9951 core logic to the analog section and the digital clock generation section of the chip for the External Power Down operation.

Control	Mode active	Description
PwrDwnCtl = 0 CFR1<3> don’t care	Software Control	Digital power down = CFR1<7> DAC power down = CFR1<5> Input Clock power down = CFR1<4>
PwrDwnCtl = 1 CFR1<3> = 0	External Control, Fast recovery power down mode	Digital power down = 1’b1; DAC power down = 1’b0; Input Clock power down = 1’b0;
PwrDwnCtl = 1 CFR1<3> = 1	External Control, Full power down mode	Digital power down = 1’b1; DAC power down = 1’b1; Input Clock power down = 1’b1;

Table 7 Power Down Control Functions

Digital and Input Clock Power Down

The digital power down bit stops all clocks associated with the digital section of the chip. This includes the SyncClock signal. It’s important to note that when the SyncClock is stopped, the IO port cannot be updated. The figure shown below shows the logical functionality required of the digital power down bit. The power down bit can be disabled (power back on) without the need for SyncClock being activated.

AD9951 Application Suggestions

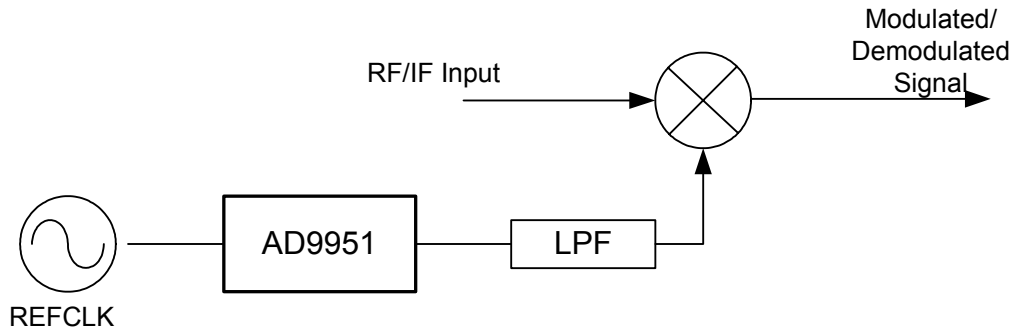

Figure F Synthesized L.O For Upconversion/DownConversion

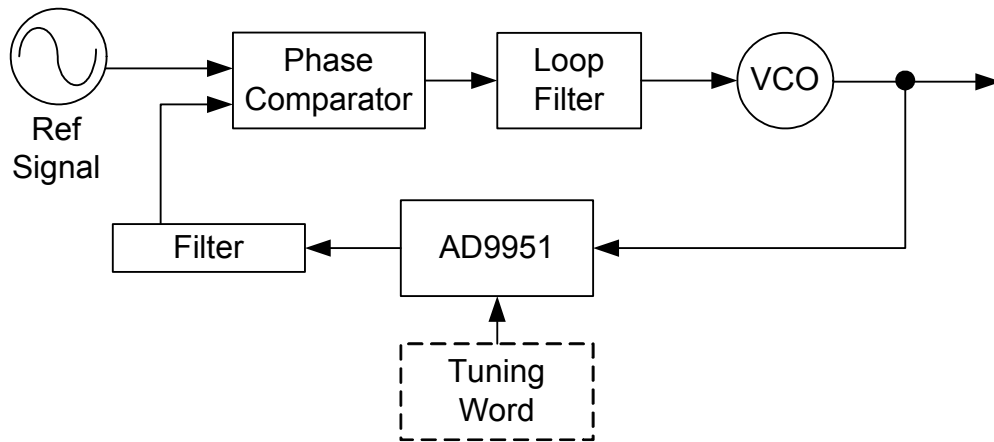

Figure G Digitally Programmable “Divide-by-N” Function in PLL

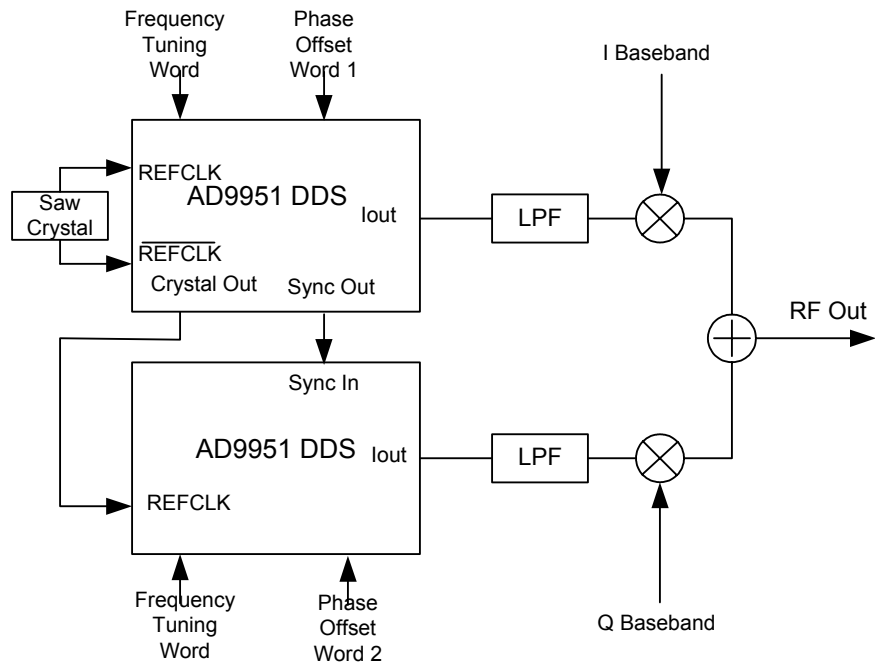

Figure H Two AD9951s Synchronized to Provide I & Q Carriers with Independent Phase Offsets for Nulling