

16 GHz INPUT DIVIDE BY 8 PRESCALER IC FOR SATELLITE COMMUNICATIONS

DESCRIPTION

The μPB1514TU is a silicon germanium (SiGe) monolithic integrated circuit designed as a divide by 8 prescaler IC for satellite communications and point-to-point/multi-point radios.

The package is 8-pin lead-less minimold suitable for surface mount.

This IC is manufactured using our 50 GHz f_{max} UHS2 (Ultra High Speed Process) SiGe bipolar process.

FEATURES

- Operating frequency : $f_{in} = 8$ to 16 GHz
- Low current consumption : $I_{cc} = 50$ mA @ $V_{cc} = 5.0$ V
- High-density surface mounting : 8-pin lead-less minimold
- Supply voltage : $V_{cc} = 4.5$ to 5.5 V
- Division ratio : 8

APPLICATIONS

- Point-to-point/Multi-point radios
- VSAT radios

ORDERING INFORMATION

Part Number	Order Number	Package	Marking	Supplying Form
μPB1514TU-E2	μPB1514TU-E2-A	8-pin lead-less minimold (Pb-Free) ^{Note}	1514	<ul style="list-style-type: none"> • 8 mm wide embossed taping • Pin 5, 6, 7, 8 indicates pull-out direction of tape • Qty 5 kpcs/reel

Note With regards to terminal solder (the solder contains lead) plated products (conventionally plated), contact your nearby sales office.

Remark To order evaluation samples, contact your nearby sales office.
Part number for sample order: μPB1514TU

Caution Observe precautions when handling because these devices are sensitive to electrostatic discharge.

The information in this document is subject to change without notice. Before using this document, please confirm that this is the latest version.
Not all devices/types available in every country. Please check with local NEC Compound Semiconductor Devices representative for availability and additional information.

INTERNAL BLOCK DIAGRAM AND PIN CONNECTIONS

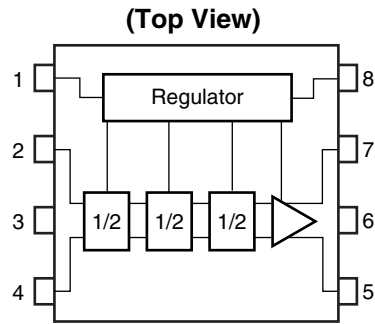

Pin No.	Pin Name
1	V _{cc1}
2	IN
3	GND
4	$\overline{\text{IN}}$
5	$\overline{\text{OUT}}$
6	GND
7	OUT
8	V _{cc2}

SYSTEM APPLICATION EXAMPLE

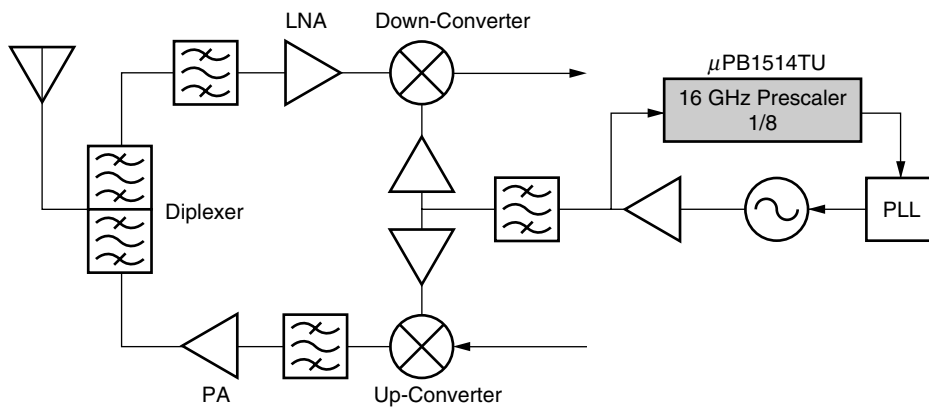

PIN EXPLANATION

Pin No.	Pin Name	Applied Voltage (V)	Function and Applications
1	V _{cc1}	5	Power supply pin. This pin must be equipped with bypass capacitor (example : 100 pF and 10 nF) to minimize ground impedance.
2	IN	–	Signal input pin. This pin should be coupled to signal source with capacitor (example : 100 pF) for DC cut.
3	GND	0	Ground pin. Ground pattern on the board should be formed as widely as possible to minimize ground impedance.
4	$\overline{\text{IN}}$	–	Signal input bypass pin. This pin must be equipped with bypass capacitor (example : 100 pF) to minimize ground impedance.
5	$\overline{\text{OUT}}$	–	Divided frequency output pin. This pin should be coupled to load device with capacitor (example : 100 pF) for DC cut.
6	GND	0	Ground pin. Ground pattern on the board should be formed as widely as possible to minimize ground impedance.
7	OUT	–	Divided frequency output pin. This pin should be coupled to load device with capacitor (example : 100 pF) for DC cut.
8	V _{cc2}	5	Power supply pin. This pin must be equipped with bypass capacitor (example : 100 pF and 10 nF) to minimize ground impedance.

ABSOLUTE MAXIMUM RATINGS

Parameter	Symbol	Test Conditions	Ratings	Unit
Supply Voltage	V _{CC}	T _A = +25°C	6	V
Total Power Dissipation	P _D	T _A = +85°C Note	867	mW
Thermal Resistance (junction to ground paddle)	R _{th(j-c)}	T _A = +85°C Note	75	°C/W
Operating Ambient Temperature	T _A		-40 to +85	°C
Storage Temperature	T _{stg}		-55 to +150	°C

Note Mounted on 33 × 21 × 0.4 mm polyimide PCB, with copper patterning on both sides.

RECOMMENDED OPERATING RANGE

Parameter	Symbol	MIN.	TYP.	MAX.	Unit
Supply Voltage	V _{CC}	4.5	5.0	5.5	V
Operating Ambient Temperature	T _A	-40	+25	+85	°C

ELECTRICAL CHARACTERISTICS (V_{CC} = 4.5 to 5.5 V, T_A = -40 to +85°C, Z_s = Z_L = 50 Ω)

Parameter	Symbol	Test Conditions	MIN.	TYP.	MAX.	Unit
Circuit Current	I _{CC}	No Signals	-	50	75	mA
Input Sensitivity	P _{in1}	f _{in} = 8 to 13.5 GHz	-2	-	+6	dBm
	P _{in2}	f _{in} = 13.5 to 16 GHz	-5	-	+6	dBm
Output Power	P _{out}	f _{in} = 8 to 16 GHz, P _{in} = 0 dBm	-11	-5	+2	dBm

TYPICAL CHARACTERISTICS (T_A = +25°C, unless otherwise specified)

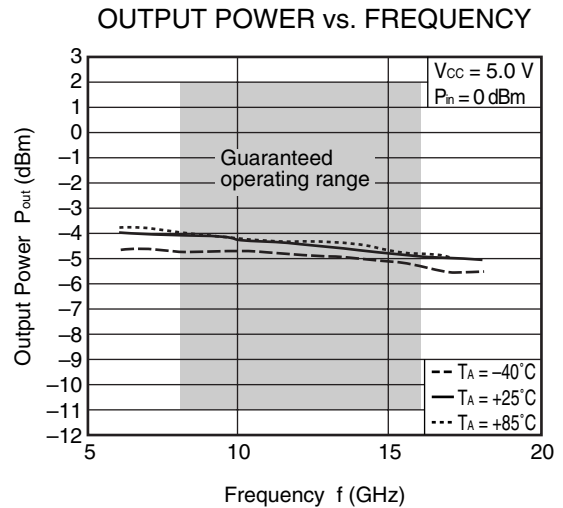
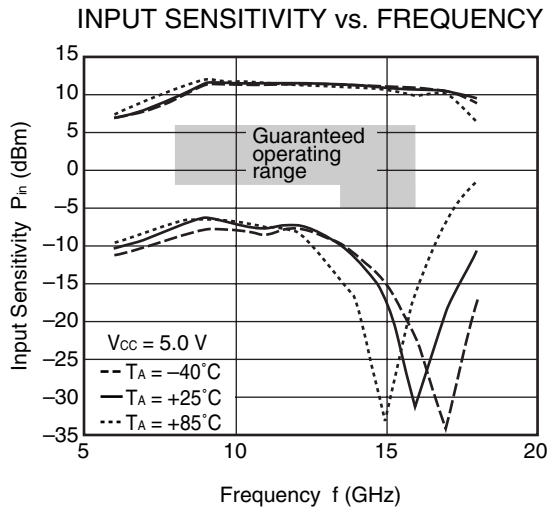
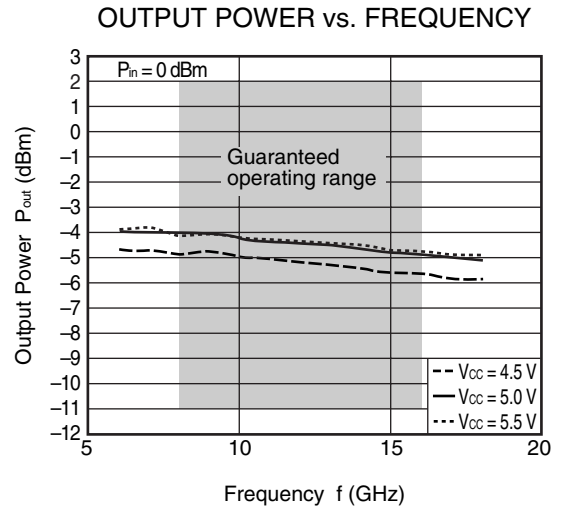
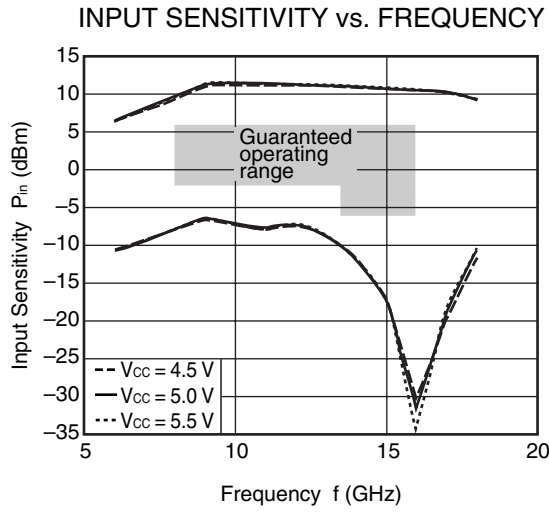

★ CIRCUIT CURRENT vs. SUPPLY VOLTAGE

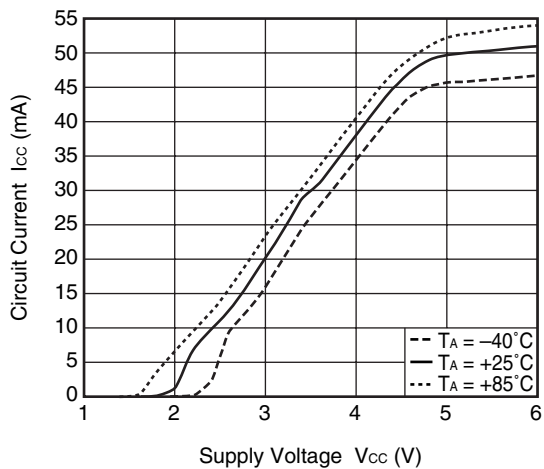

Remark The graphs indicate nominal characteristics.

★ S-PARAMETERS (T_A = +25°C, V_{CC} = 5.0 V)

S₁₁-FREQUENCY

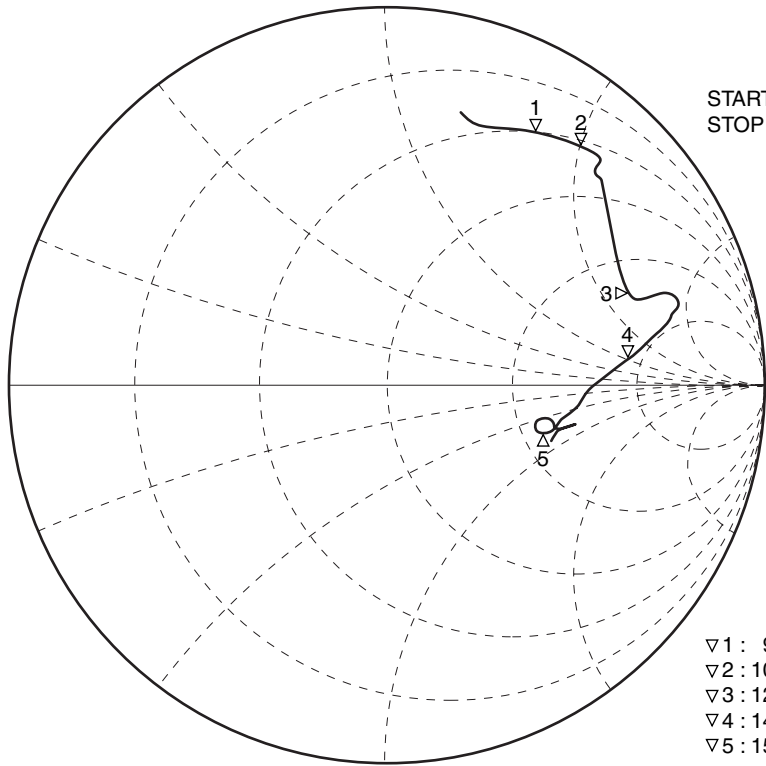

FREQUENCY GHz	MAG	S ₁₁ ANG
8.0	0.667	70.3
9.0	0.718	57.8
10.0	0.768	51.2
11.0	0.752	46.0
12.0	0.700	36.8
13.0	0.733	38.1
14.0	0.779	34.0
15.0	0.726	27.6
16.0	0.705	20.0

S₂₂-FREQUENCY

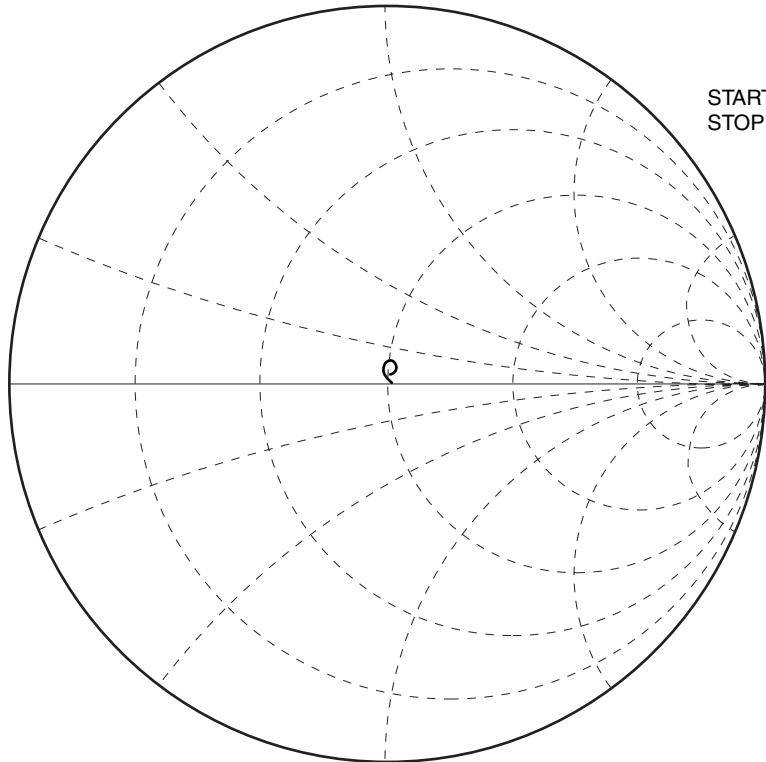

FREQUENCY GHz	MAG	S ₂₂ ANG
1.0	0.011	18.3
1.1	0.009	51.4
1.2	0.012	88.8
1.3	0.018	99.5
1.4	0.026	105.6
1.5	0.034	106.6
1.6	0.045	103.7
1.7	0.053	99.1
1.8	0.063	89.9
1.9	0.064	80.5
2.0	0.028	60.9

MEASUREMENT CIRCUIT

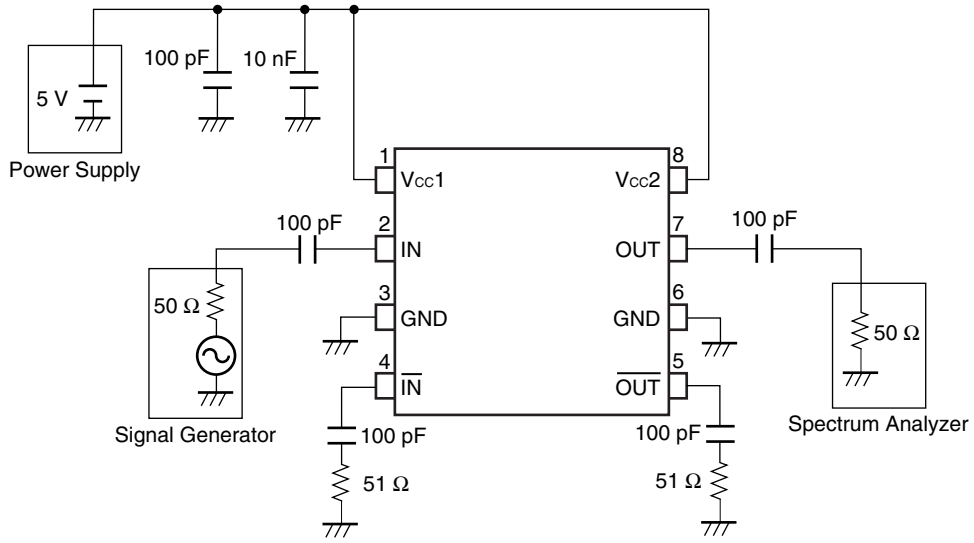

The application circuits and their parameters are for reference only and are not intended for use in actual design-ins.

ILLUSTRATION OF THE MEASUREMENT CIRCUIT ASSEMBLED ON EVALUATION BOARD

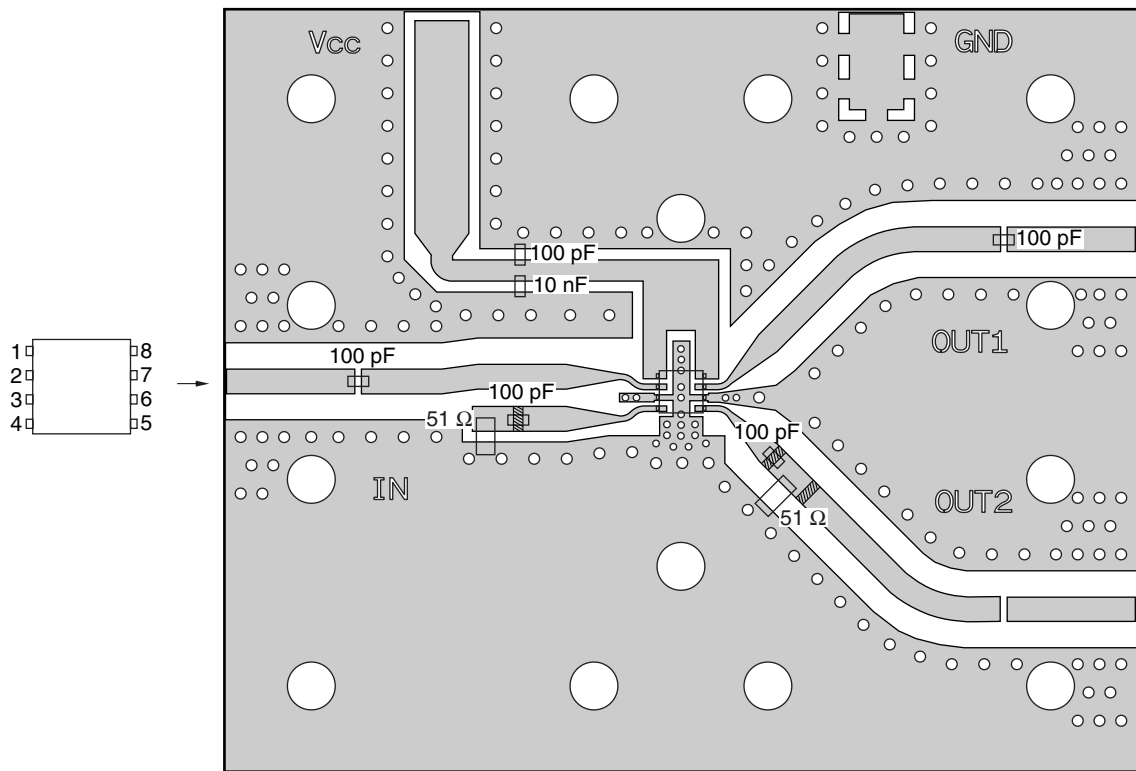

- Remarks**
1. 33 × 21 × 0.4 mm double-sided copper-clad polyimide PCB
 2. Back side: GND pattern
 3. Solder plated on pattern
 4.  represents cutout
 5. ○: Through holes

PACKAGE DIMENSIONS

8-PIN LEAD-LESS MINIMOLD (UNIT: mm)

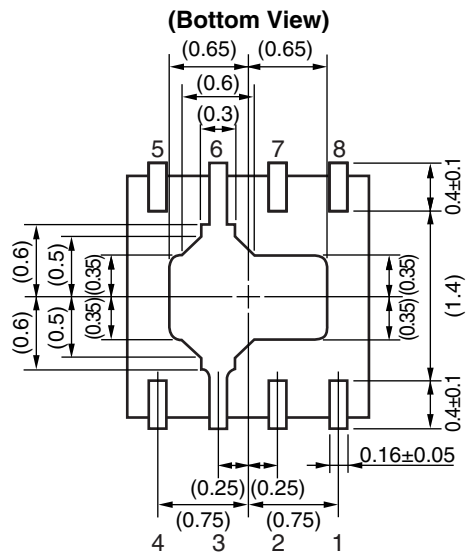
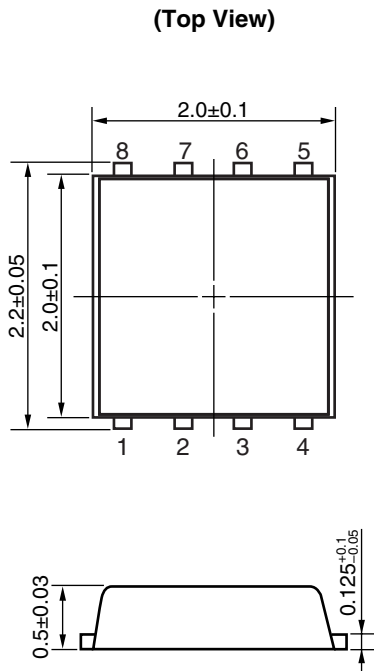

NOTES ON CORRECT USE

- (1) Observe precautions for handling because of electro-static sensitive devices.
- (2) Form a ground pattern as widely as possible to minimize ground impedance (to prevent undesired oscillation).
- (3) Keep the track length of the ground terminals as short as possible.
- (4) Bypass capacitance must be attached to V_{CC} line.
- (5) Exposed heatsink at bottom on package must be soldered to PCB RF/DC ground.

RECOMMENDED SOLDERING CONDITIONS

This product should be soldered and mounted under the following recommended conditions. For soldering methods and conditions other than those recommended below, contact your nearby sales office.

Soldering Method	Soldering Conditions	Condition Symbol
Infrared Reflow	Peak temperature (package surface temperature) : 260°C or below Time at peak temperature : 10 seconds or less Time at temperature of 220°C or higher : 60 seconds or less Preheating time at 120 to 180°C : 120±30 seconds Maximum number of reflow processes : 3 times Maximum chlorine content of rosin flux (% mass) : 0.2%(Wt.) or below	IR260
Wave Soldering	Peak temperature (molten solder temperature) : 260°C or below Time at peak temperature : 10 seconds or less Preheating temperature (package surface temperature) : 120°C or below Maximum number of flow processes : 1 time Maximum chlorine content of rosin flux (% mass) : 0.2%(Wt.) or below	WS260
Partial Heating	Peak temperature (terminal temperature) : 350°C or below Soldering time (per side of device) : 3 seconds or less Maximum chlorine content of rosin flux (% mass) : 0.2%(Wt.) or below	HS350

Caution Do not use different soldering methods together (except for partial heating).

When the product(s) listed in this document is subject to any applicable import or export control laws and regulation of the authority having competent jurisdiction, such product(s) shall not be imported or exported without obtaining the import or export license.

- **The information in this document is current as of March, 2005. The information is subject to change without notice. For actual design-in, refer to the latest publications of NEC's data sheets or data books, etc., for the most up-to-date specifications of NEC semiconductor products. Not all products and/or types are available in every country. Please check with an NEC sales representative for availability and additional information.**
 - No part of this document may be copied or reproduced in any form or by any means without prior written consent of NEC. NEC assumes no responsibility for any errors that may appear in this document.
 - NEC does not assume any liability for infringement of patents, copyrights or other intellectual property rights of third parties by or arising from the use of NEC semiconductor products listed in this document or any other liability arising from the use of such products. No license, express, implied or otherwise, is granted under any patents, copyrights or other intellectual property rights of NEC or others.
 - Descriptions of circuits, software and other related information in this document are provided for illustrative purposes in semiconductor product operation and application examples. The incorporation of these circuits, software and information in the design of customer's equipment shall be done under the full responsibility of customer. NEC assumes no responsibility for any losses incurred by customers or third parties arising from the use of these circuits, software and information.
 - While NEC endeavours to enhance the quality, reliability and safety of NEC semiconductor products, customers agree and acknowledge that the possibility of defects thereof cannot be eliminated entirely. To minimize risks of damage to property or injury (including death) to persons arising from defects in NEC semiconductor products, customers must incorporate sufficient safety measures in their design, such as redundancy, fire-containment, and anti-failure features.
 - NEC semiconductor products are classified into the following three quality grades:
 "Standard", "Special" and "Specific". The "Specific" quality grade applies only to semiconductor products developed based on a customer-designated "quality assurance program" for a specific application. The recommended applications of a semiconductor product depend on its quality grade, as indicated below. Customers must check the quality grade of each semiconductor product before using it in a particular application.
 "Standard": Computers, office equipment, communications equipment, test and measurement equipment, audio and visual equipment, home electronic appliances, machine tools, personal electronic equipment and industrial robots
 "Special": Transportation equipment (automobiles, trains, ships, etc.), traffic control systems, anti-disaster systems, anti-crime systems, safety equipment and medical equipment (not specifically designed for life support)
 "Specific": Aircraft, aerospace equipment, submersible repeaters, nuclear reactor control systems, life support systems and medical equipment for life support, etc.
- The quality grade of NEC semiconductor products is "Standard" unless otherwise expressly specified in NEC's data sheets or data books, etc. If customers wish to use NEC semiconductor products in applications not intended by NEC, they must contact an NEC sales representative in advance to determine NEC's willingness to support a given application.
- (Note)
- (1) "NEC" as used in this statement means NEC Corporation, NEC Compound Semiconductor Devices, Ltd. and also includes its majority-owned subsidiaries.
 - (2) "NEC semiconductor products" means any semiconductor product developed or manufactured by or for NEC (as defined above).
- M8E 00.4-0110

► For further information, please contact

NEC Compound Semiconductor Devices, Ltd. <http://www.ncsd.necel.com/>

E-mail: salesinfo@ml.ncsd.necel.com (sales and general)

techinfo@ml.ncsd.necel.com (technical)

Sales Division TEL: +81-44-435-1588 FAX: +81-44-435-1579

NEC Compound Semiconductor Devices Hong Kong Limited

E-mail: ncsd-hk@elhk.nec.com.hk (sales, technical and general)

Hong Kong Head Office TEL: +852-3107-7303 FAX: +852-3107-7309

Taipei Branch Office TEL: +886-2-8712-0478 FAX: +886-2-2545-3859

Korea Branch Office TEL: +82-2-558-2120 FAX: +82-2-558-5209

NEC Electronics (Europe) GmbH <http://www.ee.nec.de/>

TEL: +49-211-6503-0 FAX: +49-211-6503-1327

California Eastern Laboratories, Inc. <http://www.cel.com/>

TEL: +1-408-988-3500 FAX: +1-408-988-0279