

**LED DISPLAY****LTC-4689W**  
**DATA SHEET**

<u>Rev</u>	<u>Description</u>	<u>By</u>
-	Original Spec	<u>Praphan U.</u>
A	Revise pin connection.	<u>Phanomkorn J.</u>
<b>(Above data for PD and Customer tracking only)</b>		
-	NPPR Received and Upload on OPNC	<u>Praphan U.</u>
A	Change dice from LTW-C193TS5 To LTW-C193DS5-ND2	<u>ANON</u> <u>Jan 31'2012</u>

SPEC. NO.: AS-30-883-00002D A T E : 24/AUGUST/'2007REV. NO. : APAGE NO. : 0 OF 6

**FEATURES**

- \* 0.4 inch (10.00 mm) DIGIT HEIGHT
- \* EXCELLENT CHARACTERS APPEARANCE
- \* LOW POWER REQUIREMENT
- \* HIGH BRIGHTNESS & HIGH CONTRAST
- \* WIDE VIEWING ANGLE
- \* SOLID STATE RELIABILITY
- \* **LEAD-FREE PACKAGE**(ACCORDING TO ROHS)

**DESCRIPTION**

The LTC-4689W is 0.4 inch (10.00 mm) digit height quadruple digit seven-segment display. This device is the white-color display uses InGaN White LED chips the display has a black face and white segment

**DEVICE**

<b>PART NO.</b>	<b>DESCRIPTION</b>
WHITE-COLOR	Multiplex Common Anode
LTC-4689W	

### PACKAGE DIMENSIONS

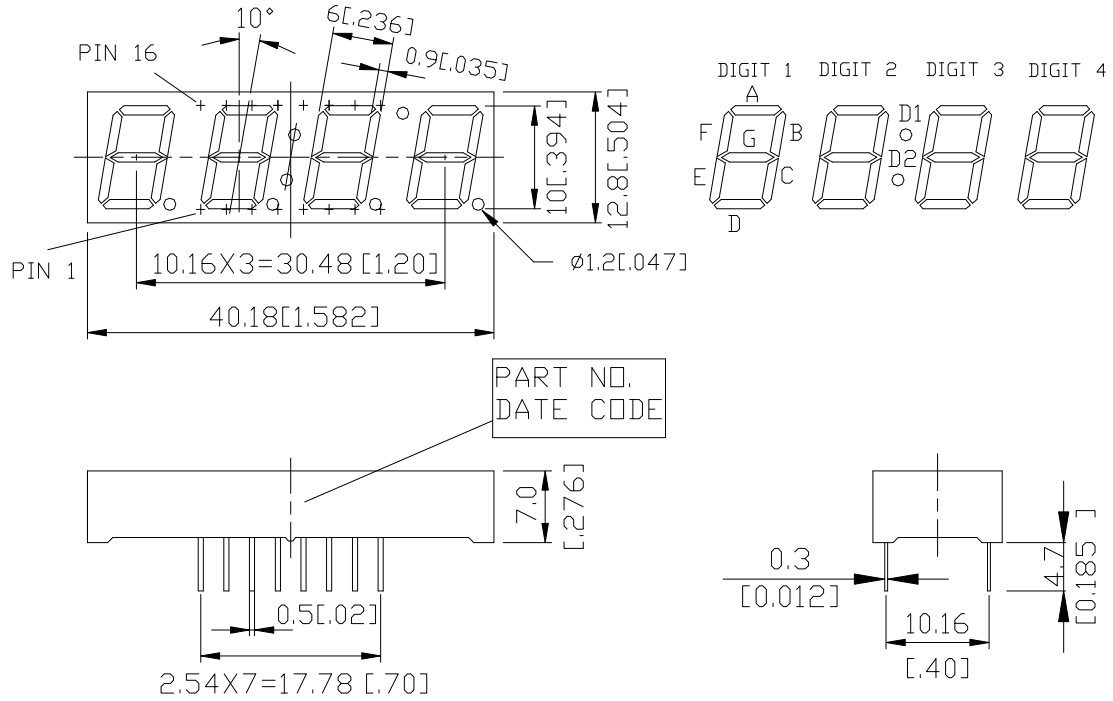

- Add protective film in display.
- Protective film specification.
  1. Dimensions: 13mm (± 0.2 mm.) x 40.18 mm (+0 / -0.2 mm.)
  2. Material: PP
  3. Temperature Range: -5 ~ 50°C

NOTES: 1. All dimensions are in millimeters. Tolerances are ± 0.25 mm “0.01” unless otherwise noted.  
 2. Pin tip’s shift tolerance is ± 0.4 mm.

### INTERNAL CIRCUIT DIAGRAM

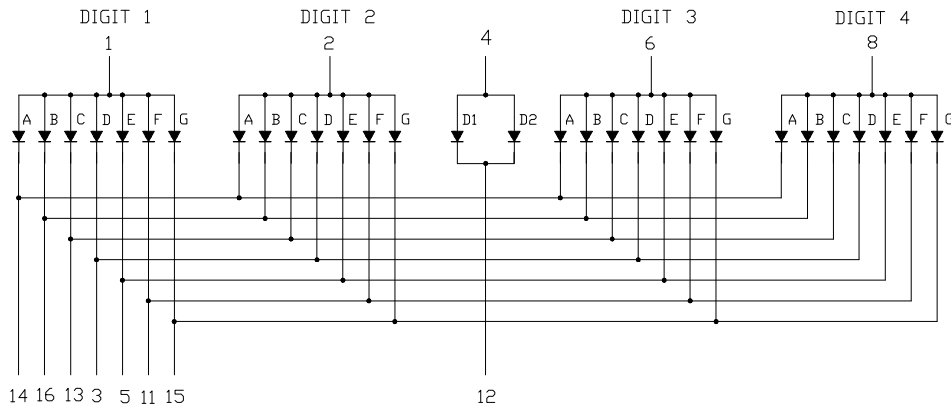

**PIN CONNECTION**

<b>No.</b>	<b>CONNECTION</b>
1	COMMON ANODE DIGIT 1
2	COMMON ANODE DIGIT 2
3	CATHODE D
4	ANODE D1, D2
5	CATHODE E
6	COMMON ANODE DIGIT 3
7	NO CONNECTION
8	COMMON ANODE DIGIT 4
9	NO CONNECTION
10	NO CONNECTION
11	CATHODE F
12	CATHODE D1, D2
13	CATHODE C
14	CATHODE A
15	CATHODE G
16	CATHODE B

**ABSOLUTE MAXIMUM RATING AT Ta = 25°C**

PARAMETER	InGaN WHITE	UNIT
Power Dissipation Per Segment	70	mW
Peak Forward Current Per Segment ( Frequency 1Khz, 10% duty cycle)	100	mA
Continuous Forward Current Per Segment	20	mA
Forward Current De rating from 25 <sup>0</sup> C	0.25	mA/°C
Reverse Voltage Per Segment	5	V
Operating Temperature Range	-35°C to +85°C	
Storage Temperature Range	-35°C to +85°C	
Soldering Conditions: 1/16 inch below seating plane for 5 seconds at 260°C or temperature of unit(during assembly) not over max. temperature rating above		
Note : max peak current at a multiplex current is 47mA (1ms on / 7ms off) @ 85°C		

**ELECTRICAL / OPTICAL CHARACTERISTICS AT Ta = 25°C**

PARAMETER	SYMBOL	MIN.	TYP.	MAX.	UNIT	TEST CONDITION
Average Luminous Intensity Per Segment	I <sub>v</sub>	5	20	40	mcd	I <sub>F</sub> =5mA
View Angle	2φ1/2		130		deg	Fig6
Average Luminous Intensity Icon ;Segment			1.2; 4		mcd/m <sup>2</sup>	I <sub>F</sub> =5mA
Chromaticity coordinates	x		0.309		nm	I <sub>F</sub> =5mA
	y		0.308			
Forward Voltage Per Chip	V <sub>F</sub>	2.70		3.15	V	I <sub>F</sub> =5mA
Reverse Current Per Chip	I <sub>R</sub>			10	μA	V <sub>R</sub> =5V

Note: 1. Luminous intensity is measured with a light sensor and filter combination that approximates the CIE (Commision Internationale De L'Eclairage) eye-response curve.

2. The chromaticity coordinates (x,y) is derived from 1931 CEI chromaticity diagram.
3. Luminous intensity tolerance +/-15%
4. Hue(x,y) tolerance +/-0.01
5. Cross talk specification ≅2.5%

**TYPICAL ELECTRICAL / OPTICAL CHARACTERISTIC CURVES**

(25°C Ambient Temperature Unless Otherwise Noted)

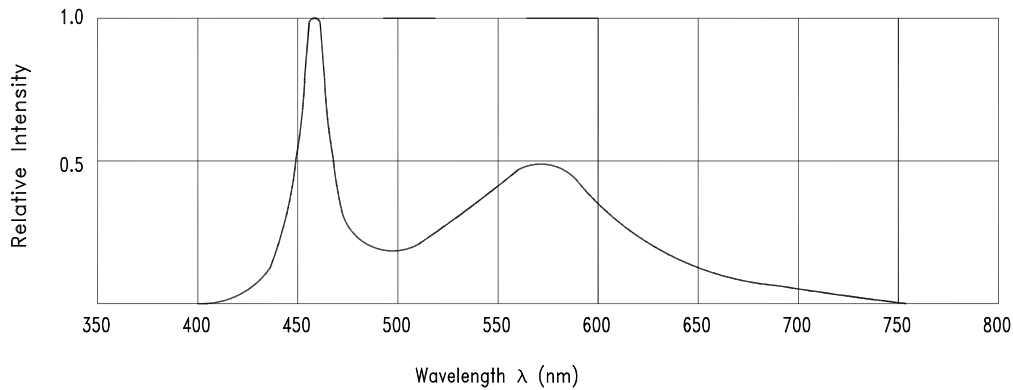

Fig.1 Relative Intensity vs. Wavelength

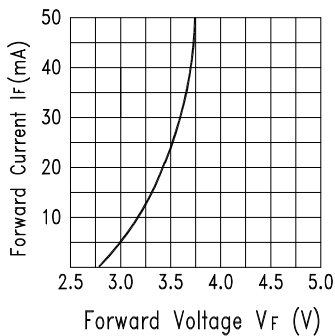

Fig.2 Forward Current vs. Forward Voltage

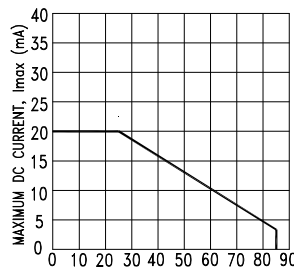

Fig.3 Forward Current Derating Curve

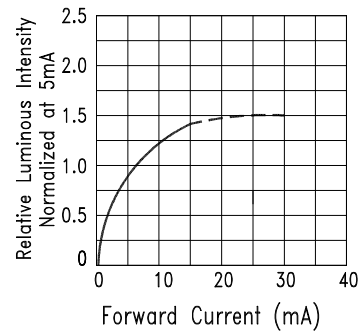

Fig.4 Relative Luminous Intensity vs. Forward Current

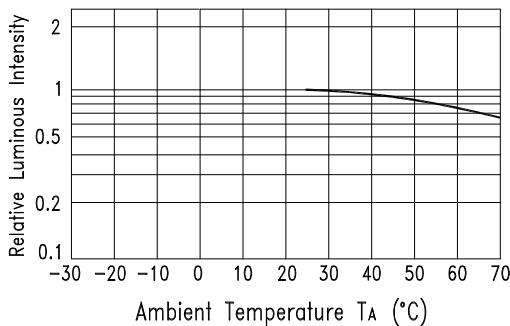

Fig.5 Luminous Intensity vs. Ambient Temperature

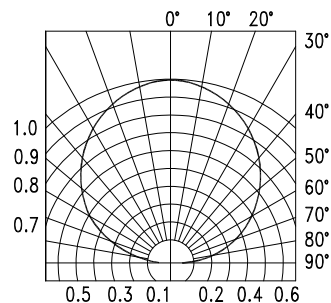

Fig.6 Spatial Distribution

#### Bin Code List

Hue Spec. Table

Hue Bin	Color bin limits at IF = 5mA				
	CIE 1931 Chromaticity coordinates				
S1-2	x	0.284	0.284	0.294	0.294
	y	0.240	0.272	0.286	0.254
S2-2	x	0.284	0.284	0.294	0.294
	y	0.272	0.305	0.319	0.286
S3-1	x	0.294	0.294	0.304	0.304
	y	0.254	0.286	0.300	0.268
S3-2	x	0.304	0.304	0.314	0.314
	y	0.268	0.300	0.315	0.282
S4-1	x	0.294	0.294	0.304	0.304
	y	0.286	0.319	0.333	0.300
S4-2	x	0.304	0.304	0.314	0.314
	y	0.300	0.333	0.347	0.315
S5-1	x	0.314	0.314	0.324	0.324
	y	0.282	0.315	0.329	0.296
S6-1	x	0.314	0.314	0.324	0.324
	y	0.315	0.347	0.361	0.329

Tolerance on each Hue (x, y) bin is +/- 0.01.

