

How To Order 233-340													
Sample Part Number	233-340				NF	00	-15	2	A	A	N	H	T
Series / Basic Part No.	SuperSeal™ USB 2.0 Connector												
Finish	NF = Cadmium Olive Drab ME = Electroless Nickel MT = Nickel PTFE												
Connector Style*	00 = Wall Mount Receptacle with Slotted Holes 07 = Jam Nut Receptacle G6 = Plug												
Shell Size	15												
USB Performance	2 = USB 2.0												
USB Back Interface	A = USB Type A Interface												
USB Front Interface	A = USB Type A Interface												
Alternate Key Position	A, B, C, D, E, N = Normal; Per MIL-DTL-38999												
USB Orientation*	H = Horizontal V = Vertical												
Shrink Boot	T = Shrink Boot Part No. 770-028 (Omit for None)												

*For panel cut-out dimensions, electrical specifications and RJ45 Orientation Options see page E-11 and E-12

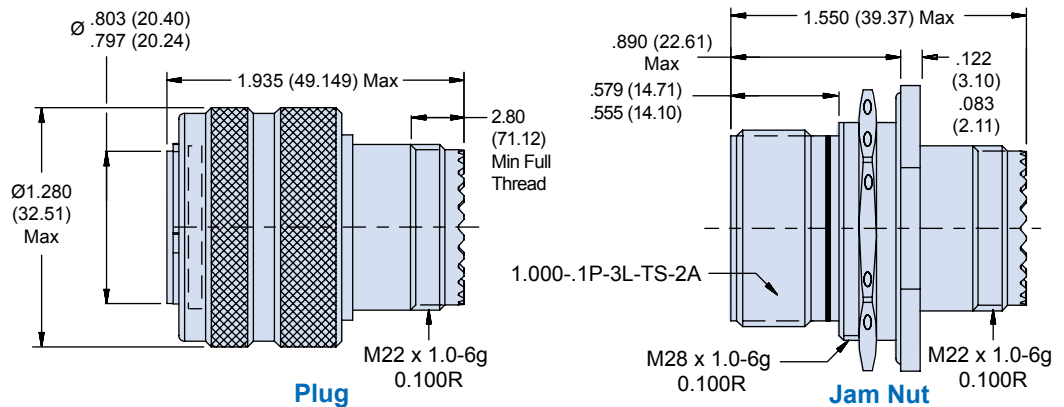
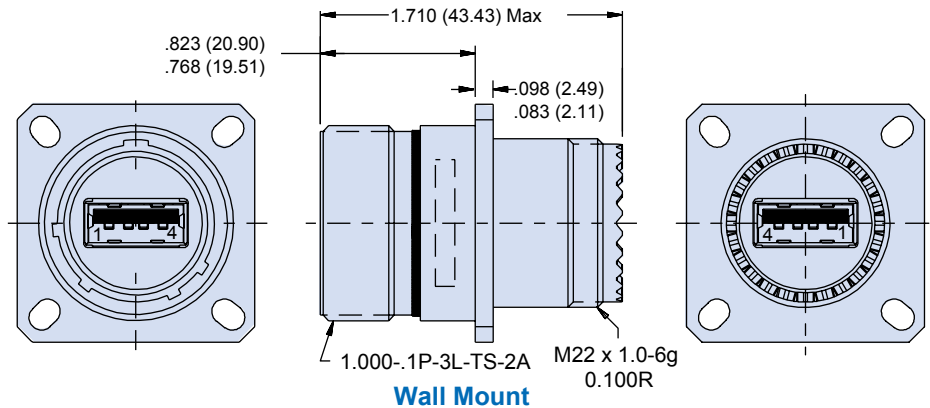

NOTES

1. All external dimensions, features, etc. compliant with D38999/20, /24 & /26.
2. Consult factory for additional information
3. Size 17 shells also available. Consult factory, refer to P/N 233-360.
4. Consult factory for additional information