

Connectors for Astronaut Operations

In the frame of Space Station Alpha program, SOURIAU has developed and qualified a series of Astronaut operable high reliability rectangular connectors which are suitable for both IVA & EVA activities. This hardware is used on the COF (Columbus Orbital Facility) module which is part of the European contribution to the Space Station. These connectors feature :

- Low Insertion Force contacts
- High density of contacts (72 # 22)
- Scoop proof design
- High durability (5000 mating/demating operations)
- High EMI shielding efficiency
- Associated dismountable EMI backshells
- Easy inspection, maintenance or repair after wiring.



Characteristics

Materials and finishes

Components	Material	Finish
Shells & backshells	Aluminium alloy	Nickel plating : electroless & flashing
Inserts - Insulator - Wire guide	Duroplastic Silicone	- -
Contacts	See L.I.F. contacts	See L.I.F. contacts
Contact retaining clip	Copper alloy	-
Locking device - Mechanical parts - Springs	Aluminium alloy Stainless steel or Beryllium copper	Electroless Electrolytic Nickel plated -

Maximum ratings

N°	Characteristics	Symbol	Maximum ratings		Unit
			min	Max.	
1	Working voltage (sea level)	U_r	—	200	Vrms
2	Rating current	I_r	—	5	A
3	Operating temperature range Mating/Demating in mated status	T_{op}	-55 +15	+150 +40	°C °C
4	Storage temperature range	T_{stg}	-65	+150	°C
5	Soldering temperature	T_{sol}	—	+260	°C
6	Connector life	—	—	> 500	cycles (1)

(1) 1 cycle = 1 mating/demating over 10 years

Electrical characteristics

N°	Characteristics	Symbol	Test method	Test condition	Limits		Unit
					min	Max.	
1	Insulation resistance	R_i	ESA/SCC 3401 para. 9.1.1.1	para. 9.1.1.1	10 000	—	M Ω
2	Voltage proof - Leakage current	I_L	ESA/SCC 3401 para. 9.1.1.2	800 Vrms	—	2	mA
3	Mated shell conductivity (1)	R	ESA/SCC 3401 para. 9.1.1.4	para. 9.1.1.4	—	7	m Ω
4	Contact resistance	R_c	ESA/SCC 3401 para. 9.1.1.3	para. 9.1.1.3	—	6	m Ω

(1) From grounding screw of the backshell to the receptacle flange.
(These measurements have been performed at : $T_{amb} = + 22 \pm 3^\circ\text{C}$).

Connectors for Astronaut Operations



Part Number / Ordering information

Family identification code	8976	R	M	072	C	S	xx
Type of component	R : receptacle P : plug						
Size of connector	L : large M : medium S : small						
Layout							
Contacts	C : short spills -- : crimp contacts						
Contact type	P : pin S : socket						
Coding system (see examples below)	NØ = no coding system Different types of coding, according to the sizes of connectors, are available on request						

Coding system (for medium size)

Polarization code	Main coding position		Secondary coding position							
	A	B	1	2	3	4	5	6	7	8
A1	x		x							
A2	x			x						
A3	x				x					
A4	x					x				
A5	x						x			
A6	x							x		
A7	x								x	
A8	x									x

Polarization code	Main coding position		Secondary coding position							
	A	B	1	2	3	4	5	6	7	8
B1		x	x							
B2		x		x						
B3		x			x					
B4		x				x				
B5		x					x			
B6		x						x		
B7		x							x	
B8		x								x

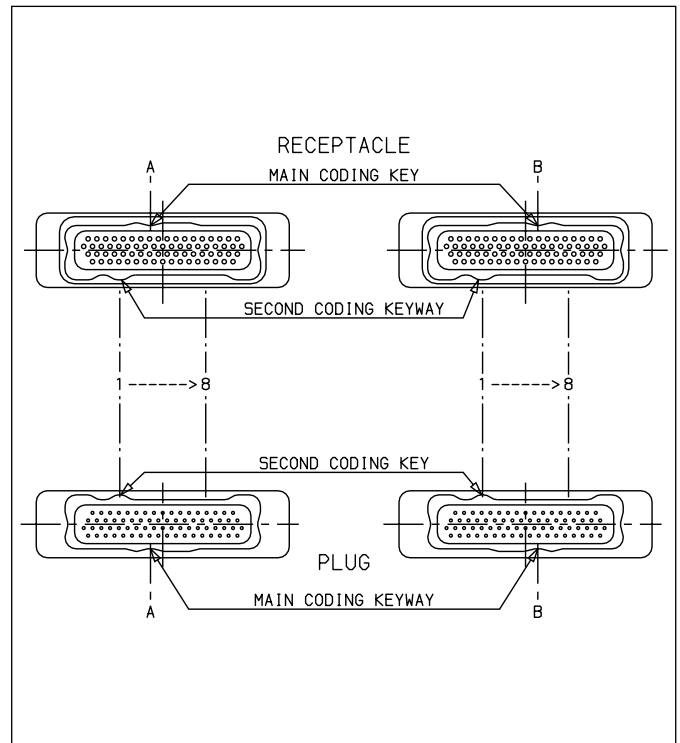



Connectors for Astronaut Operations

Range of component / Type of variants

Component Type	Max Mass (g)		Max Mating force (N)		Max Demating force (N)	
	Medium	Large	Medium	Large	Medium	Large
Plug for crimp male contacts	60	90	50	100	45	90
Receptacle for crimp female contacts (*)	60	90	50	100	45	90

(*) Available with spill female contacts

Component Type	Max Mass (g)	
	Medium	Large
Backshell, straight outlet	45	64
Backshell, 45° outlet	49	70

Crimping, insertion & removal tools

Contact size	Contact part number	Crimping tools	Positioner	Insertion and removal plastic tools
# 22	Pin Socket	M22520/2-01	8976-700 M22520/2-07	M81969/14-01
# 20	Pin Socket			M81969/14-10
# 16	Pin Socket	M22520/1-01	M22520/1-04	M81969/14-03
# 12	Pin Socket			M81969/14-04
# 12 coax	Inner pin Inner socket Crimping sleeve	M22520/5-01	8976-720 8976-710 8976-730	

Dimensions (in mm)

Plug (for medium size)

A	B	C	D	E
68 ⁰ _{-0,51}	18 ⁰ _{-0,11}	52,5 ⁰ _{-0,11}	14,5 ⁰ _{-0,11}	17 ⁰ _{-0,1}
F	G	H	J	L
27,35 ⁰ _{-0,11}	52 ⁰ _{-0,11}	16 ⁰ _{-0,11}	2,16 ^{+0,05} ₊₀	55,5 _{maxi}

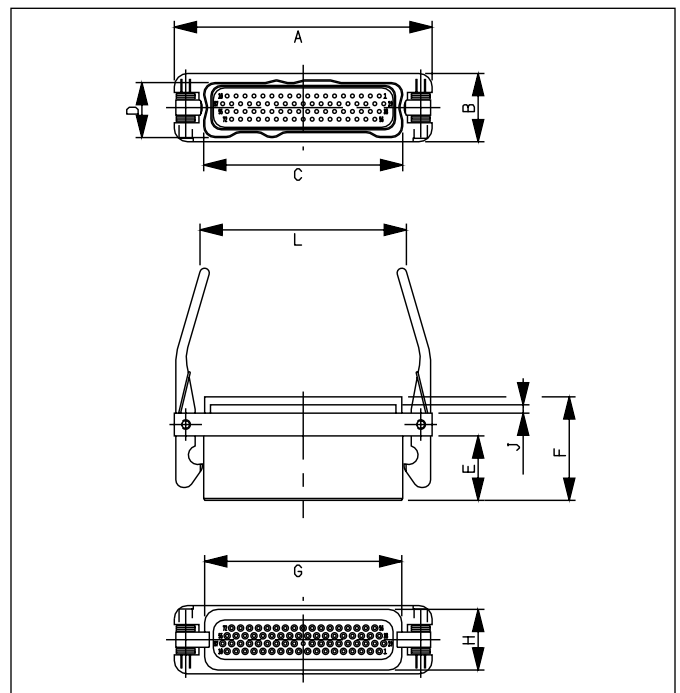

Connectors for Astronaut Operations



Receptacle for spill contacts (for medium size)

A	B	C	D	E
$67,99^{+0,5}_{+0}$	$20^{-0}_{-0,11}$	$55,5^{-0}_{-0,11}$	$18^{-0}_{-0,11}$	$52^{-0}_{-0,11}$
F	G	H	J	K
$16^{-0}_{-0,11}$	$20,5^{0}_{-0,11}$	$3^{-0}_{-0,11}$	$28^{-0}_{-0,11}$	$8,2^{+0,9}_{+0}$
L	Ø M	N	Ø R	
$4^{-0}_{-0,11}$	$0,49^{+0,02}_{-0,05}$	62	$3,1^{+0,2}$	

For crimp contacts :
same dimensions without K, L & Ø M.

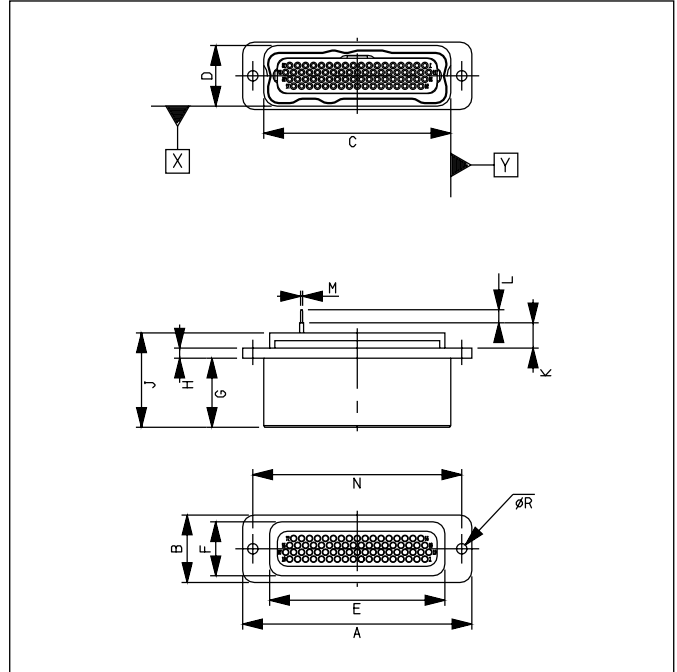

Backshell (for medium size)

A	B*	G	K
$55^{-0}_{-0,11}$	$18^{-0}_{-0,11}$	$52^{-0}_{-0,21}$	$48,04^{+0,5}$
Fa	Fb	J	
$56,9^{+0,75}_{-0,75}$	$74,5^{+1}_{-1}$	$227 \text{ mm}^{+10}_{+0}$	

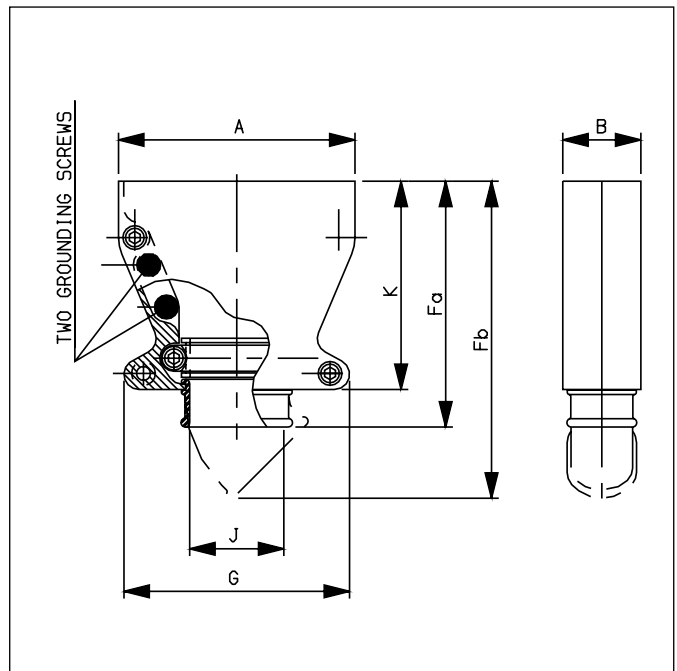

Layouts (from 8976)

See page 87



Connectors for Astronaut Operations

External dimensions for medium connector front & Rear mounting

Panel cut-out for receptacle

E	F	Ø G	r1	J	H	M	K
31	62	$3,20^{+0}_{+0,10}$	$3^{0}_{-0,50}$	$52,30^{+0,20}_{+0}$	$16,30^{+0,20}_{+0}$	$55,80^{+0,20}_{+0}$	$18,30^{+0,20}_{+0}$
		$= 0,10 / x \approx 0,10 / x / y$	Front mounting		Rear mounting		

Receptacle front mounting

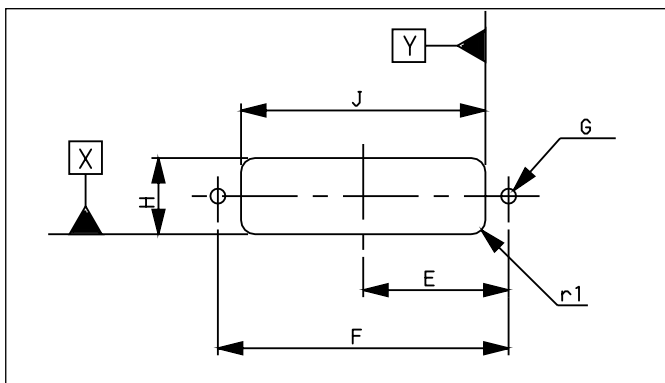

Receptacle rear mounting

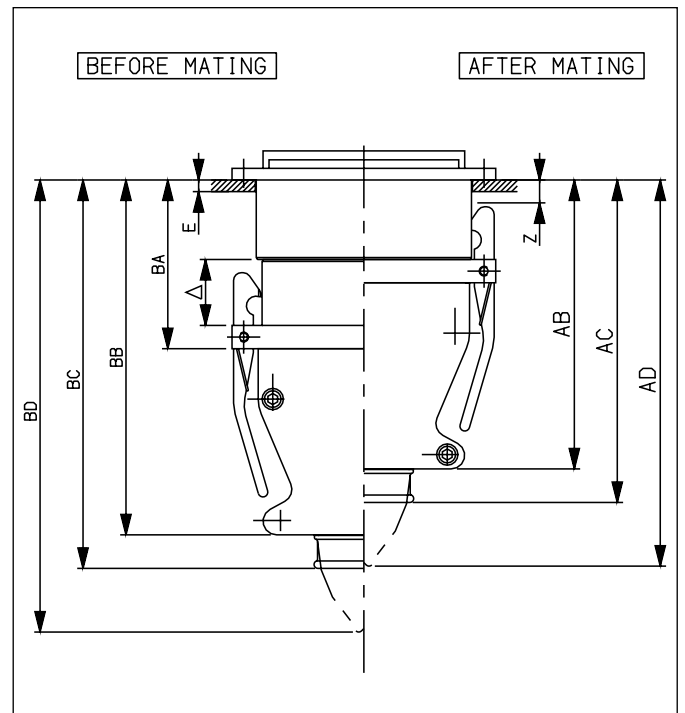
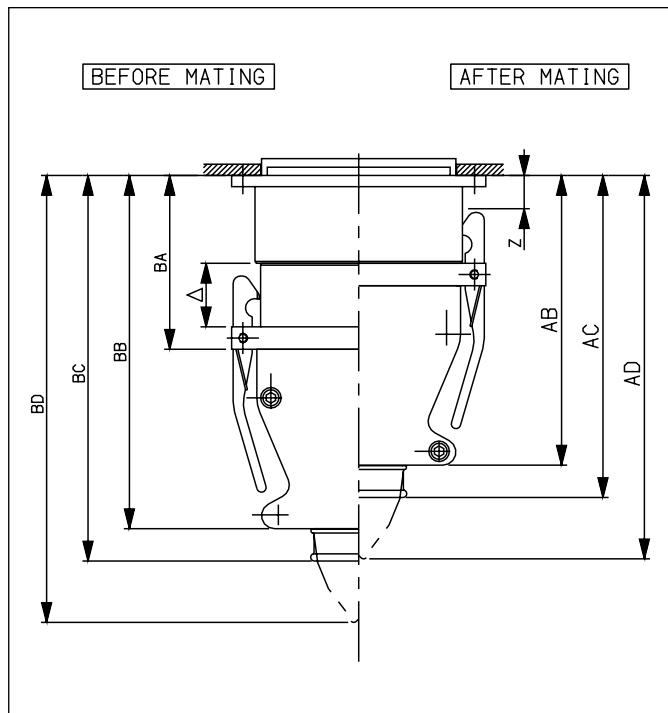
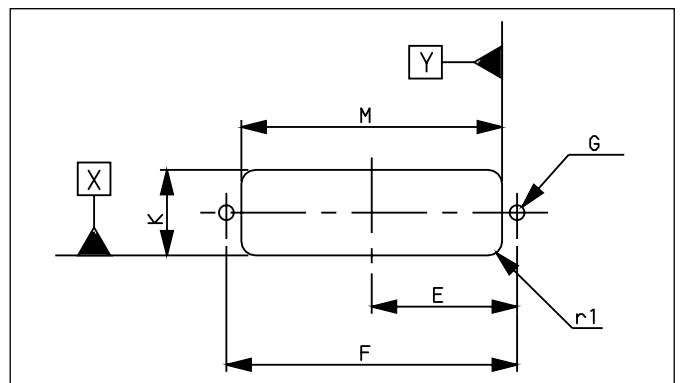

		Straight outlet		45° outlet
BA	BB	BC	AC	BD
$40,5^{0}_{-0,31}$	$94,80^{+0,70}_{-0,70}$	$103,4^{+1,10}_{-1,10}$	$86,45^{+1,15}_{-1,15}$	$121^{+1,50}_{-1,50}$
AD	AB	D	Z Max	
$104^{+1,50}_{-1,50}$	$77,85^{+0,75}_{-0,75}$	$17^{0}_{-0,10}$	6,5	

		Straight outlet		45° outlet
BA	BB	BC	AC	BD
$37,5^{0}_{-0,20}$	$91,85^{+0,65}_{-0,65}$	$100,45^{+1,05}_{-1,05}$	$83,50^{+1,10}_{-1,10}$	$118^{+1,50}_{-1,50}$
AD	AB	D	Z Max	
$101^{+1,50}_{-1,50}$	$74,90^{+0,70}_{-0,70}$	$17^{0}_{-0,10}$	6,5	