

VFJA1491P

Jitter Attenuator / Clock Generator

Features

- Frequency Range 10MHz to 200 MHz
- 14mm x 9mm Surface Mount Package
- 3.3V LVPECL Output
- Low Jitter/Phase Noise
- Tape and Reel Packaging

Applications

- Telecom Switching
- Wireless Communication
- Timing over Packet

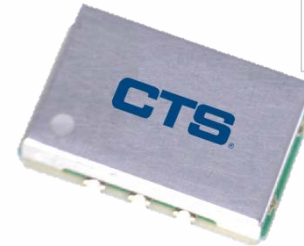

Dimensions: 14.12 x 9.27 x 3 mm

Description

The VFJA1491P is a Jitter Attenuator which accepts an input reference clock up to 200 MHz and provides an output frequency up to 200 MHz. The output frequency is determined by a VCXO designed for low phase noise. The VFJA1491P is available in a 14 mm x 9 mm surface mount package.

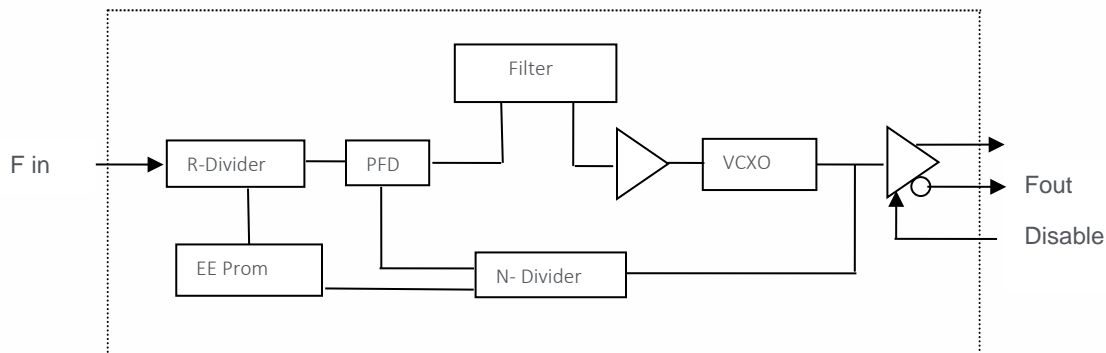

Block Diagram



Electrical Specifications

Parameter	Symbol	Conditions & Remarks	Min	Typical	Max	Unit
Input Frequency	F_{in}	Slew Rate 1.0V/ns	10	-	200	MHz
Input Level		DC coupled internally	0.4		3.3	Vp-p
Output Frequency	F_{out}		10		200	MHz
Output Voltage Levels	V_{OH} V_{OL}	50 Ω to V_{CC} -2V or Thevenin Equivalent	V_{CC} -.95 V_{CC} -1.65		V_{CC} -.85 V_{CC} -1.53	V
Duty Cycle		@ 50% V_{out} (p-p)	45		55	%
Rise / Fall Times	T_r/T_f	20% to 80%			0.5	ns
Lock Range	APR		± 20			ppm
Modulation BW	MBW		10			Hz
Operating Temperature Range	T_a		-40		+85	$^{\circ}C$
Jitter		12kHz to 20 MHz		65	120	fs
SSB Output Phase Noise @ 156.25 MHz	ϕ_n	100 Hz offset		-101		dBc/Hz
		1K Hz offset		-128		
		10K Hz offset		-146		
		100K Hz offset		-156		
		1M Hz offset		-160		
Start-up Time				2	3	s
Supply Voltage			+3.15	3.30	+3.45	V
Input Current				85	100	mA
Enable / Disable		Logic "0" (< 0.5V or floating) Output Enabled Logic "1" (> 2.2V) Output Disabled				LVC MOS
Enable / Disable Time					100	ns

Absolute Maximum Ratings

Parameter	Symbol	Conditions & Remarks	Min	Typical	Max	Unit
Supply Breakdown Voltage	V_{CC}		-0.5		+4.0	V
Storage Temperature	T_s		-50		+95	$^{\circ}C$

Mechanical and Environmental

Mechanical Shock	Per MIL-STD-202, Method 213, Condition E
Thermal Shock	Per MIL-STD-883, Method 1011, Condition A
Vibration	Per MIL-STD-883, Method 2007, Condition A
Soldering Conditions	260°C for 10s max
Hermetic Seal	Leak rate less than 5×10^{-8} atm.cc/s of helium (crystal only)

Phase Noise Performance @ Fout = 156.25 MHz

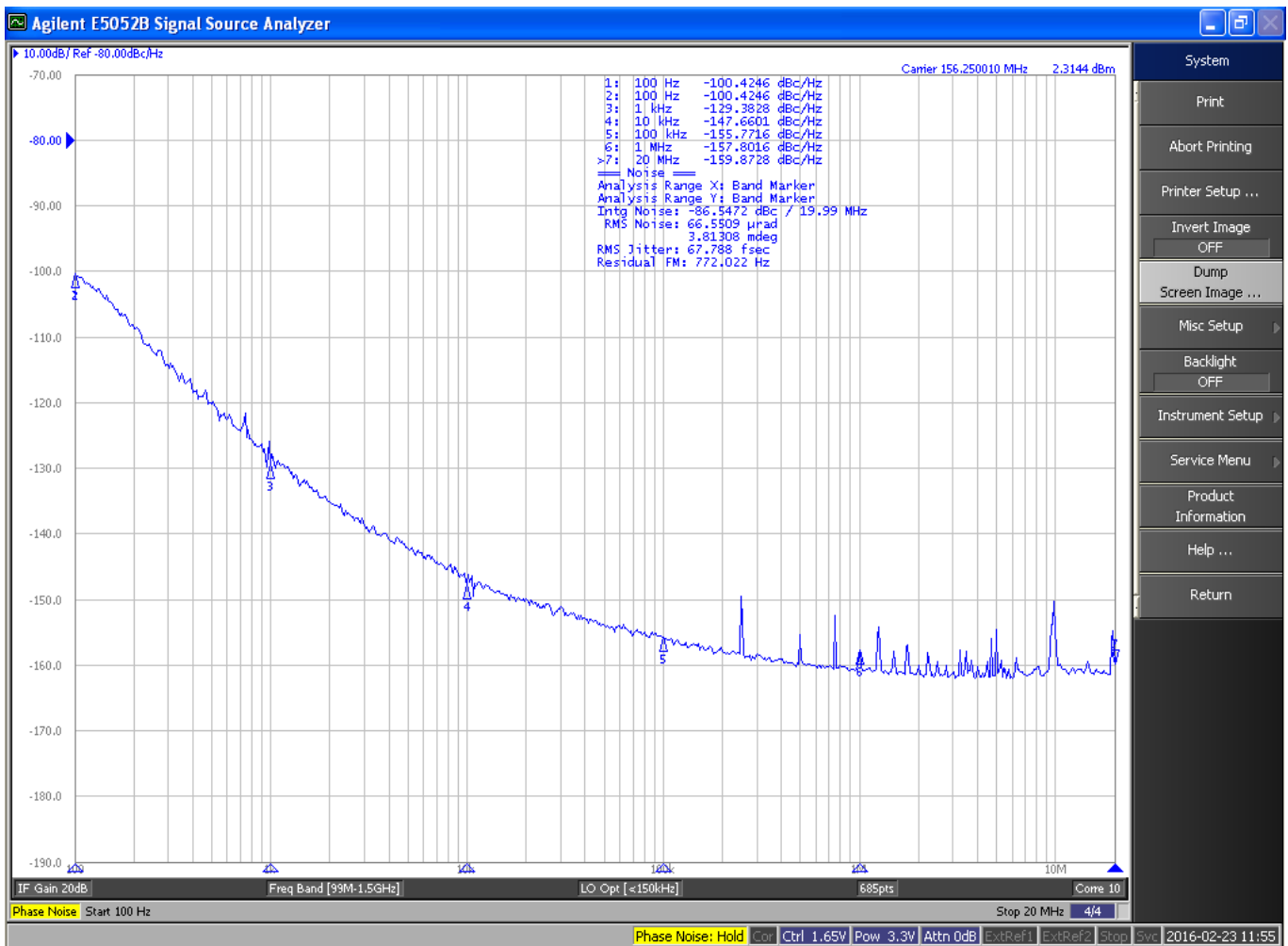

Standard Frequencies

Part Number	Output Frequency	Input Frequency	Loop BW
VFJA1491P-156.25M-156.25M	156.25 MHz	156.25 MHz	15 Hz
VFJA1491P-156.25M-25.0M	156.25 MHz	25.00 MHz	15 Hz
VFJA1491P-125M-25.0M	125.00MHz	25.00 MHz	15 Hz
VFJA1491P-25.0M-25.0M	25.00 Mhz	25.00 MHz	35 Hz

Consult factory for more frequency and bandwidth options.

How to Order

Model Number	Output Frequency	Input Frequency
VFJA1491P	XXX.XXX M	XXX.XXX M

Marking

<p>VFJA1491P xxx.xxxMHz (F_{OUT}) xxx.xxxMHz (F_{IN}) XXYY (Date code)</p> 
--

Connection Diagram

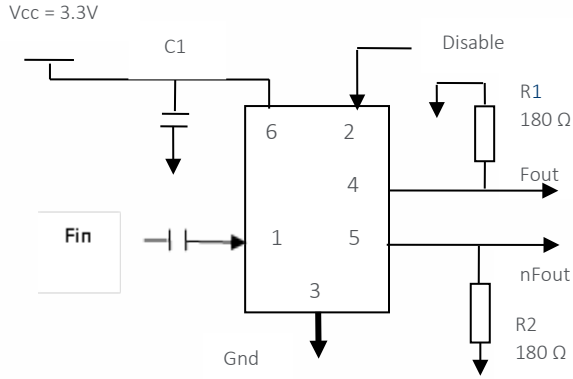

Pin Assignments

Pin #	Connection
1	Fin
2	Disable
3	Case, Gnd
4	Fout
5	NFout
6	Vcc

Mechanical Specifications

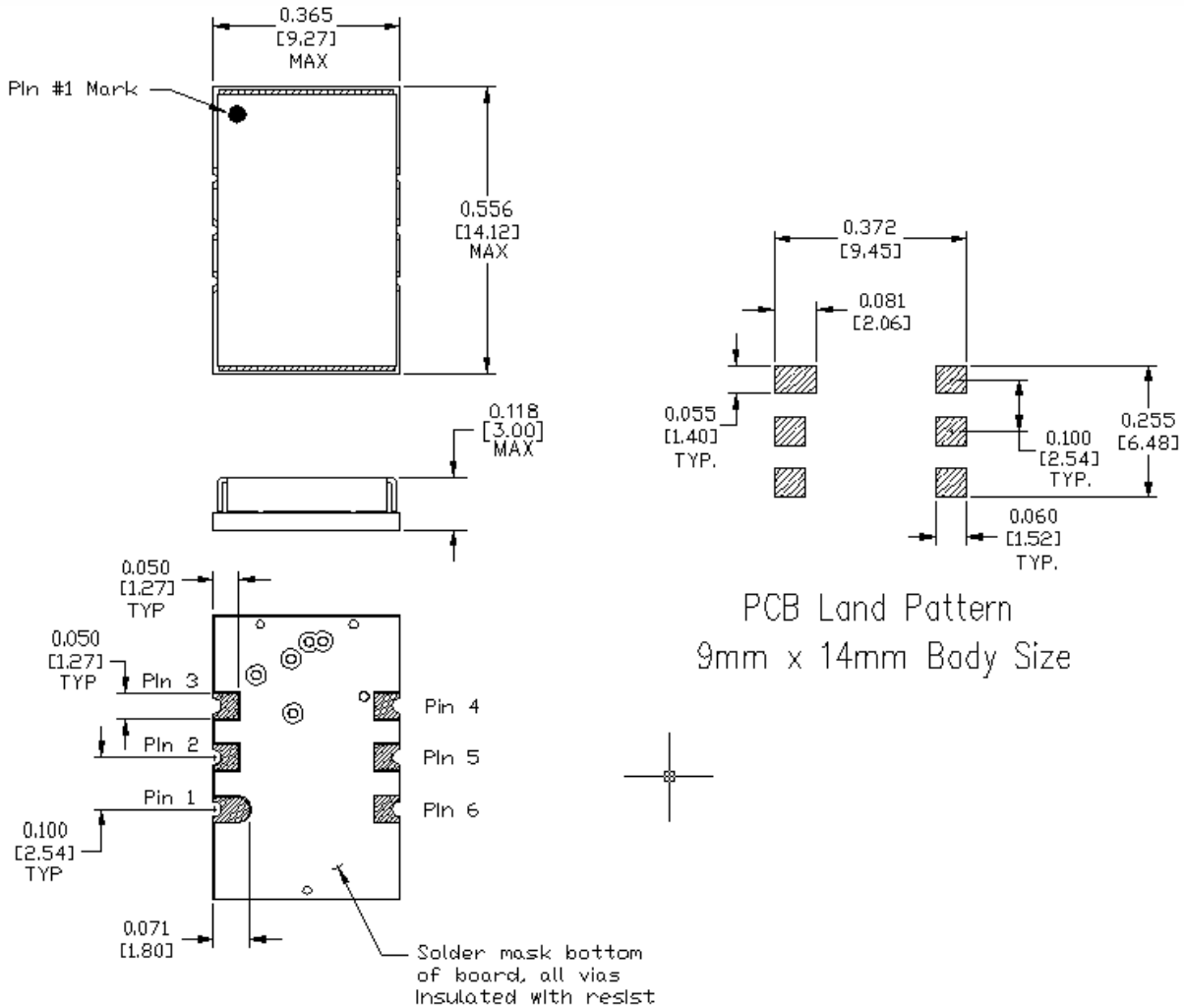

PCB Land Pattern
9mm x 14mm Body Size

This product is specified for use only in standard commercial applications. Supplier disclaims all express and implied warranties and liability in connection with any use of this product in any non-commercial applications or in any application that may expose the product to conditions that are outside of the tolerances provided in its specification.