

256 K x 16-Bit EDO-Dynamic RAM

HYB514265BJ-400/40/-45/-50
HYB314265BJ(L)-45/-50

Preliminary Information

- 262 144 words by 16-bit organization
- 0 to 70 °C operating temperature
- EDO - Hyper Page Mode
- Performance:

	-400	-40	-45	-50	
trc	69	69	79	89	ns
trac	40	40	45	50	ns
tcac	10	10	12	13	ns
taa	20	20	22	25	ns
thpc	12,5	15	18	20	ns
fhpc	80	66	55	50	MHz

- Low Power dissipation
 - Active(max.):
150mA / 150mA / 130mA / 120 mA
 - Standby : TTL Inputs (max.) 2.0 mA
 - Standby: CMOS Inputs (max.) 1.0 mA
 - Standby (L-version) 200 µA

- Power Supply:

HYB514265BJ-400	+5 V	±10%
HYB514265BJ-40	+5 V	±10%
HYB514265BJ-45	+5 V	±10%
HYB514265BJ-50	+5 V	±10%
HYB314265BJ(L)-45	+3.3V	±0.3 V
HYB314265BJ(L)-50	+3.3V	±0.3 V

- Read, write, read-modify-write, $\overline{\text{CAS}}$ -before $\overline{\text{RAS}}$ refresh, $\overline{\text{RAS}}$ only refresh, hidden refresh mode
- Low Power Version (L) with Self Refresh and 250 µA self refresh current
- 2 $\overline{\text{CAS}}$ / 1 $\overline{\text{WE}}$ control
- All inputs and outputs TTL-compatible
- 512 refresh cycles / 16 ms
512 refresh cycles / 128 ms (L-version)
- Plastic Packages: P-SOJ-40-1 400 mil width

The HYB 5(3)14265BJ(L) is the new generation dynamic RAM organized as 262 144 words by 16-bit. The HYB 5(3)14265BJ(L) utilizes the SIEMENS 16M-CMOS submicron silicon gate process as well as advanced circuit techniques to provide wide operation margins, both internally and for the system user. Multiplexed address inputs permit the HYB 5(3)14265BJ(L) to be packed in a standard plastic 400mil wide P-SOJ-40-1 package. This package size provides high system bit densities and is compatible with commonly used automatic testing and insertion equipment.

The HYB314265BJL parts have a very low power "sleep mode" supported by Self Refresh.

Ordering Information

Type	Ordering Code	Package	Description
5 V versions:			
HYB 514265BJ-400		P-SOJ-40-1	5V 40 ns 256 K x 16 EDO-DRAM
HYB 514265BJ-40		P-SOJ-40-1	5V 40 ns 256 K x 16 EDO-DRAM
HYB 514265BJ-45	Q67100-3001	P-SOJ-40-1	5V 45 ns 256 K x 16 EDO-DRAM
HYB 514265BJ-50	Q67100-3003	P-SOJ-40-1	5V 50 ns 256 K x 16 EDO-DRAM
3.3V versions:			
HYB 314265BJ-45	Q67100-3009	P-SOJ-40-1	3.3V 45 ns 256 K x 16 EDO- DRAM
HYB 314265BJ-50	Q67100-3013	P-SOJ-40-1	3.3V 50 ns 256 K x 16 EDO- DRAM
HYB 314265BJL-45	on request	P-SOJ-40-1	3.3V Low Power 45 ns 256 K x 16 EDO- DRAM
HYB 314265BJL-50	on request	P-SOJ-40-1	3.3V Low Power 50 ns 256 K x 16 EDO-DRAM

Truth Table

RAS	LCAS	UCAS	WE	OE	I/O1-I/O8	I/O9-I/O16	Operation
H	H	H	H	H	High-Z	High-Z	Standby
L	H	H	H	H	High-Z	High-Z	Refresh
L	L	H	H	L	Dout	High-Z	Lower byte read
L	H	L	H	L	High-Z	Dout	Upper byte read
L	L	L	H	L	Dout	Dout	Word read
L	L	H	L	H	Din	Don't care	Lower byte write
L	H	L	L	H	Don't care	Din	Upper byte write
L	L	L	L	H	Din	Din	Word write
L	L	L	H	H	High-Z	High-Z	

Pin Names

A0-A8	Address Inputs
RAS	Row Address Strobe
UCAS, LCAS	Column Address Strobe
WE	Read/Write Input
OE	Output Enable
I/O1 – I/O16	Data Input/Output
V _{CC}	Power Supply: + 5 V for HYB514265, + 3.3V for HYB314265
V _{SS}	Ground (0 V)
N.C.	No Connection

Pin Configuration

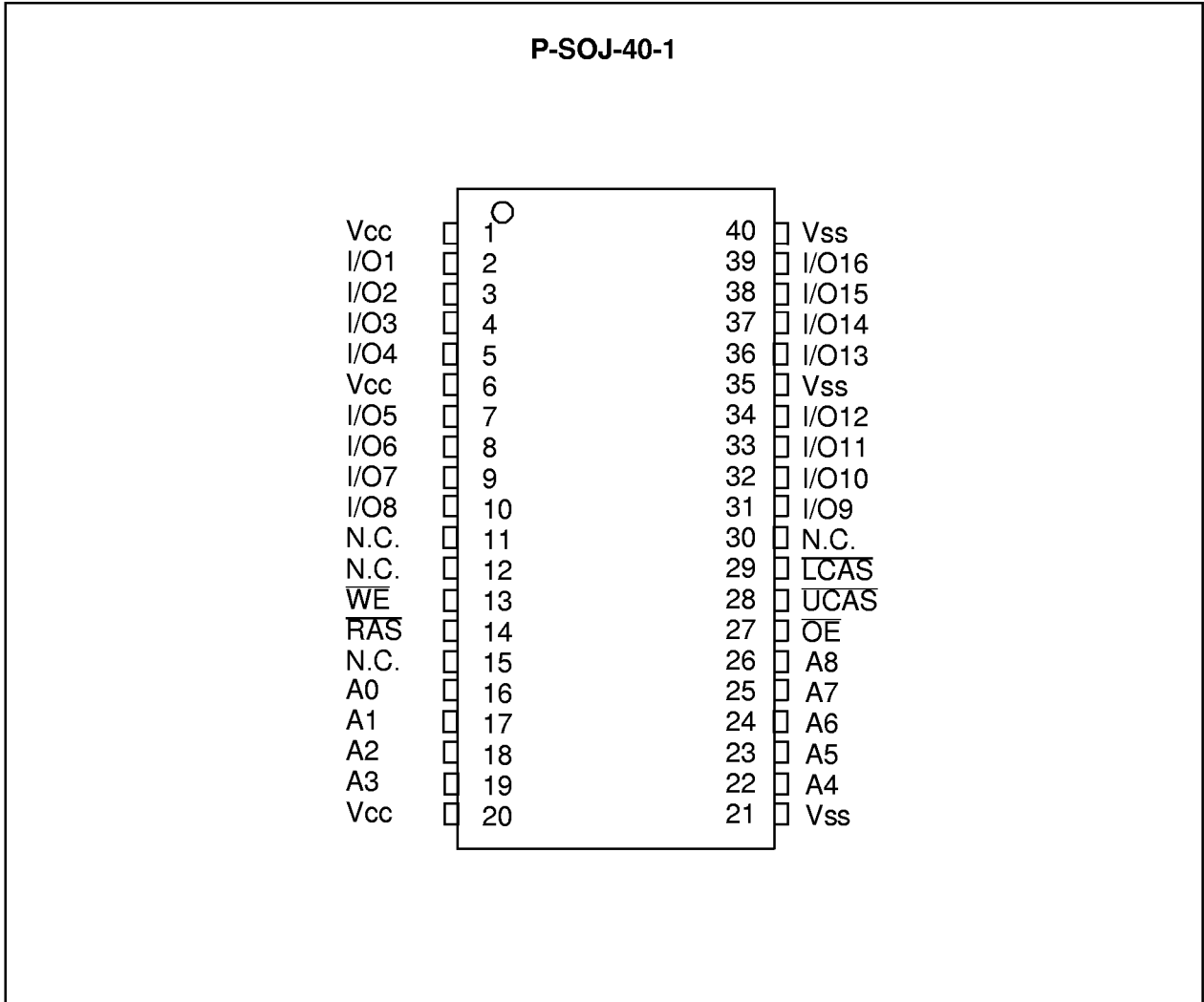

Block Diagram

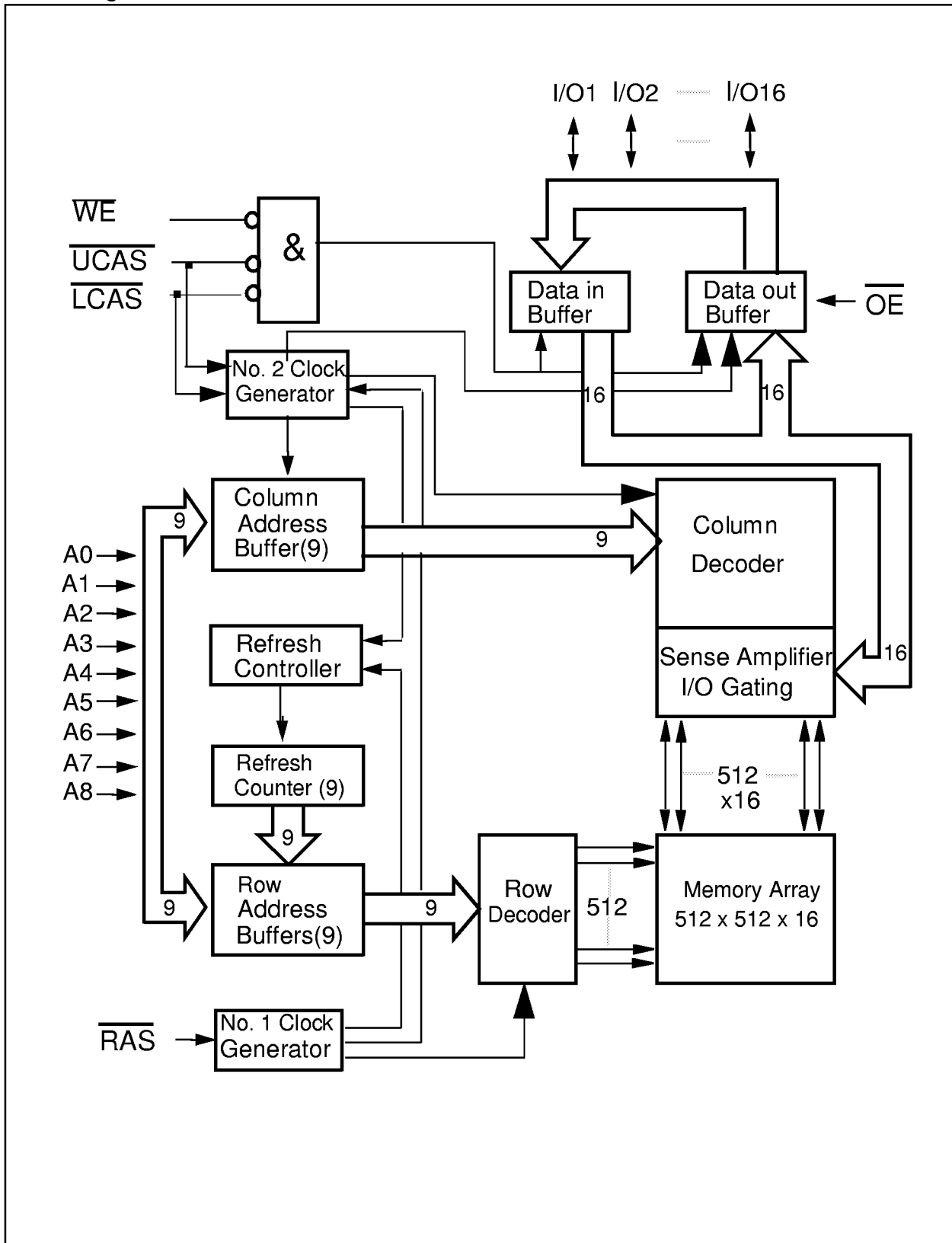

Absolute Maximum Ratings

Operating temperature range	0 to + 70 °C
Storage temperature range.....	- 55 to + 150 °C
Input/output voltage for HYB514265.....	-0.5 to min. (V _{CC} + 0.5, 7.0) V
Power supply voltage for HYB514265	- 1 to + 7 V
Input/output voltage for HYB314265.....	-0.5 to min. (V _{CC} + 0.5, 4.6) V
Power supply voltage for HYB314265	- 0.5 to + 4.6 V
Data out current (short circuit)	50 mA

Note: Stresses above those listed under “Absolute Maximum Ratings” may cause permanent damage of the device. Exposure to absolute maximum rating conditions for extended periods may affect device reliability.

DC Characteristics for HYB514265

T_A = 0 to 70 °C; V_{SS} = 0 V; V_{CC} = 5 V ± 10 % , t_T = 2 ns

Parameter	Symbol	Limit Values		Unit	Notes
		min.	max.		
Input high voltage	V _{IH}	2.4	V _{CC} +0.5	V	1
Input low voltage	V _{IL}	- 0.5	0.8	V	1
Output high voltage (I _{OUT} = - 5.0 mA)	V _{OH}	2.4	-	V	1
Output low voltage (I _{OUT} = 4.2 mA)	V _{OL}	-	0.4	V	1
Input leakage current, any input (0 V < V _{IN} < 7 V, all other inputs = 0 V)	I _{I(L)}	- 10	10	μA	1
Output leakage current (DO is disabled, 0 V < V _{OUT} < V _{CC})	I _{O(L)}	- 10	10	μA	1
Average V _{CC} supply current: - -400 version -40 version -45 version -50 version	I _{CC1}		150 150 130 120	mA	2, 3, 4
Standby V _{CC} supply current (RAS = LCAS = UCAS = WE = V _{IH})	I _{CC2}		2	mA	-
Average V _{CC} supply current during RAS-only refresh cycles: -400 version -40 version -45 version -50 version	I _{CC3}		150 150 130 120	mA	2, 4

Parameter	Symbol	Limit Values		Unit	Notes
		min.	max.		
Average V_{CC} supply current during hyper page mode (EDO) operation: -400 version -40 version -45 version -50 version	I_{CC4}		110 90 75 65	mA	2, 3, 4
Standby V_{CC} supply current ($\overline{RAS} = \overline{LCAS} = \overline{UCAS} = \overline{WE} = V_{CC} - 0.2 V$)	I_{CC5}		1	mA	1
Standby V_{CC} supply current (L-version only) ($\overline{RAS} = \overline{LCAS} = \overline{UCAS} = \overline{WE} = V_{CC} - 0.2 V$)	I_{CC5}		200	μA	1
Average V_{CC} supply current during \overline{CAS} -before- \overline{RAS} refresh mode: -400 version -40 version -45 version -50 version	I_{CC6}		150 150 130 120	mA	2, 4

DC Characteristics for 314265

$T_A = 0$ to 70 °C; $V_{SS} = 0 V$; $V_{CC} = 3.3 V \pm 0.3 V$, $t_T = 2 ns$

Parameter	Symbol	Limit Values		Unit	Test Condition
		min.	max.		
Input high voltage	V_{IH}	2.0	$V_{CC} + 0.5$	V	1
Input low voltage	V_{IL}	- 0.5	0.8	V	1
TTL Output high voltage ($I_{OUT} = - 2.0 mA$)	V_{OH}	2.4	-	V	1
TTL Output low voltage ($I_{OUT} = 2 mA$)	V_{OL}	-	0.4	V	1
CMOS Output high voltage ($I_{OUT} = - 100 \mu A$)	V_{OH}	2.4	-	V	1
CMOS Output low voltage ($I_{OUT} = 100 \mu A$)	V_{OL}	-	0.4	V	1
Input leakage current, any input ($0 V < V_{IN} < V_{CC} + 0.3V$, all other inputs = $0 V$)	$I_{I(L)}$	- 10	10	μA	1
Output leakage current (DO is disabled, $0 V < V_{OUT} < V_{CC} + 0.3V$)	$I_{O(L)}$	- 10	10	μA	1
Average V_{CC} supply current: -45 version -50 version	I_{CC1}		130 120	mA	2, 3, 4
Standby V_{CC} supply current ($\overline{RAS} = \overline{LCAS} = \overline{UCAS} = \overline{WE} = V_{IH}$)	I_{CC2}		2	mA	-

Parameter	Symbol	Limit Values		Unit	Test Condition
		min.	max.		
Average V_{CC} supply current during \overline{RAS} -only refresh cycles: -45 version -50 version	I_{CC3}		130 120	mA	2, 4
Average V_{CC} supply current during hyper page mode (EDO) operation: -45 version -50 version	I_{CC4}		75 65	mA	2, 3, 4
Standby V_{CC} supply current ($\overline{RAS} = \overline{LCAS} = \overline{UCAS} = \overline{WE} = V_{CC} - 0.2$ V)	I_{CC5}		1	mA	1
Standby V_{CC} supply current (L-version only) ($\overline{RAS} = \overline{LCAS} = \overline{UCAS} = \overline{WE} = V_{CC} - 0.2$ V)	I_{CC5}		200	μ A	1
Average V_{CC} supply current during \overline{CAS} -before- \overline{RAS} refresh mode: -45 version -50 version	I_{CC6}		130 120	mA	2, 4
Self Refresh Current (L-version only) CBR cycle with $\overline{RAS} > t_{rasss}(\text{min})$, CAS held low; $\overline{WE} = V_{CC} - 0.2$ V, Addresses and Din = $V_{CC} - 0.2$ V or 0.2V	I_{CC7}		250	μ A	

Capacitance

$T_A = 0$ to 70 °C; $f = 1$ MHz

Parameter	Symbol	Limit Values		Unit
		min.	max.	
Input capacitance (A0 to A8)	C_{I1}	–	5	pF
Input capacitance (\overline{RAS} , \overline{UCAS} , \overline{LCAS} , \overline{WE} , \overline{OE})	C_{I2}	–	7	pF
Output capacitance (I/O1 to I/O16)	C_{I0}	–	7	pF

AC Characteristics ^{5) 6)}

$T_A = 0$ to 70 °C, $t_T = 2$ ns

Parameter	Symbol	Limit Values				Unit	Note
		-400		-40			
		min.	max.	min.	max.		

common parameters

Random read or write cycle time	t_{RC}	69	–	69	–	ns	
\overline{RAS} precharge time	t_{RP}	25	–	25	–	ns	
\overline{RAS} pulse width	t_{RAS}	40	10k	40	10k	ns	
\overline{CAS} pulse width	t_{CAS}	4.5	10k	6	10k	ns	
\overline{CAS} precharge time	t_{CP}	4	–	5	–	ns	
Row address setup time	t_{ASR}	0	–	0	–	ns	
Row address hold time	t_{RAH}	5	–	5	–	ns	
Column address setup time	t_{ASC}	0	–	0	–	ns	
Column address hold time	t_{CAH}	5	–	5	–	ns	
\overline{RAS} to \overline{CAS} delaytime	t_{RCD}	9	30	9	30	ns	
\overline{RAS} to column address delay time	t_{RAD}	7	20	7	20	ns	
\overline{RAS} hold time	t_{RSH}	6	–	6	–	ns	
\overline{CAS} hold time	t_{CSH}	32	–	32	–	ns	
\overline{CAS} to \overline{RAS} precharge time	t_{CRP}	5	–	5	–	ns	
Transition time(rise and fall)	t_T	1	50	1	50	ns	7
Refresh period	t_{REF}	16	–	16	–	ms	

Read Cycle

Access time from \overline{RAS}	t_{RAC}	–	40	–	40	ns	8, 9
Access time from \overline{CAS}	t_{CAC}	–	10	–	10	ns	8, 9
Access time from column address	t_{AA}	–	17	–	20	ns	8,10
\overline{OE} access time	t_{OEA}	–	10	–	10	ns	
Column address to \overline{RAS} lead time	t_{RAL}	20	–	20	–	ns	
Read command setup time	t_{RCS}	0	–	0	–	ns	
Read command hold time	t_{RCH}	0	–	0	–	ns	11
Read command hold time ref. to \overline{RAS}	t_{RRH}	0	–	0	–	ns	11
\overline{CAS} to output inlow-Z	t_{CLZ}	0	–	0	–	ns	8
Output buffer turn-off delay from \overline{CAS}	t_{OFF}	0	–	0	10	ns	12
Output buffer turn-off delay from \overline{OE}	t_{OEZ}	0	10	0	10	ns	12

Parameter	Symbol	Limit Values				Unit	Note
		-400		-40			
		min.	max.	min.	max.		
Data to $\overline{\text{OE}}$ low delay	t_{DZO}	0	–	0		ns	13
$\overline{\text{CAS}}$ high to data delay	t_{CDD}	8	–	8	–	ns	14
$\overline{\text{OE}}$ high to data delay	t_{ODD}	8	–	8	–	ns	14
Data to $\overline{\text{CAS}}$ low delay	t_{DZC}	0	–	0	–	ns	13

Write Cycle

Write command hold time	t_{WCH}	5	–	5	–	ns	
Write command pulse width	t_{WP}	5	–	5	–	ns	
Write command setup time	t_{WCS}	0	–	0	–	ns	15
Write command to $\overline{\text{RAS}}$ lead time	t_{RWL}	10	–	10	–	ns	
Write command to $\overline{\text{CAS}}$ lead time	t_{CWL}	10	–	10	–	ns	
Data setup time	t_{DS}	0	–	0	–	ns	16
Data hold time	t_{DH}	5	–	5	–	ns	16
Data to $\overline{\text{CAS}}$ low delay	t_{DZC}	0	–	0	–	ns	13

Read-modify-Write Cycle

Read-write cycle time	t_{RWC}	93	–	93	–	ns	
$\overline{\text{RAS}}$ to $\overline{\text{WE}}$ delay time	t_{RWD}	52	–	52	–	ns	15
$\overline{\text{CAS}}$ to $\overline{\text{WE}}$ delay time	t_{CWD}	22	–	22	–	ns	15
Column address to $\overline{\text{WE}}$ delay time	t_{AWD}	32	–	32	–	ns	15
$\overline{\text{OE}}$ command hold time	t_{OEH}	5	–	5	–	ns	

Hyper Page Mode (EDO) Cycle

Hyper page mode cycle time	t_{HPC}	12.5	–	15	–	ns	
Access time from $\overline{\text{CAS}}$ precharge	t_{CPA}	–	17	–	21	ns	7
Output data hold time	t_{COH}	3	–	3	–	ns	
$\overline{\text{RAS}}$ pulse width in hyper page mode	t_{RAS}	40	200k	40	200k	ns	
$\overline{\text{RAS}}$ hold time from $\overline{\text{CAS}}$ precharge	t_{RHCP}	17	–	21	–	ns	
$\overline{\text{OE}}$ setup time prior to $\overline{\text{CAS}}$	t_{OES}	5	–	5	–	ns	

Parameter	Symbol	Limit Values				Unit	Note
		-400		-40			
		min.	max.	min.	max.		

Hyper Page Mode (EDO) Read-Modify-Write Cycle

Hyper page mode read/write cycle time	t_{PRWC}	55	–	55	–	ns	
CAS precharge to WE delay time	t_{CPWD}	35	–	35	–	ns	

CAS before RAS refresh cycle

CAS setup time	t_{CSR}	5	–	5	–	ns	
CAS hold time	t_{CHR}	5	–	5	–	ns	
RAS to CAS precharge time	t_{RPC}	5	–	5	–	ns	
Write to RAS precharge time	t_{WRP}	10	–	10	–	ns	
Write to RAS hold time	t_{WRH}	10	–	10	–	ns	

CAS-before-RAS counter test cycle

CAS precharge time	t_{CPT}	25	–	25	–	ns	
--------------------	-----------	----	---	----	---	----	--

AC Characteristics ⁵⁾⁶⁾
 $T_A = 0 \text{ to } 70 \text{ }^\circ\text{C}$, $t_T = 2 \text{ ns}$

16E

Parameter	Symbol	Limit Values				Unit	Note
		-45		-50			
		min.	max.	min.	max.		

common parameters

Random read or write cycle time	t_{RC}	79	–	89	–	ns	
$\overline{\text{RAS}}$ precharge time	t_{RP}	30	–	35	–	ns	
$\overline{\text{RAS}}$ pulse width	t_{RAS}	45	10k	50	10k	ns	
$\overline{\text{CAS}}$ pulse width	t_{CAS}	7	10k	8	10k	ns	
$\overline{\text{CAS}}$ precharge time	t_{CP}	7	–	8	–	ns	
Row address setup time	t_{ASR}	0	–	0	–	ns	
Row address hold time	t_{RAH}	7	–	8	–	ns	
Column address setup time	t_{ASC}	0	–	0	–	ns	
Column address hold time	t_{CAH}	7	–	8	–	ns	
$\overline{\text{RAS}}$ to $\overline{\text{CAS}}$ delay time	t_{RCD}	11	33	12	37	ns	
$\overline{\text{RAS}}$ to column address delay	t_{RAD}	9	23	10	25	ns	
$\overline{\text{RAS}}$ hold time	t_{RSH}	12		13	–	ns	
$\overline{\text{CAS}}$ hold time	t_{CSH}	36		40	–	ns	
$\overline{\text{CAS}}$ to $\overline{\text{RAS}}$ precharge time	t_{CRP}	5	–	5	–	ns	
Transition time (rise and fall)	t_T	1	50	1	50	ns	7
Refresh period	t_{REF}	–	16	–	16	ms	
Refresh period (L-version only)	t_{REF}	–	128	–	128	ms	

Read Cycle

Access time from $\overline{\text{RAS}}$	t_{RAC}	–	45	–	50	ns	8, 9
Access time from $\overline{\text{CAS}}$	t_{CAC}	–	12	–	13	ns	8, 9
Access time from column address	t_{AA}	–	22	–	25	ns	8,10
$\overline{\text{OE}}$ access time	t_{OEA}	–	12	–	13	ns	
Column address to $\overline{\text{RAS}}$ lead time	t_{RAL}	23	–	25	–	ns	
Read command setup time	t_{RCS}	0	–	0	–	ns	
Read command hold time	t_{RCH}	0	–	0	–	ns	11
Read command hold time referenced to $\overline{\text{RAS}}$	t_{RRH}	0	–	0	–	ns	11
$\overline{\text{CAS}}$ to output in low-Z	t_{CLZ}	0	–	0	–	ns	8
Output buffer turn-off delay	t_{OFF}	0	12	0	13	ns	12

AC Characteristics (cont'd) ⁵⁾⁶⁾
 $T_A = 0 \text{ to } 70 \text{ }^\circ\text{C}$, $t_T = 2 \text{ ns}$

16E

Parameter	Symbol	Limit Values				Unit	Note
		-45		-50			
		min.	max.	min.	max.		
Output turn-off delay from $\overline{\text{OE}}$	t_{OEZ}	0	12	0	13	ns	12
Data to $\overline{\text{CAS}}$ low delay	t_{DZC}	0	–	0	–	ns	13
Data to $\overline{\text{OE}}$ low delay	t_{DZO}	0	–	0	–	ns	13
$\overline{\text{CAS}}$ high to data delay	t_{CDD}	10	–	10	–	ns	14
$\overline{\text{OE}}$ high to data delay	t_{ODD}	10	–	10	–	ns	14

Write Cycle

Write command hold time	t_{WCH}	7	–	8	–	ns	
Write command pulse width	t_{WP}	7	–	8	–	ns	
Write command setup time	t_{WCS}	0	–	0	–	ns	15
Write command to $\overline{\text{RAS}}$ lead time	t_{RWL}	12	–	13	–	ns	
Write command to $\overline{\text{CAS}}$ lead time	t_{CWL}	12	–	13	–	ns	
Data setup time	t_{DS}	0	–	0	–	ns	16
Data hold time	t_{DH}	7	–	8	–	ns	16

Read-modify-Write Cycle

Read-write cycle time	t_{RWC}	107	–	118	–	ns	
$\overline{\text{RAS}}$ to $\overline{\text{WE}}$ delay time	t_{RWD}	59	–	64	–	ns	15
$\overline{\text{CAS}}$ to $\overline{\text{WE}}$ delay time	t_{CWD}	26	–	27	–	ns	15
Column address to $\overline{\text{WE}}$ delay time	t_{AWD}	36	–	39	–	ns	15
$\overline{\text{OE}}$ command hold time	t_{OEH}	7	–	10	–	ns	

Hyper Page Mode (EDO) Cycle

Hyper page mode (EDO) cycle time	t_{HPC}	18	–	20	–	ns	
Access time from $\overline{\text{CAS}}$ precharge	t_{CPA}	–	25	–	27	ns	7
Output data hold time	t_{COH}	5	–	5	–	ns	
$\overline{\text{RAS}}$ pulse width in EDO mode	t_{RAS}	45	200k	50	200k	ns	
$\overline{\text{CAS}}$ precharge to $\overline{\text{RAS}}$ Delay	t_{RHCP}	25	–	27	–	ns	
$\overline{\text{OE}}$ setup time prior to $\overline{\text{CAS}}$	t_{OES}	5	–	5	–	ns	

AC Characteristics (cont'd) ⁵⁾⁶⁾
 $T_A = 0 \text{ to } 70 \text{ }^\circ\text{C}$, $t_T = 2 \text{ ns}$

16E

Parameter	Symbol	Limit Values				Unit	Note
		-45		-50			
		min.	max.	min.	max.		

Hyper Page Mode (EDO) Read-modify-Write Cycle

Hyper page mode (EDO) read-write cycle time	t_{PRWC}	51	–	58	–	ns	
$\overline{\text{CAS}}$ precharge to $\overline{\text{WE}}$	t_{CPWD}	41	–	41	–	ns	

$\overline{\text{CAS}}$ -before- $\overline{\text{RAS}}$ refresh cycle

$\overline{\text{CAS}}$ setup time	t_{CSR}	5	–	10	–	ns	
$\overline{\text{CAS}}$ hold time	t_{CHR}	10	–	10	–	ns	
$\overline{\text{RAS}}$ to $\overline{\text{CAS}}$ precharge time	t_{RPC}	5	–	5	–	ns	
Write to $\overline{\text{RAS}}$ precharge time	t_{WRP}	10	–	10	–	ns	
Write hold time referenced to $\overline{\text{RAS}}$	t_{WRH}	10	–	10	–	ns	

$\overline{\text{CAS}}$ -before- $\overline{\text{RAS}}$ counter test cycle

$\overline{\text{CAS}}$ precharge time	t_{CPT}	30	–	35	–	ns	
--	-----------	----	---	----	---	----	--

Self Refresh Cycle (L-version)

$\overline{\text{RAS}}$ pulse width	t_{RASS}	100k	–	100k	–	ns	17
$\overline{\text{RAS}}$ precharge	t_{RPS}	110	–	95	–	ns	17
$\overline{\text{CAS}}$ hold time	t_{CHS}	-50	–	-50	–	ns	17

Notes:

- 1) All voltages are referenced to V_{SS} .
- 2) I_{CC1} , I_{CC3} , I_{CC4} and I_{CC6} depend on cycle rate.
- 3) I_{CC1} and I_{CC4} depend on output loading. Specified values are obtained with the output open.
- 4) Address can be changed once or less while $\text{RAS} = V_{il}$. In case of I_{CC4} it can be changed once or less during a hyper page mode (EDO) cycle
- 5) An initial pause of 200 μs is required after power-up followed by 8 $\overline{\text{RAS}}$ cycles of which at least one cycle has to be a refresh cycle, before proper device operation is achieved. In case of using the internal refresh counter, a minimum of 8 $\overline{\text{CAS}}$ -before- $\overline{\text{RAS}}$ initialization cycles instead of 8 $\overline{\text{RAS}}$ cycles are required.
- 6) AC measurements assume $t_T = 2 \text{ ns}$.

- 7) $V_{IH (min.)}$ and $V_{IL (max.)}$ are reference levels for measuring timing of input signals. Transition times are also measured between V_{IH} and V_{IL} .
- 8) Measured with the specified current load and 50 pF at $V_{ol} = 0.8 V$ and $V_{oh} = 2.0 V$. Access time is determined by the latter of t_{RAC} , t_{CAC} , t_{AA} , t_{CPA} , t_{OEA} . t_{CAC} is measured from tristate

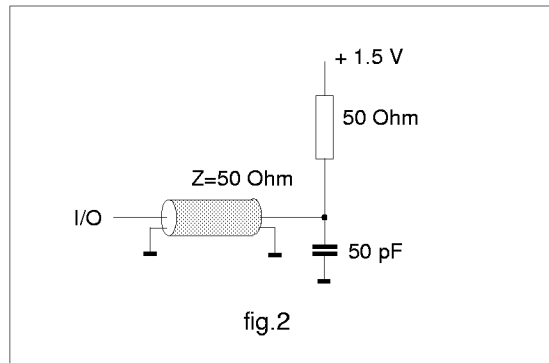

- 9) Operation within the $t_{RCD (max.)}$ limit ensures that $t_{RAC (max.)}$ can be met. $t_{RCD (max.)}$ is specified as a reference point only. If t_{RCD} is greater than the specified $t_{RCD (max.)}$ limit, then access time is controlled by t_{CAC} .
- 10) Operation within the $t_{RAD (max.)}$ limit ensures that $t_{RAC (max.)}$ can be met. $t_{RAD (max.)}$ is specified as a reference point only. If t_{RAD} is greater than the specified $t_{RAD (max.)}$ limit, then access time is controlled by t_{AA} .
- 11) Either t_{RCH} or t_{RRH} must be satisfied for a read cycle.
- 12) $t_{OFF (max.)}$, $t_{OEZ (max.)}$ define the time at which the output achieves the open-circuit conditions and are not referenced to output voltage levels. t_{OFF} is referenced from the rising edge of \overline{RAS} or \overline{CAS} , whichever occurs last.
- 13) Either t_{DZC} or t_{DZO} must be satisfied.
- 14) Either t_{CDD} or t_{ODD} must be satisfied.
- 15) t_{WCS} , t_{RWD} , t_{CWD} and t_{AWD} are not restrictive operating parameters. They are included in the data sheet as electrical characteristics only. If $t_{WCS} > t_{WCS (min.)}$, the cycle is an early write cycle and data out pin will remain open-circuit (high impedance) through the entire cycle; if $t_{RWD} > t_{RWD (min.)}$, $t_{CWD} > t_{CWD (min.)}$ and $t_{AWD} > t_{AWD (min.)}$, the cycle is a read-write cycle and I/O will contain data read from the selected cells. If neither of the above sets of conditions is satisfied, the condition of I/O (at access time) is indeterminate.
- 16) These parameters are referenced to the \overline{CAS} leading edge in early write cycles and to the \overline{WE} leading edge in read-write cycles.
- 17) When using Self Refresh mode, the following refresh operations must be performed to ensure proper DRAM operation:

If row addresses are being refreshed on an evenly distributed manner over the refresh interval using CBR refresh cycles, then only one CBR cycle must be performed immediately after exit from Self Refresh.

If row addresses are being refreshed in any other manner (ROR - Distributed/Burst; or CBR-Burst) over the refresh interval, then a full set of row refreshes must be performed immediately before entry to and immediately after exit from Self Refresh.

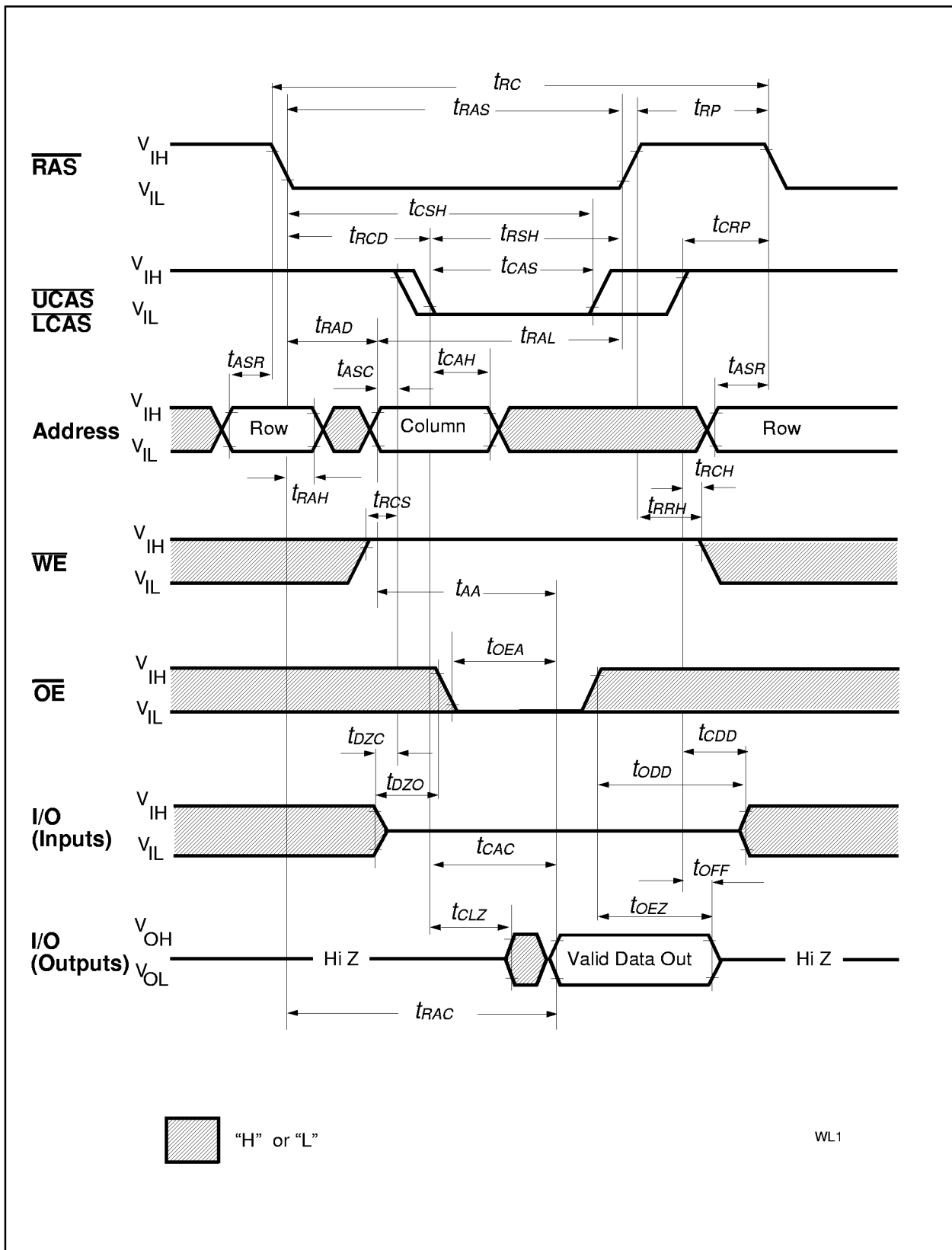

Read Cycle

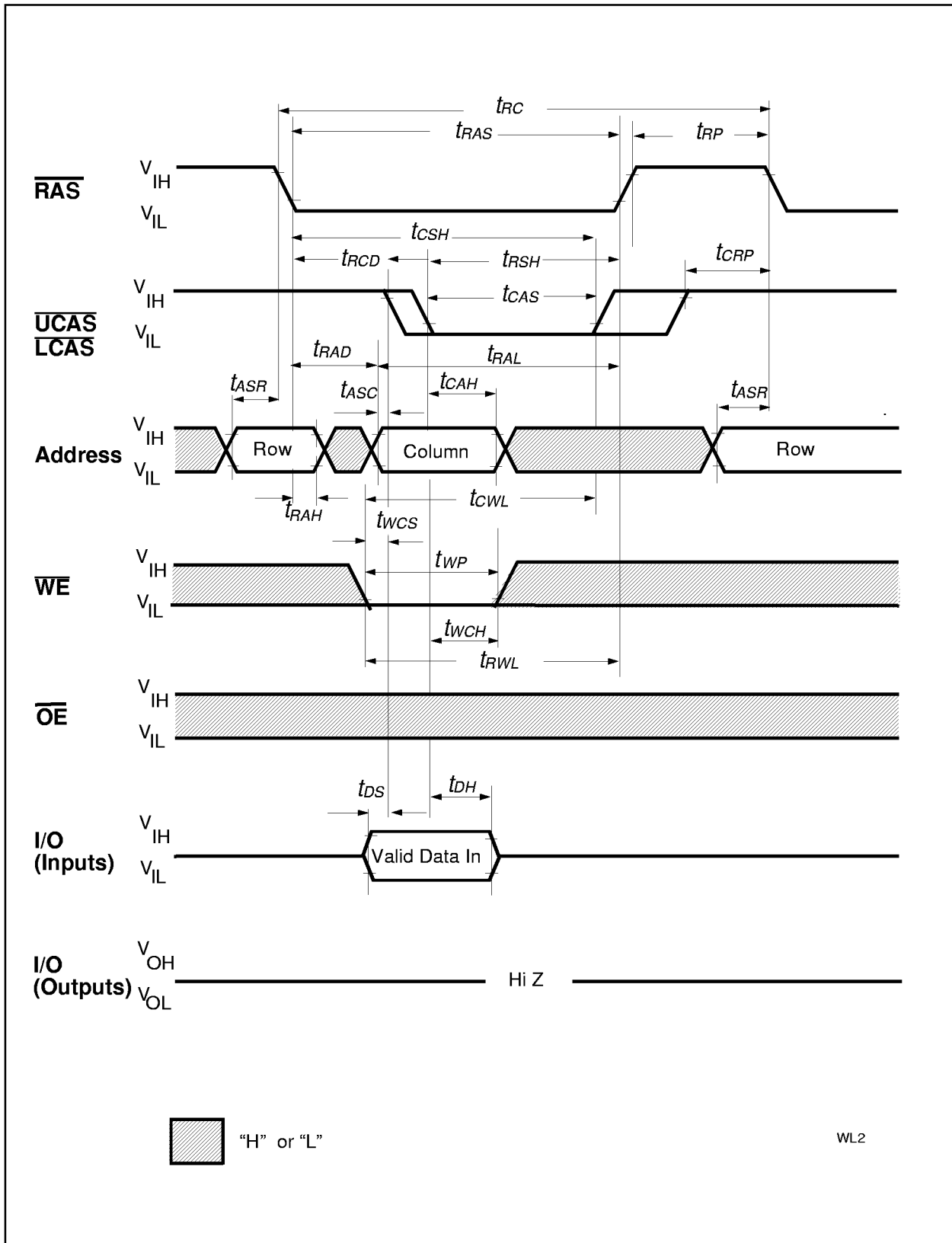

Write Cycle (Early Write)

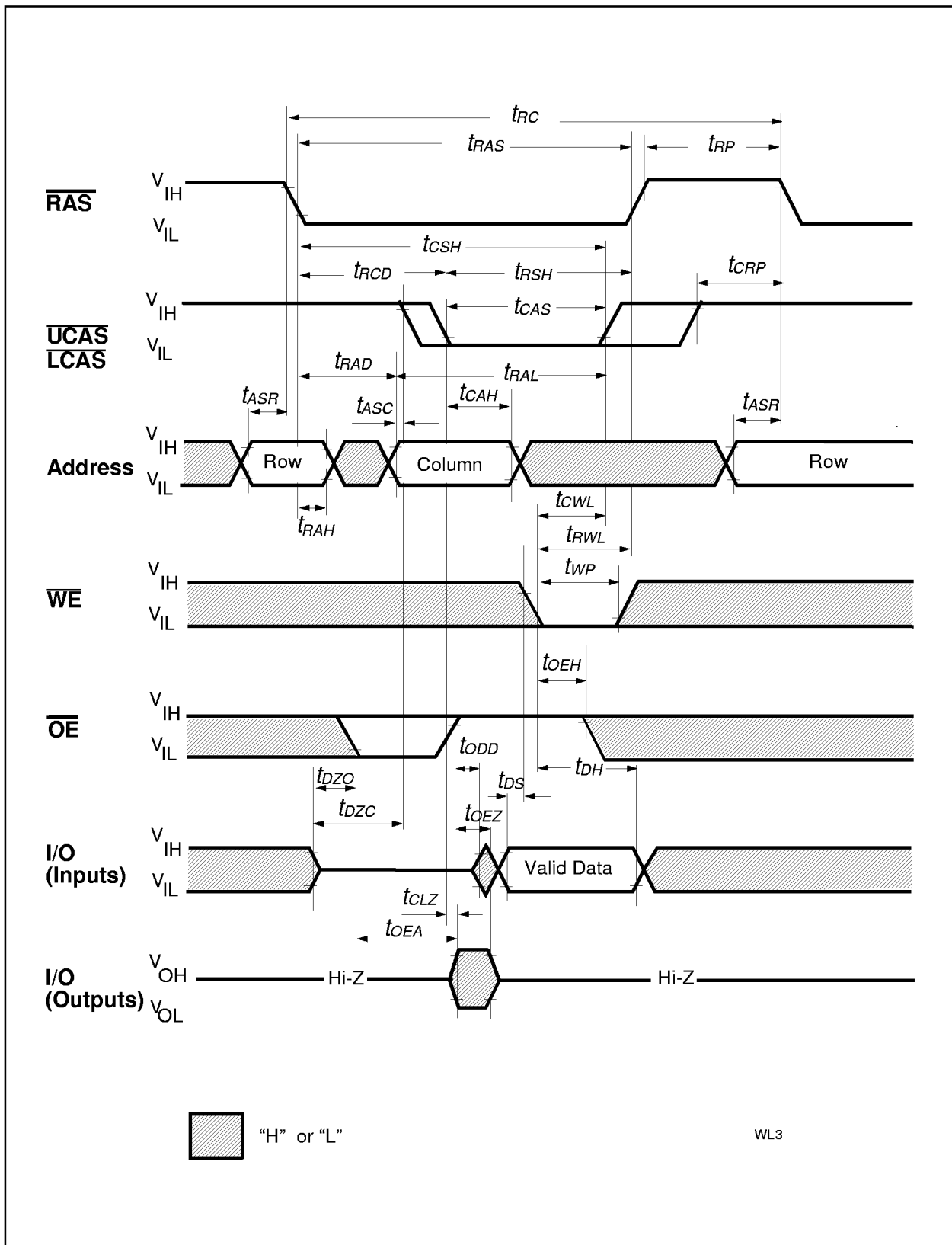

Write Cycle (\overline{OE} Controlled Write)

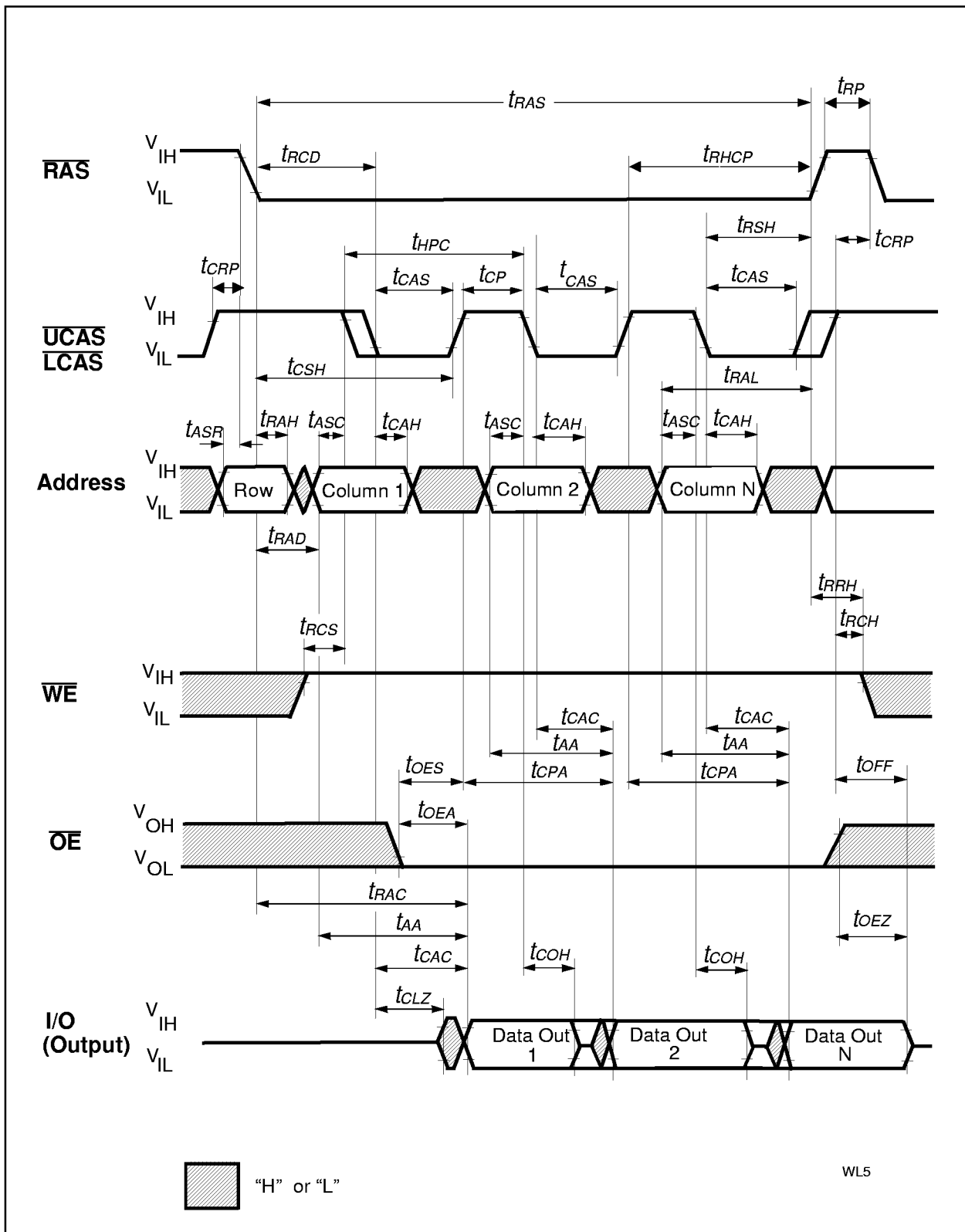

Hyper Page Mode (EDO) Read Cycle

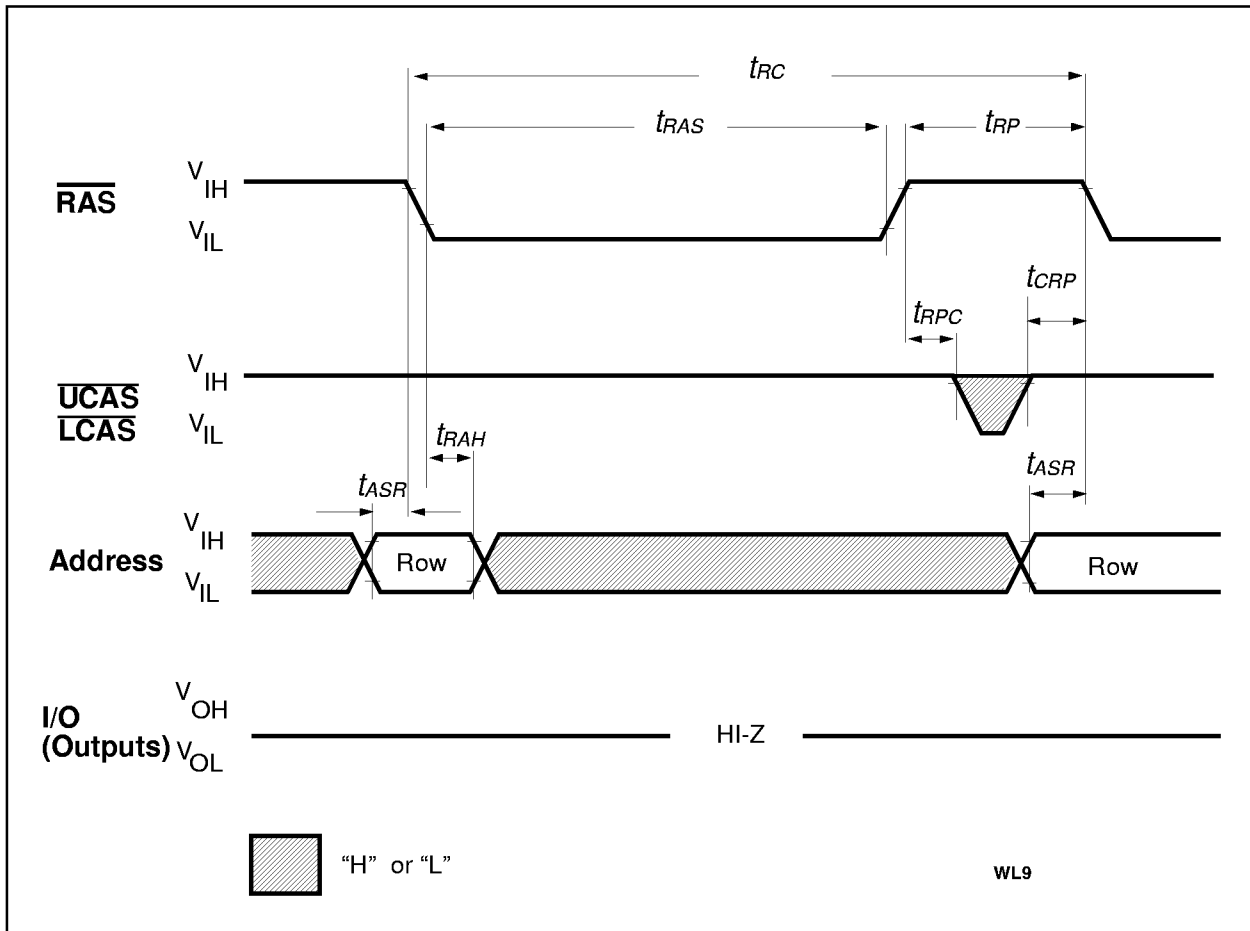

RAS-Only Refresh Cycle

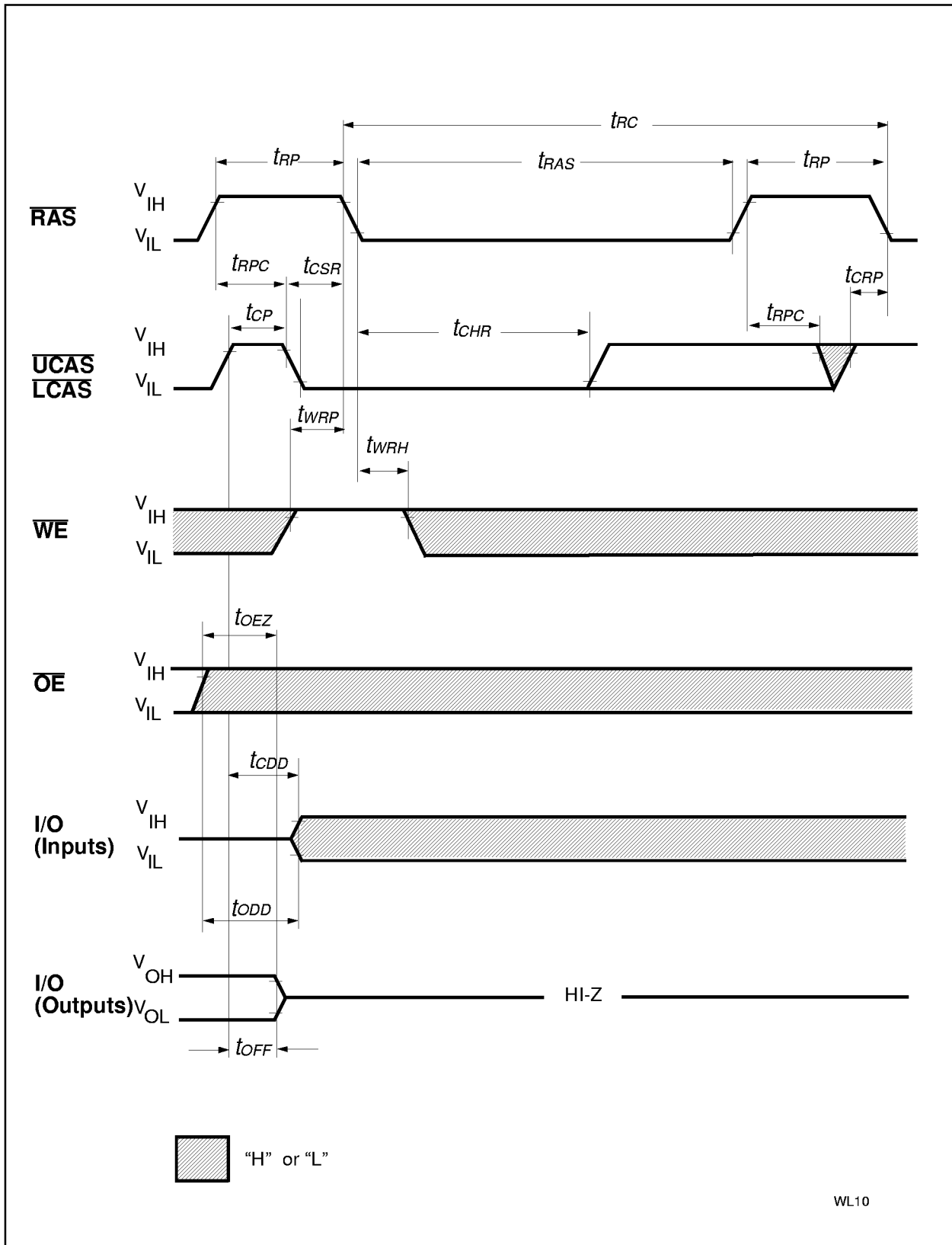

CAS-Before-RAS Refresh Cycle

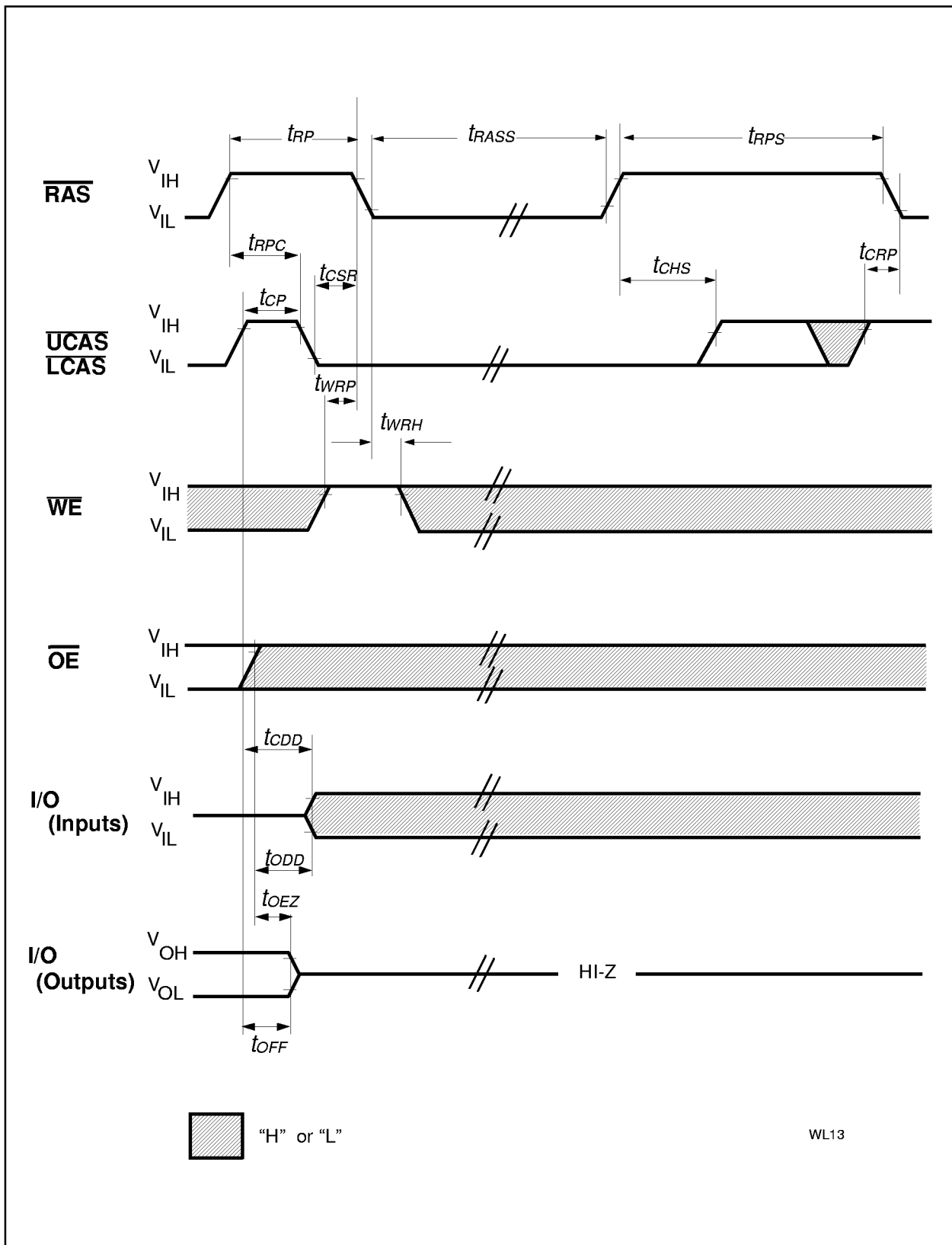

$\overline{\text{CAS}}$ before $\overline{\text{RAS}}$ Self Refresh Cycle

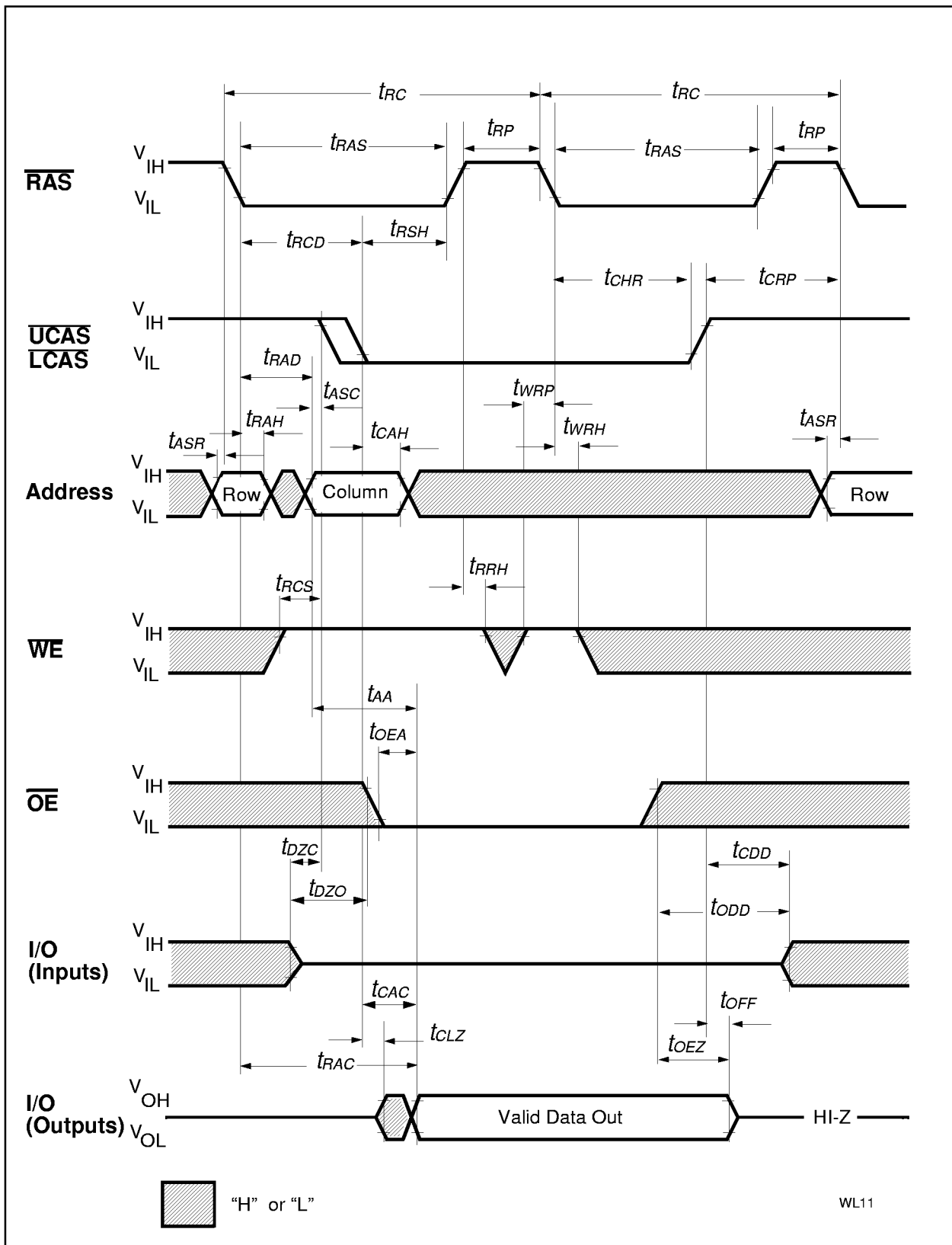

Hidden Refresh Cycle (Read)

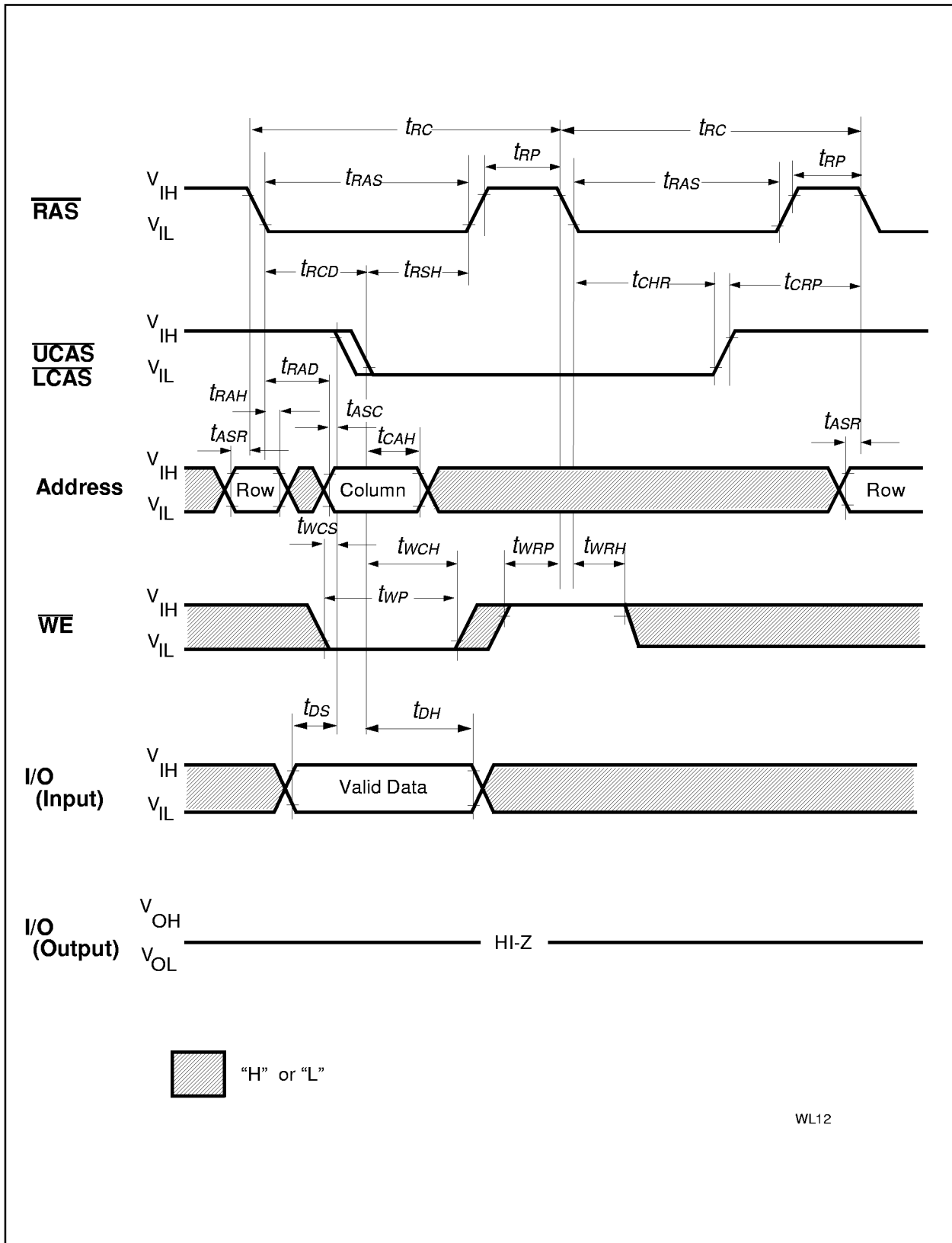

WL12

Hidden Refresh Cycle (Early Write)

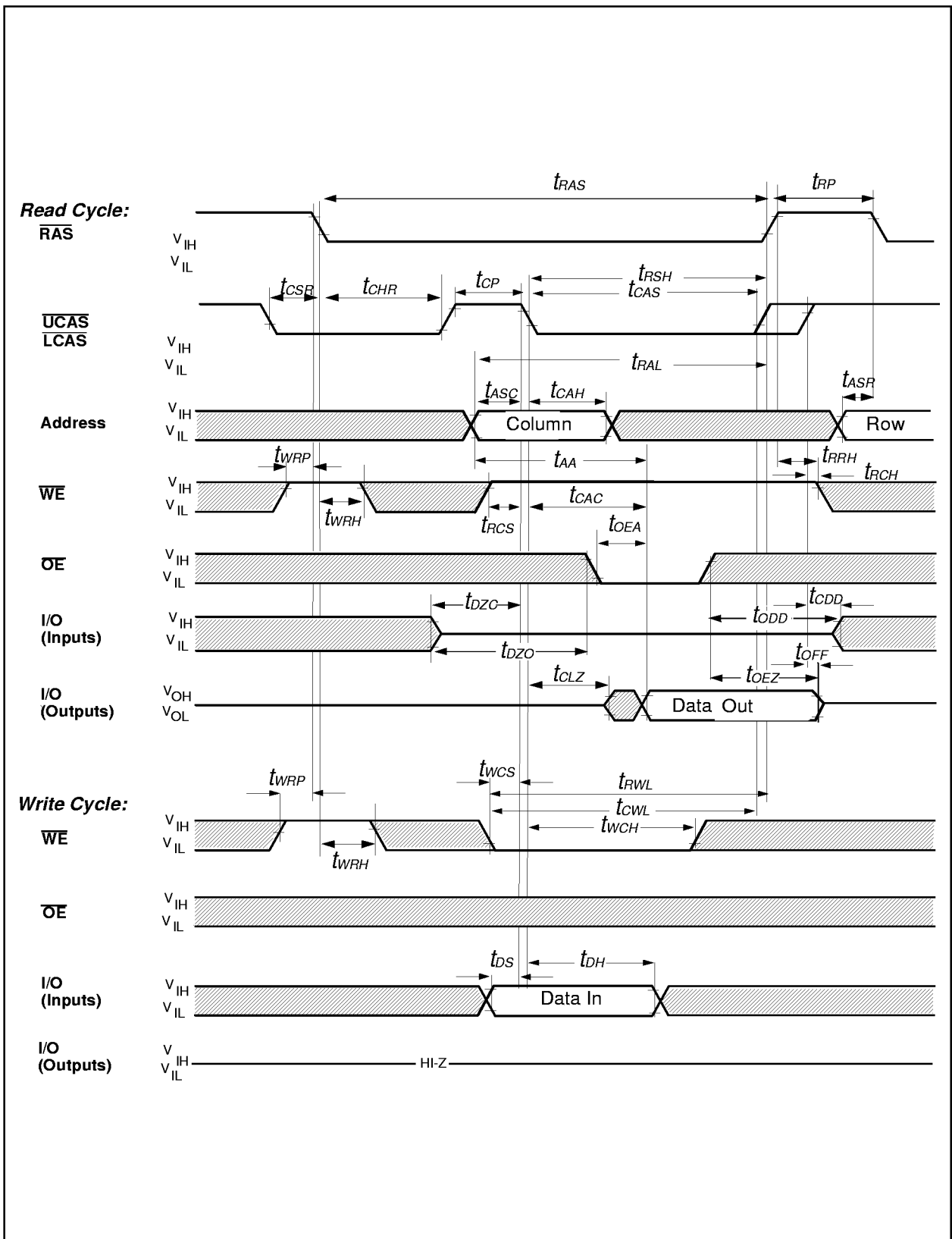

CAS-Before-RAS Refresh Counter Test Cycle

Plastic Package, P-SOJ- 40-1 (SMD)
(Plastic small outline J-lead)

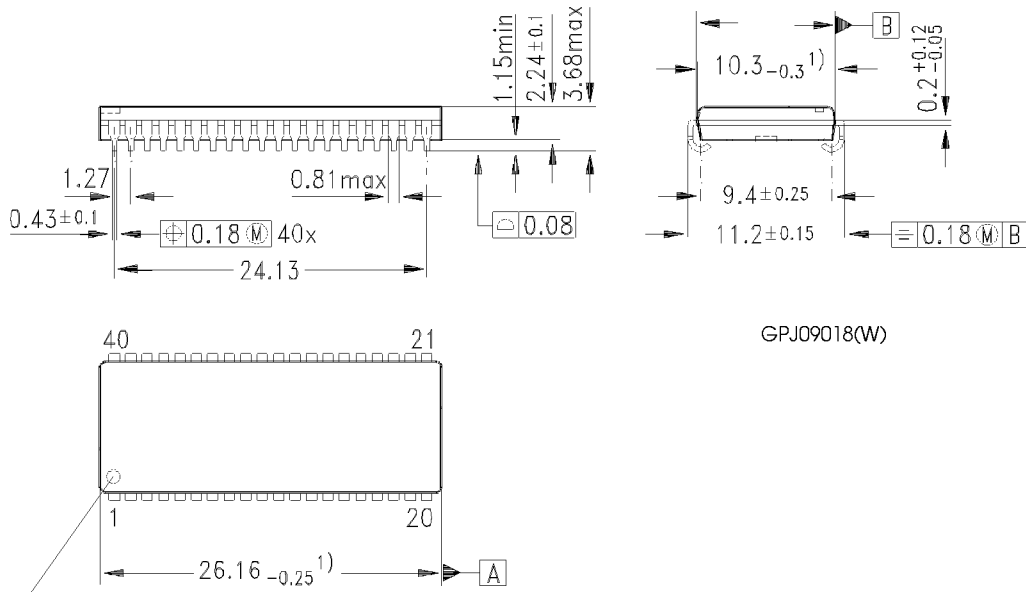

GPJ09018(W)

Index Marking

1) Does not include plastic or metal protrusions of 0.25 max per side

Dimensions in mm

Package Outlines

Revision updates:

Rev. 6.96	First version
Rev. 1.97	ICC1, ICC3 & ICC6 current changed -400 version with +/- 10% VCC