

# AN8837SB

Low power consumption CD-DA head amplifier IC for 3-beam system optical pick-up

## ■ Overview

The AN8837SB is a head amplifier IC for digital servo. It can configure an efficient CD system in combination with the MN6627XX series, and allows a full-automatic adjustment of tracking balance-gain-offset and focus balance-gain-offset with fewer external parts.

## ■ Features

- Operating supply voltage  $V_{CC} = 2.7 \text{ V to } 5.5 \text{ V}$
- Balance adjustment function built-in  
Focus error amp./tracking error amp.
- OFTR/BDO detection
- CROSS detection and vibration detection
- APC amp.

## ■ Applications

- CD player

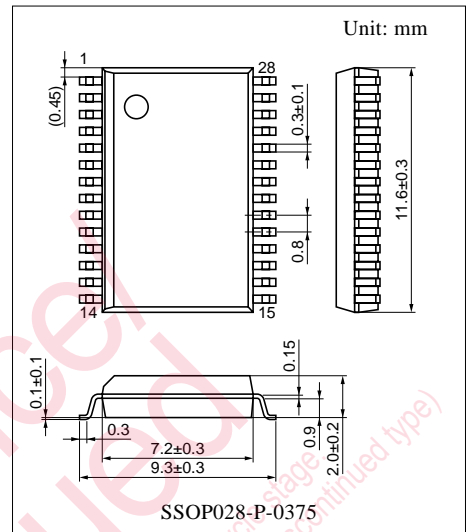

■ Block Diagram

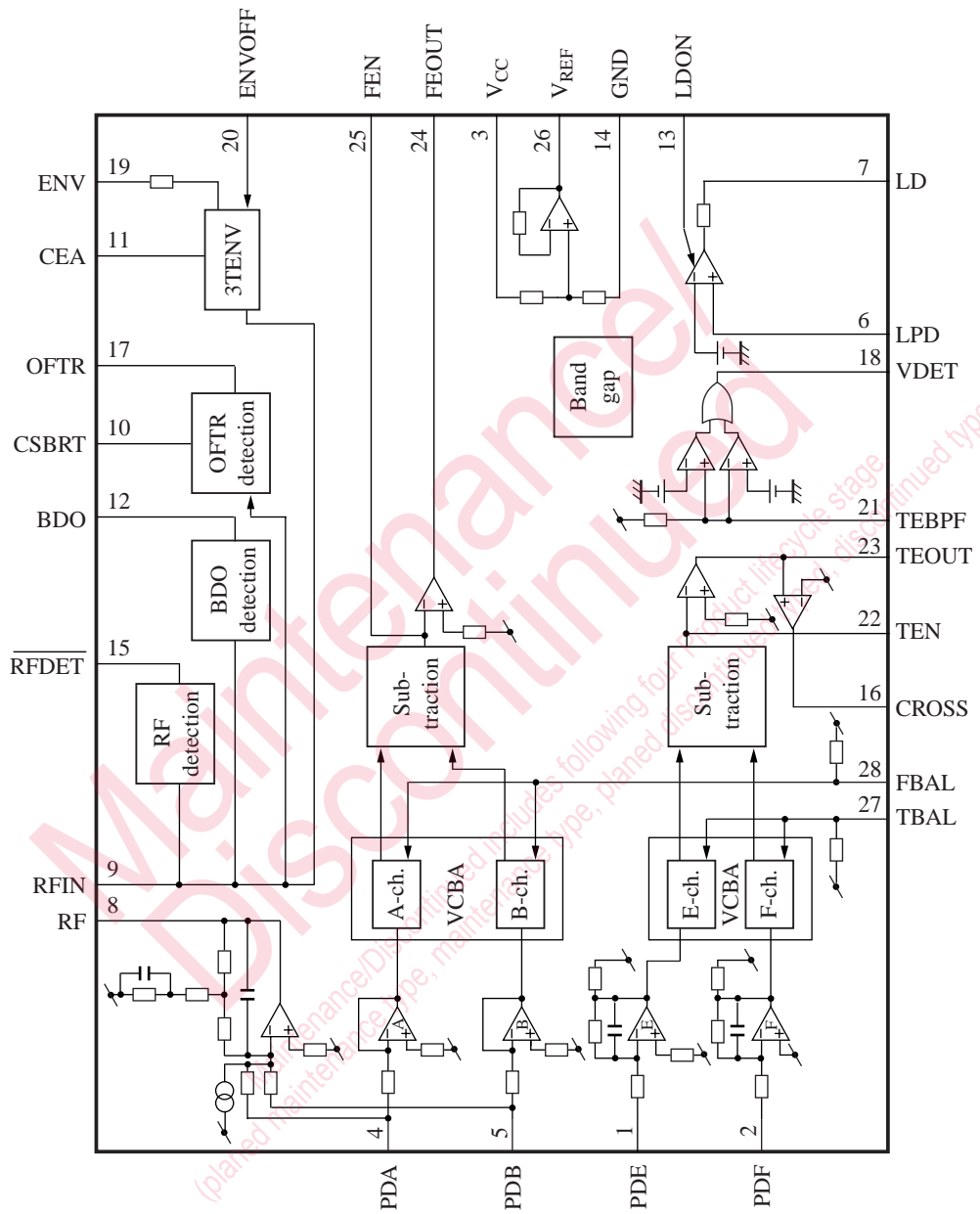

### ■ Pin Descriptions

Pin No.	Description	Pin No.	Description
1	Tracking signal input pin 1	15	NRFDET output pin
2	Tracking signal input pin 2	16	CROSS output pin
3	Power supply pin	17	OFTR output pin
4	Focus signal input pin 1	18	VDET output pin
5	Focus signal input pin 2	19	3TENV output pin
6	APC amp. input pin	20	ENV control pin
7	APC amp. output pin	21	VDET input pin
8	RF adding output pin	22	TE amp. input pin
9	Input pin for the detection circuits	23	TE amp. output pin
10	Capacitor connection pin for OFTR	24	FE amp. output pin
11	Capacitor connection pin for HPF amp.	25	FE amp. input pin
12	BDO output pin	26	V <sub>REF</sub> output pin
13	APC control pin	27	TBAL control pin
14	GND pin	28	FBAL control pin

### ■ Absolute Maximum Ratings

Parameter	Symbol	Rating	Unit
Supply voltage	V <sub>CC</sub>	5.8	V
Supply current	I <sub>CC</sub>	20	mA
Power dissipation	P <sub>D</sub>	116	mW
Operating ambient temperature *	T <sub>opr</sub>	-20 to +75	°C
Storage temperature *	T <sub>stg</sub>	-55 to +125	°C

Note) \*: Except for the operating ambient temperature and storage temperature, all ratings are for T<sub>a</sub> = 25°C.

### ■ Recommended Operating Range

Parameter	Symbol	Range	Unit
Supply voltage	V <sub>CC</sub>	2.7 to 5.5	V

■ Electrical Characteristics at  $T_a = 25^\circ\text{C}$

Parameter	Symbol	Conditions	Min	Typ	Max	Unit
Current consumption with no load	$I_{\text{TOT}}$	$V_{\text{CC}} = 3\text{ V}$	3.8	5.8	7.8	mA
$V_{\text{REF}}$ output pin	$V_{\text{REF}}$	$V_{\text{CC}} = 3\text{ V}$	1.37	1.50	1.63	V
Focus error amplification						
Focus error amp. output offset voltage	$V_{\text{FO-OF}}$	$V_{\text{CC}} = 3\text{ V}$	-100	0	100	mV
Focus error offset balance crosstalk amount	$V_{\text{FO-OFB}}$	$V_{\text{CC}} = 3\text{ V}$ $V_{\text{FB}} = V_{\text{REF}} \pm 0.375\text{ V}$	-120	0	120	mV
Focus error amp. V-V conversion gain	$G_{\text{FO1}}$	$V_{\text{CC}} = 3\text{ V}$ $V_{\text{FB}} = V_{\text{REF}}$	9.6	12.2	14.7	dB
Focus error amp. V-V conversion relative gain	$\Delta G_{\text{FO2}}$	$V_{\text{CC}} = 3\text{ V}$ $V_{\text{FB}} = V_{\text{REF}}$	-1.5	0	1.5	dB
Focus balance variable range 1-H	$B_{\text{FO1-H}}$	$V_{\text{CC}} = 3\text{ V}$ $V_{\text{FB}} = V_{\text{REF}} + 0.375\text{ V}$	1.21	1.31	1.41	—
Focus balance variable range 1-L	$B_{\text{FO1-L}}$	$V_{\text{CC}} = 3\text{ V}$ $V_{\text{FB}} = V_{\text{REF}} - 0.375\text{ V}$	0.48	0.69	0.9	—
Focus balance variable range 2-H	$B_{\text{FO2-H}}$	$V_{\text{CC}} = 3\text{ V}$ $V_{\text{FB}} = V_{\text{REF}} + 0.375\text{ V}$	0.48	0.69	0.9	—
Focus balance variable range 2-L	$B_{\text{FO2-L}}$	$V_{\text{CC}} = 3\text{ V}$ $V_{\text{FB}} = V_{\text{REF}} - 0.375\text{ V}$	1.21	1.31	1.41	—
Focus error amp. frequency characteristics	$G_{\text{FOF}}$	$V_{\text{CC}} = 3\text{ V}$ $f = 3\text{ kHz}, 50\text{ kHz}$	-4.7	-3.2	-1.7	dB
Tracking error amplification						
Tracking error amp. output offset voltage	$V_{\text{TR-OF}}$	$V_{\text{CC}} = 3\text{ V}$	-97	0	97	mV
Tracking error offset balance crosstalk amount	$V_{\text{TR-OFB}}$	$V_{\text{CC}} = 3\text{ V}$ $V_{\text{TB}} = V_{\text{REF}} \pm 0.375\text{ V}$	-120	0	120	mV
Tracking error amp. I-V conversion gain	$R_{\text{TR1}}$	$V_{\text{CC}} = 3\text{ V}$ $V_{\text{TB}} = V_{\text{REF}}$	570	740	910	k $\Omega$
Tracking error amp. I-V conversion relative gain	$\Delta R_{\text{TR2}}$	$V_{\text{CC}} = 3\text{ V}$ $V_{\text{TB}} = V_{\text{REF}}$	-18	0	18	%
Tracking balance variable range 1-H	$B_{\text{TR1-H}}$	$V_{\text{CC}} = 3\text{ V}$ $V_{\text{TB}} = V_{\text{REF}} + 0.375\text{ V}$	0.47	0.68	0.89	—
Tracking balance variable range 1-L	$B_{\text{TR1-L}}$	$V_{\text{CC}} = 3\text{ V}$ $V_{\text{TB}} = V_{\text{REF}} - 0.375\text{ V}$	1.22	1.33	1.44	—
Tracking balance variable range 2-H	$B_{\text{TR2-H}}$	$V_{\text{CC}} = 3\text{ V}$ $V_{\text{TB}} = V_{\text{REF}} + 0.375\text{ V}$	1.22	1.33	1.44	—
Tracking balance variable range 2-L	$B_{\text{TR2-L}}$	$V_{\text{CC}} = 3\text{ V}$ $V_{\text{TB}} = V_{\text{REF}} - 0.375\text{ V}$	0.47	0.68	0.89	—
Tracking error amp. frequency characteristics	$G_{\text{TR1}}$	$V_{\text{CC}} = 3\text{ V}$ $f = 5\text{ kHz}, 100\text{ kHz}$	-5.0	-3.5	-2.0	dB
TEMUTE operation	$V_{23\text{M}}$	$V_{\text{CC}} = 3\text{ V}$	-75	0	75	mV

■ Electrical Characteristics at  $T_a = 25^\circ\text{C}$  (continue)

Parameter	Symbol	Conditions	Min	Typ	Max	Unit
<b>CROSS detection</b>						
CROSS high-level output	$V_{\text{CR-H}}$	$V_{\text{CC}} = 3\text{ V}$ , $V_{\text{TB}} = V_{\text{REF}}$ , $f = 10\text{ kHz}$	2.6	—	—	V
CROSS low-level output	$V_{\text{CR-L}}$	$V_{\text{CC}} = 3\text{ V}$ , $V_{\text{TB}} = V_{\text{REF}}$ , $f = 10\text{ kHz}$	—	—	0.4	V
CROSS comparator hysteresis 1	$\Delta V_{\text{HiS1}}$	$V_{\text{CC}} = 3\text{ V}$	35	50	65	mV
CROSS comparator hysteresis 2	$\Delta V_{\text{HiS2}}$	$V_{\text{CC}} = 3\text{ V}$	-57	-42	-27	mV
<b>RF amplification</b>						
RF amp. offset voltage	$V_{\text{RF-OF}}$	$V_{\text{CC}} = 3\text{ V}$	-910	-710	-510	mV
RF amp. transfer gain	$G_{\text{RF}}$	$V_{\text{CC}} = 3\text{ V}$	7.7	9.3	10.9	dB
RF amp. relative transfer gain	$\Delta G_{\text{RF}}$	$V_{\text{CC}} = 3\text{ V}$	-0.8	0	0.8	dB
RF amp. frequency characteristics *	$G_{\text{RFF}}$	$V_{\text{CC}} = 3\text{ V}$ $f = 500\text{ kHz}, 3\text{ MHz}$	-3.7	-1.5	0.7	dB
RF amp. relative frequency characteristics *	$\Delta G_{\text{RFF}}$	$V_{\text{CC}} = 3\text{ V}$ $f = 500\text{ kHz}, 3\text{ MHz}$	-1.0	0	1.0	dB
RF amp. EQ characteristics 1 *	$G_{\text{EQ1}}$	$V_{\text{CC}} = 3\text{ V}$ $f = 500\text{ kHz}, 1.5\text{ MHz}$	0.5	1.7	3.6	dB
RF amp. EQ characteristics 2 *	$G_{\text{EQ2}}$	$V_{\text{CC}} = 3\text{ V}$ $f = 100\text{ kHz}, 500\text{ kHz}$	-3.5	-2.0	-0.5	dB
<b>RF detection</b>						
RFDET detection operation	$V_{\text{NRF}}$	$V_{\text{CC}} = 3\text{ V}$ , $f = 500\text{ kHz}$	88	132	176	mV[p-p]
RFDET high-level	$V_{\text{NRF-H}}$	$V_{\text{CC}} = 3\text{ V}$ , $f = 500\text{ kHz}$	2.6	—	—	V
RFDET low-level	$V_{\text{NRF-L}}$	$V_{\text{CC}} = 3\text{ V}$ , $f = 500\text{ kHz}$	—	—	0.4	V
<b>BDO</b>						
BDO detection level	$V_{\text{BDO}}$	$V_{\text{CC}} = 3\text{ V}$	-70	-44	-18	mV
BDO high-level	$V_{\text{BDO-H}}$	$f = 5\text{ kHz}$ , $170\text{ mV[p-p]}$ , $V_{\text{CC}} = 3\text{ V}$	2.6	—	—	V
BDO low-level	$V_{\text{BDO-L}}$	$f = 5\text{ kHz}$ , $170\text{ mV[p-p]}$ , $V_{\text{CC}} = 3\text{ V}$	—	—	0.4	V
<b>OFTR</b>						
OFTR detection current	$G_{\text{FAGC1}}$	$V_{\text{CC}} = 3\text{ V}$	1.03	1.45	1.87	$\mu\text{A}$
OFTR high-level	$V_{\text{OFT-H}}$	$V_{\text{CC}} = 3\text{ V}$ , $f = 5\text{ kHz}$ , $700\text{ mV[p-p]}$	2.6	—	—	V
OFTR low-level	$V_{\text{OFT-L}}$	$V_{\text{CC}} = 3\text{ V}$ , $f = 5\text{ kHz}$ , $700\text{ mV[p-p]}$	—	—	0.4	V
<b>LD APC</b>						
APC operating voltage	$V_{\text{APC}}$	$V_{\text{CC}} = 3\text{ V}$	147	170	193	mV

Note) \*: The values mentioned above are subject to change according to the state of a printed circuit board, a socket, etc.

**■ Electrical Characteristics at  $T_a = 25^\circ\text{C}$  (continued)**

Parameter	Symbol	Conditions	Min	Typ	Max	Unit
<b>VDET</b>						
VDET detection level 1	$V_{\text{DET1}}$	$V_{\text{CC}} = 3 \text{ V}$	38	51	64	mV
VDET detection level 2	$V_{\text{DET2}}$	$V_{\text{CC}} = 3 \text{ V}$	-64	-51	-38	mV
VDET high-level	$V_{\text{DET-H}}$	$V_{\text{CC}} = 3 \text{ V}$	2.6	—	—	V
VDET low-level	$V_{\text{DET-L}}$	$V_{\text{CC}} = 3 \text{ V}$	—	—	0.4	V
TEBPF input impedance	$Z_{\text{TEB}}$	$V_{\text{CC}} = 3 \text{ V}$	140	200	260	k $\Omega$
<b>3TENV</b>						
ENV amp. offset voltage	$V_{\text{ENV-OFF}}$	$V_{\text{CC}} = 3 \text{ V}$	-75	0	75	mV
CEA-ENV transfer characteristics	$G_{\text{CENV}}$	$V_{\text{CC}} = 3 \text{ V}$	6	7.6	9.2	times
CEA input impedance	$Z_{\text{CEA}}$	$V_{\text{CC}} = 3 \text{ V}$	6.8	8.7	10.6	k $\Omega$
ENV output impedance	$Z_{\text{ENV}}$	$V_{\text{CC}} = 3 \text{ V}$	6.2	8.0	9.8	k $\Omega$
ENV amp. operation	$V_{\text{OP-ENV}}$	$V_{\text{CC}} = 3 \text{ V}$ , $f = 800 \text{ kHz}$ AM modulation	70	110	150	mV[p-p]
ENV amp. no-operation	$V_{\text{ENV-OFF}}$	$V_{\text{CC}} = 3 \text{ V}$ , $f = 800 \text{ kHz}$ AM modulation	-15	0	15	mV[p-p]
<b>RF amplification</b>						
RF-amp. output impedance	$Z_{\text{RFOS}}$	$V_{\text{CC}} = 3 \text{ V}$	—	—	29	$\Omega$

■ Application Circuit Example

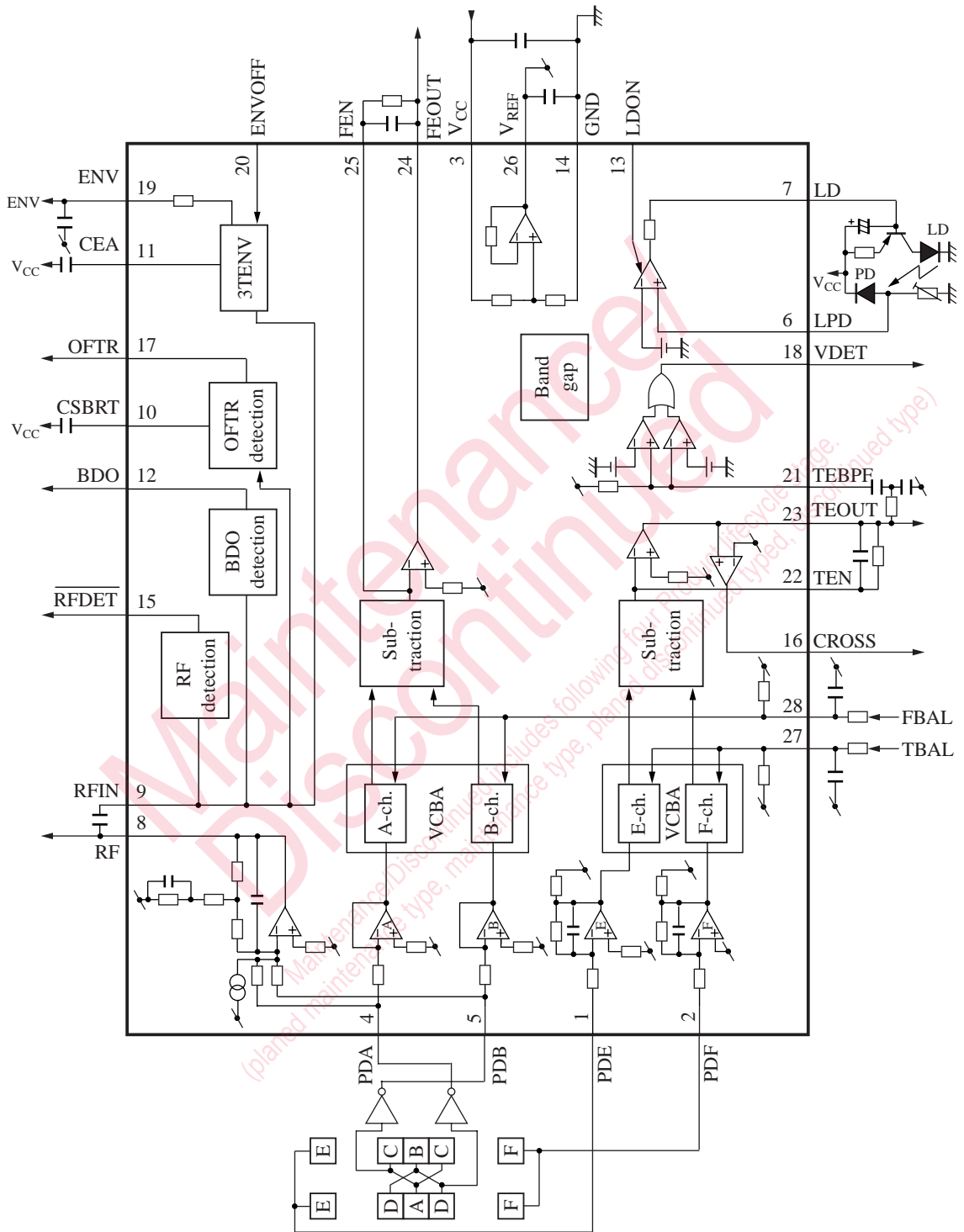

## Request for your special attention and precautions in using the technical information and semiconductors described in this book

- (1) If any of the products or technical information described in this book is to be exported or provided to non-residents, the laws and regulations of the exporting country, especially, those with regard to security export control, must be observed.
- (2) The technical information described in this book is intended only to show the main characteristics and application circuit examples of the products, and no license is granted under any intellectual property right or other right owned by our company or any other company. Therefore, no responsibility is assumed by our company as to the infringement upon any such right owned by any other company which may arise as a result of the use of technical information described in this book.
- (3) The products described in this book are intended to be used for standard applications or general electronic equipment (such as office equipment, communications equipment, measuring instruments and household appliances).  
Consult our sales staff in advance for information on the following applications:
  - Special applications (such as for airplanes, aerospace, automobiles, traffic control equipment, combustion equipment, life support systems and safety devices) in which exceptional quality and reliability are required, or if the failure or malfunction of the products may directly jeopardize life or harm the human body.
  - Any applications other than the standard applications intended.
- (4) The products and product specifications described in this book are subject to change without notice for modification and/or improvement. At the final stage of your design, purchasing, or use of the products, therefore, ask for the most up-to-date Product Standards in advance to make sure that the latest specifications satisfy your requirements.
- (5) When designing your equipment, comply with the range of absolute maximum rating and the guaranteed operating conditions (operating power supply voltage and operating environment etc.). Especially, please be careful not to exceed the range of absolute maximum rating on the transient state, such as power-on, power-off and mode-switching. Otherwise, we will not be liable for any defect which may arise later in your equipment.
  - Even when the products are used within the guaranteed values, take into the consideration of incidence of break down and failure mode, possible to occur to semiconductor products. Measures on the systems such as redundant design, arresting the spread of fire or preventing glitch are recommended in order to prevent physical injury, fire, social damages, for example, by using the products.
- (6) Comply with the instructions for use in order to prevent breakdown and characteristics change due to external factors (ESD, EOS, thermal stress and mechanical stress) at the time of handling, mounting or at customer's process. When using products for which damp-proof packing is required, satisfy the conditions, such as shelf life and the elapsed time since first opening the packages.
- (7) This book may be not reprinted or reproduced whether wholly or partially, without the prior written permission of Matsushita Electric Industrial Co., Ltd.