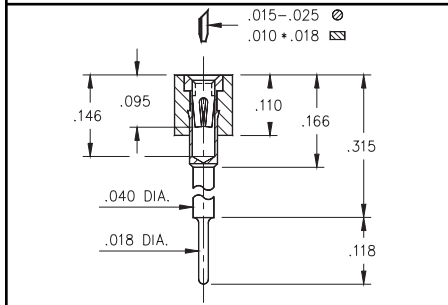
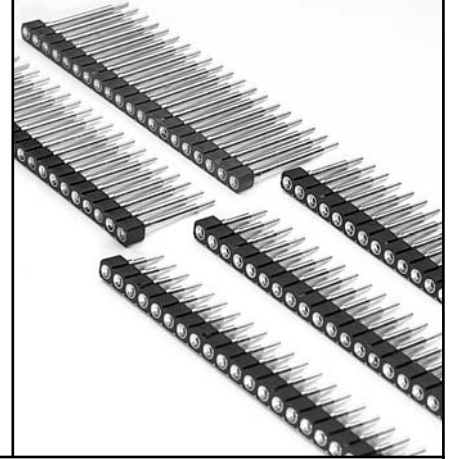
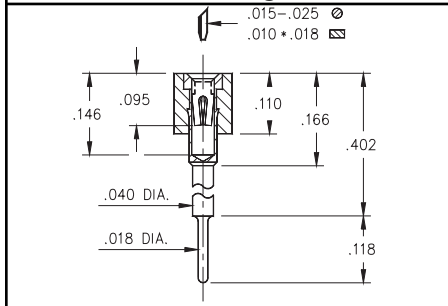

**Fig. 1**

- Elevated socket strips are available in 5 different heights.
  - 316...006 uses pin # 0153-1
  - 316...003 uses pin # 0153-2
  - 316...007 uses pin # 0153-3
  - 316...008 uses pin # 0153-4
  - 316...001 uses pin # 0153-5
- Hi-Rel, 4-finger BeCu #30 clip rated at 3 amps. See page 208 for details.



**Fig. 2**



**Fig. 3**

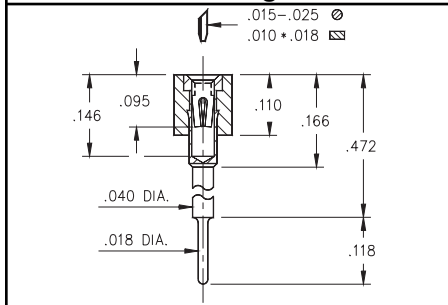

**Fig. 4**

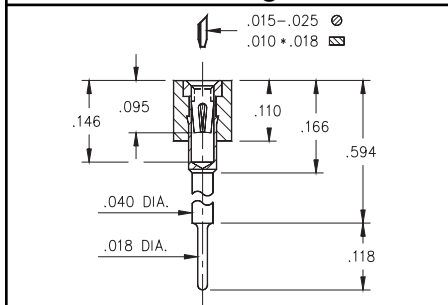

**Fig. 5**

**Ordering Information**

<b>Fig. 1</b>	<b>Series 316...006</b>	<b>Standoff Height = .236</b>
	316-XX-1__-41-006	Specify # of pins → 01-64
<b>Fig. 2</b>	<b>Series 316...003</b>	<b>Standoff Height = .315</b>
	316-XX-1__-41-003	Specify # of pins → 01-64
<b>Fig. 3</b>	<b>Series 316...007</b>	<b>Standoff Height = .402</b>
	316-XX-1__-41-007	Specify # of pins → 01-64
<b>Fig. 4</b>	<b>Series 316...008</b>	<b>Standoff Height = .472</b>
	316-XX-1__-41-008	Specify # of pins → 01-64
<b>Fig. 5</b>	<b>Series 316...001</b>	<b>Standoff Height = .594</b>
	316-XX-1__-41-001	Specify # of pins → 01-64

***XX= Plating Code  
See Below***

***For High Temperature  
Insulators Add '100'  
To End Of  
Part Numbers***

SPECIFY PLATING CODE XX=			<b>93</b>	
Sleeve (Pin)			200μ" Sn/Pb	
Contact (Clip)			30μ" Au	