



# R1QCA7236ABB / R1QCA7218ABB R1QFA7236ABB / R1QFA7218ABB

72-Mbit DDRII+ SRAM  
4-word Burst

R10DS0171EJ0011

Rev. 0.11  
2013.01.15

## Description

The R1Q#A7236 is a 2,097,152-word by 36-bit and the R1Q#A7218 is a 4,194,304-word by 18-bit synchronous double data rate static RAM fabricated with advanced CMOS technology using full CMOS six-transistor memory cell. It integrates unique synchronous peripheral circuitry and a burst counter. All input registers are controlled by an input clock pair (K and /K) and are latched on the positive edge of K and /K. These products are suitable for applications which require synchronous operation, high speed, low voltage, high density and wide bit configuration. These products are packaged in 165-pin plastic FBGA package.

# = C: Read Latency =2.5, w/o ODT

# = F: Read Latency =2.5, w/ ODT

## Features

### ■ Power Supply

- 1.8 V for core ( $V_{DD}$ ), 1.4 V to  $V_{DD}$  for I/O ( $V_{DDQ}$ )

### ■ Clock

- Fast clock cycle time for high bandwidth
- Two input clocks (K and /K) for precise DDR timing at clock rising edges only
- Two output echo clocks (CQ and /CQ) simplify data capture in high-speed systems
- Clock-stop capability with  $\mu$ s restart

### ■ I/O

- Common data input/output bus
- Pipelined double data rate operation
- HSTL I/O
- User programmable output impedance
- DLL/PLL circuitry for wide output data valid window and future frequency scaling
- Data valid pin (QVLD) to indicate valid data on the output

### ■ Function

- Four-tick burst for reduced address frequency
- Internally self-timed write control
- Simple control logic for easy depth expansion
- JTAG 1149.1 compatible test access port

### ■ Package

- 165 FBGA package (13 x 15 x 1.4 mm)

- Notes:
1. QDR RAMs and Quad Data Rate RAMs comprise a new family of products developed by Cypress Semiconductor, IDT, Samsung, and Renesas Electronics Corp. (QDR Co-Development Team)
  2. The specifications of this device are subject to change without notice. Please contact your nearest Renesas Electronics Sales Office regarding specifications.
  3. Refer to  
"[http://www.renesas.com/products/memory/fast\\_sram/qdr\\_sram/index.jsp](http://www.renesas.com/products/memory/fast_sram/qdr_sram/index.jsp)"  
for the latest and detailed information.
  4. Descriptions about x9 parts in this datasheet are just for reference.

Part Number Definition

Column No.	0	1	2	3	4	5	6	7	8	9	10	11	-	12	13	14	15	16
Example	R	1	Q	C	A	7	2	1	8	A	B	B	-	1	9	R	B	0
The above part number is just example for 72M DDRII+ B4 x18 533MHz, 13x15mm PKG, Pb-free part.																		

No.	-	Comments	No.	-	Comments	No.	-	Comments
0-1	R1	Renesas Memory Prefix	4	A	Vdd = 1.8 V	12-13	60	Frequency = 167MHz
2-3	Q2	QDR II B2 <sup>[*1]</sup> (L15) <sup>[*2]</sup>	5-6	36	Density = 36Mb		50	Frequency = 200MHz
	Q3	QDR II B4 (L15)		72	Density = 72Mb		40	Frequency = 250MHz
	Q4	DDR II B2 (L15)		44	Density = 144Mb		36	Frequency = 275MHz
	Q5	DDR II B4 (L15)		88	Density = 288Mb		33	Frequency = 300MHz
	Q6	DDR II B2 SIO <sup>[*3]</sup> (L15)	7-8	09	Data width = 9bit		30	Frequency = 333MHz
	QA	QDR II+ B4 L25 <sup>[*2]</sup>		18	Data width = 18bit		27	Frequency = 375MHz
	QB	DDR II+ B2 L25		36	Data width = 36bit		25	Frequency = 400MHz
	QC	DDR II+ B4 L25	9	R	1st Generation		22	Frequency = 450MHz
	QD	QDR II+ B4 L25 w/ODT <sup>[*4]</sup>		A	2nd Generation		20	Frequency = 500MHz
	QE	DDR II+ B2 L25 w/ODT		B	3rd Generation		19	Frequency = 533MHz
	QF	DDR II+ B4 L25 w/ODT		C	4th Generation		18	Frequency = 550MHz
	QG	QDR II+ B4 L20		D	5th Generation	14	R	Commercial temp. Ta range = 0°C to 70°C
	QH	DDR II+ B2 L20		E	6th Generation		I	Industrial temp. Ta range = -40°C to 85°C
	QJ	DDR II+ B4 L20		F	7th Generation		A	Pb and Tray
	QK	QDR II+ B4 L20 w/ODT	10-11	BG	PKG= BGA 15x17 mm	15	B	Pb-free and Tray
	QL	DDR II+ B2 L20 w/ODT		BB	PKG= BGA 13x15 mm		T	Pb and Tape&Reel
QM	DDR II+ B4 L20 w/ODT	-	-	-	S	Pb-free and Tape&Reel		
QN	QDR II+ B2 L20				16	0 to 9, A to Z or None	Renesas internal use	
QP	QDR II+ B2 L20 w/ODT							
-	-	-	-	-	-	-	-	-

- Note1: [\*1] B=Burst length (B2: Burst length=2, B4: Burst length=4)  
[\*2] L=Read Latency (L15: Read Latency = 1.5 cycle, L20: 2.0 cycle, L25: 2.5 cycle)  
[\*3] SIO=Separate I/O  
[\*4] ODT=On die termination
- Note2: Package Marking Name  
Pb parts: Marking Name = Part Number(0-14)  
Pb-free parts: Marking Name = Part Number(0-14) + "PB-F"  
(Example) R1QAA4436RBG-20R ----- Pb parts  
R1QAA4436RBG-20R PB-F ----- Pb-free parts
- Note3: Pb : RoHS Compliance Level = 5/6  
Pb-free: RoHS Compliance Level = 6/6
- Note4: R1Q\*A series support both "Commercial" and "Industrial" temperatures  
by "Industrial" temperature parts.

72M QDR/DDR SRAM (R1Q\*A72 Series) Lineup

- Renesas supports or plans to support the parts listed below.

No	Product Type	Burst Length	Latency (Cycle)	ODT	Organi- zation	Frequency (max) (MHz)	QDR II+ / DDR II+						QDR II / DDR II					
							533	500	450	400	375	333	333	300	250	200		
							Cycle Time (min) (ns)						1.875	2.00	2.22	2.50	2.66	3.00
Part Number ↓ yy →						-19	-20	-22	-25	-27	-30	-30	-33	-40	-50			
1	QDRII	B2	1.5	No	x 9	R1Q 2 A72 09 ABv-yy									-40	-50		
2					x18	R1Q 2 A72 18 ABv-yy											-40	-50
3					x36	R1Q 2 A72 36 ABv-yy												
5		B4			x18	R1Q 3 A72 18 ABv-yy												
6					x36	R1Q 3 A72 36 ABv-yy												
8					x18	R1Q 4 A72 18 ABv-yy												
9	DDRII	B2	x36	R1Q 4 A72 36 ABv-yy														
11		B4	x18	R1Q 5 A72 18 ABv-yy														
12			x36	R1Q 5 A72 36 ABv-yy														
14	DDRII SIO	B2	x18	R1Q 6 A72 18 ABv-yy														
15			x36	R1Q 6 A72 36 ABv-yy														
17	QDRII+	B4	2.5	No	x18	R1Q A A72 18 ABv-yy	-19	-20	-22									
18					x36	R1Q A A72 36 ABv-yy												
20	DDRII+	B2			x18	R1Q B A72 18 ABv-yy	-19	-20	-22									
21					x36	R1Q B A72 36 ABv-yy												
23		B4			x18	R1Q C A72 18 ABv-yy	-19	-20	-22									
24					x36	R1Q C A72 36 ABv-yy												
26	QDRII+	B4	x18	R1Q D A72 18 ABv-yy	-19	-20	-22											
27			x36	R1Q D A72 36 ABv-yy														
29	DDRII+	B2	x18	R1Q E A72 18 ABv-yy	-19	-20	-22											
30			x36	R1Q E A72 36 ABv-yy														
32		B4	x18	R1Q F A72 18 ABv-yy	-19	-20	-22											
33			x36	R1Q F A72 36 ABv-yy														
35	QDRII+	B4	2.0	No	x18	R1Q G A72 18 ABv-yy				-25								
36					x36	R1Q G A72 36 ABv-yy												
38	DDRII+	B2			x18	R1Q H A72 18 ABv-yy					-25							
39					x36	R1Q H A72 36 ABv-yy												
41		B4			x18	R1Q J A72 18 ABv-yy						-25						
42					x36	R1Q J A72 36 ABv-yy												
44	QDRII+	B4	x18	R1Q K A72 18 ABv-yy						-25								
45			x36	R1Q K A72 36 ABv-yy														
47	DDRII+	B2	x18	R1Q L A72 18 ABv-yy						-25								
48			x36	R1Q L A72 36 ABv-yy														
50		B4	x18	R1Q M A72 18 ABv-yy							-25							
51			x36	R1Q M A72 36 ABv-yy														

Notes:

- "v" represents the package size. If "v" = "G" then size is 15 x 17 mm, and if "v" = "B" then 13 x 15 mm.
- "yy" represents the speed bin. "R1QAA7236ABB-20" can operate at 500 MHz(max) of frequency, for example.
- The part which is not listed above is not supported, as of the day when this datasheet was issued, in spite of the existence of the part number or datasheet.

Pin Arrangement

R1Q5A7236 (Top) / R1QC(J)A7236 (Mid) / R1QF(M)A7236 (Bottom)

	1	2	3	4	5	6	7	8	9	10	11
A	/CQ	NC	SA	R-/W	/BW2	/K	/BW1	/LD	SA	SA	CQ
B	NC	DQ27	DQ18	SA	/BW3	K	/BW0	SA	NC	NC	DQ8
C	NC	NC	DQ28	V <sub>SS</sub>	SA	SA0 NC NC	SA1 NC NC	V <sub>SS</sub>	NC	DQ17	DQ7
D	NC	DQ29	DQ19	V <sub>SS</sub>	V <sub>SS</sub>	V <sub>SS</sub>	V <sub>SS</sub>	V <sub>SS</sub>	NC	NC	DQ16
E	NC	NC	DQ20	V <sub>DDQ</sub>	V <sub>SS</sub>	V <sub>SS</sub>	V <sub>SS</sub>	V <sub>DDQ</sub>	NC	DQ15	DQ6
F	NC	DQ30	DQ21	V <sub>DDQ</sub>	V <sub>DD</sub>	V <sub>SS</sub>	V <sub>DD</sub>	V <sub>DDQ</sub>	NC	NC	DQ5
G	NC	DQ31	DQ22	V <sub>DDQ</sub>	V <sub>DD</sub>	V <sub>SS</sub>	V <sub>DD</sub>	V <sub>DDQ</sub>	NC	NC	DQ14
H	/DOFF	V <sub>REF</sub>	V <sub>DDQ</sub>	V <sub>DDQ</sub>	V <sub>DD</sub>	V <sub>SS</sub>	V <sub>DD</sub>	V <sub>DDQ</sub>	V <sub>DDQ</sub>	V <sub>REF</sub>	ZQ
J	NC	NC	DQ32	V <sub>DDQ</sub>	V <sub>DD</sub>	V <sub>SS</sub>	V <sub>DD</sub>	V <sub>DDQ</sub>	NC	DQ13	DQ4
K	NC	NC	DQ23	V <sub>DDQ</sub>	V <sub>DD</sub>	V <sub>SS</sub>	V <sub>DD</sub>	V <sub>DDQ</sub>	NC	DQ12	DQ3
L	NC	DQ33	DQ24	V <sub>DDQ</sub>	V <sub>SS</sub>	V <sub>SS</sub>	V <sub>SS</sub>	V <sub>DDQ</sub>	NC	NC	DQ2
M	NC	NC	DQ34	V <sub>SS</sub>	V <sub>SS</sub>	V <sub>SS</sub>	V <sub>SS</sub>	V <sub>SS</sub>	NC	DQ11	DQ1
N	NC	DQ35	DQ25	V <sub>SS</sub>	SA	SA	SA	V <sub>SS</sub>	NC	NC	DQ10
P	NC	NC	DQ26	SA	SA	C QVLD QVLD	SA	SA	NC	DQ9	DQ0
R	TDO	TCK	SA	SA	SA	/C NC ODT	SA	SA	SA	TMS	TDI

(Top View)

Top ←R1Q5A7236  
 Mid ←R1QC(J)A7236  
 Bottom ←R1QF(M)A7236

- Notes: 1. Address expansion order for future higher density SRAMs: 10A → 2A → 7A → 5B.  
 2. NC pins can be left floating or connected to 0V ~ V<sub>DDQ</sub>.

R1Q5A7218 (Top) / R1QC(J)A7218 (Mid) / R1QF(M)A7218 (Bottom)

	1	2	3	4	5	6	7	8	9	10	11
A	/CQ	SA	SA	R-/W	/BW1	/K	NC	/LD	SA	SA	CQ
B	NC	DQ9	NC	SA	NC	K	/BW0	SA	NC	NC	DQ8
C	NC	NC	NC	V <sub>SS</sub>	SA	SA0 NC NC	SA1 NC NC	V <sub>SS</sub>	NC	DQ7	NC
D	NC	NC	DQ10	V <sub>SS</sub>	V <sub>SS</sub>	V <sub>SS</sub>	V <sub>SS</sub>	V <sub>SS</sub>	NC	NC	NC
E	NC	NC	DQ11	V <sub>DDQ</sub>	V <sub>SS</sub>	V <sub>SS</sub>	V <sub>SS</sub>	V <sub>DDQ</sub>	NC	NC	DQ6
F	NC	DQ12	NC	V <sub>DDQ</sub>	V <sub>DD</sub>	V <sub>SS</sub>	V <sub>DD</sub>	V <sub>DDQ</sub>	NC	NC	DQ5
G	NC	NC	DQ13	V <sub>DDQ</sub>	V <sub>DD</sub>	V <sub>SS</sub>	V <sub>DD</sub>	V <sub>DDQ</sub>	NC	NC	NC
H	/DOFF	V <sub>REF</sub>	V <sub>DDQ</sub>	V <sub>DDQ</sub>	V <sub>DD</sub>	V <sub>SS</sub>	V <sub>DD</sub>	V <sub>DDQ</sub>	V <sub>DDQ</sub>	V <sub>REF</sub>	ZQ
J	NC	NC	NC	V <sub>DDQ</sub>	V <sub>DD</sub>	V <sub>SS</sub>	V <sub>DD</sub>	V <sub>DDQ</sub>	NC	DQ4	NC
K	NC	NC	DQ14	V <sub>DDQ</sub>	V <sub>DD</sub>	V <sub>SS</sub>	V <sub>DD</sub>	V <sub>DDQ</sub>	NC	NC	DQ3
L	NC	DQ15	NC	V <sub>DDQ</sub>	V <sub>SS</sub>	V <sub>SS</sub>	V <sub>SS</sub>	V <sub>DDQ</sub>	NC	NC	DQ2
M	NC	NC	NC	V <sub>SS</sub>	V <sub>SS</sub>	V <sub>SS</sub>	V <sub>SS</sub>	V <sub>SS</sub>	NC	DQ1	NC
N	NC	NC	DQ16	V <sub>SS</sub>	SA	SA	SA	V <sub>SS</sub>	NC	NC	NC
P	NC	NC	DQ17	SA	SA	C QVLD QVLD	SA	SA	NC	NC	DQ0
R	TDO	TCK	SA	SA	SA	/C NC ODT	SA	SA	SA	TMS	TDI

(Top View)

- Notes: 1. Address expansion order for future higher density SRAMs: 10A → 2A → 7A → 5B.  
 2. NC pins can be left floating or connected to 0V ~ V<sub>DDQ</sub>.

Pin Arrangement

Just Reference

R1Q5A7209 (Top) / R1QC(J)A7209 (Mid) / R1QF(M)A7209 (Bottom)

	1	2	3	4	5	6	7	8	9	10	11
A	/CQ	SA	SA	R-/W	NC	/K	NC	/LD	SA	SA	CQ
B	NC	NC	NC	SA	NC	K	/BW	SA	NC	NC	DQ4
C	NC	NC	NC	V <sub>SS</sub>	SA	NC	SA	V <sub>SS</sub>	NC	NC	NC
D	NC	NC	NC	V <sub>SS</sub>	V <sub>SS</sub>	V <sub>SS</sub>	V <sub>SS</sub>	V <sub>SS</sub>	NC	NC	NC
E	NC	NC	DQ5	V <sub>DDQ</sub>	V <sub>SS</sub>	V <sub>SS</sub>	V <sub>SS</sub>	V <sub>DDQ</sub>	NC	NC	DQ3
F	NC	NC	NC	V <sub>DDQ</sub>	V <sub>DD</sub>	V <sub>SS</sub>	V <sub>DD</sub>	V <sub>DDQ</sub>	NC	NC	NC
G	NC	NC	DQ6	V <sub>DDQ</sub>	V <sub>DD</sub>	V <sub>SS</sub>	V <sub>DD</sub>	V <sub>DDQ</sub>	NC	NC	NC
H	/DOFF	V <sub>REF</sub>	V <sub>DDQ</sub>	V <sub>DDQ</sub>	V <sub>DD</sub>	V <sub>SS</sub>	V <sub>DD</sub>	V <sub>DDQ</sub>	V <sub>DDQ</sub>	V <sub>REF</sub>	ZQ
J	NC	NC	NC	V <sub>DDQ</sub>	V <sub>DD</sub>	V <sub>SS</sub>	V <sub>DD</sub>	V <sub>DDQ</sub>	NC	DQ2	NC
K	NC	NC	NC	V <sub>DDQ</sub>	V <sub>DD</sub>	V <sub>SS</sub>	V <sub>DD</sub>	V <sub>DDQ</sub>	NC	NC	NC
L	NC	DQ7	NC	V <sub>DDQ</sub>	V <sub>SS</sub>	V <sub>SS</sub>	V <sub>SS</sub>	V <sub>DDQ</sub>	NC	NC	DQ1
M	NC	NC	NC	V <sub>SS</sub>	V <sub>SS</sub>	V <sub>SS</sub>	V <sub>SS</sub>	V <sub>SS</sub>	NC	NC	NC
N	NC	NC	NC	V <sub>SS</sub>	SA	SA	SA	V <sub>SS</sub>	NC	NC	NC
P	NC	NC	DQ8	SA	SA	<sup>C</sup> QVLD QVLD	SA	SA	NC	NC	DQ0
R	TDO	TCK	SA	SA	SA	/C NC ODT	SA	SA	SA	TMS	TDI

(Top View)

- Notes: 1. Address expansion order for future higher density SRAMs: 10A → 2A → 7A → 5B.  
 2. NC pins can be left floating or connected to 0V ~ V<sub>DDQ</sub>.  
 3. Note that 6C is not SA0 and 7C is not SA1 in x9 product. Thus x9 product does not permit random start address on the two least significant address bits. SA0, SA1 = 0 at the start of each address.

## Pin Descriptions

Name	I/O type	Descriptions	Notes
SA <sub>x</sub>	Input	Synchronous address inputs: These inputs are registered and must meet the setup and hold times around the rising edge of K. All transactions operate on a burst-of-four words (two clock periods of bus activity). SA0 and SA1 are used as the lowest two address bits for burst READ and burst WRITE operations permitting a random burst start address on ×18 and ×36 of DDR II (not II+) devices. These inputs are ignored when device is deselected or once burst operation is in progress.	
/LD	Input	Synchronous load: This input is brought low when a bus cycle sequence is to be defined. This definition includes address and READ / WRITE direction. All transactions operate on a burst-of-four data (two clock periods of bus activity).	
R-/W	Input	Synchronous read / write Input: When /LD is low, this input designates the access type (READ when R-/W is high, WRITE when R-/W is low) for the loaded address. R-/W must meet the setup and hold times around the rising edge of K.	
/BW <sub>x</sub>	Input	Synchronous byte writes: When low, these inputs cause their respective byte to be registered and written during WRITE cycles. These signals are sampled on the same edge as the corresponding data and must meet setup and hold times around the rising edges of K and /K for each of the two rising edges comprising the WRITE cycle. See Byte Write Truth Table for signal to data relationship.	
K, /K	Input	Input clock: This input clock pair registers address and control inputs on the rising edge of K, and registers data on the rising edge of K and the rising edge of /K. /K is ideally 180 degrees out of phase with K. All synchronous inputs must meet setup and hold times around the clock rising edges. These balls cannot remain V <sub>REF</sub> level.	
C, /C (II only)	Input	Output clock: This clock pair provides a user-controlled means of tuning device output data. The rising edge of /C is used as the output timing reference for the first and third output data. The rising edge of C is used as the output timing reference for second and fourth output data. Ideally, /C is 180 degrees out of phase with C. C and /C may be tied high to force the use of K and /K as the output reference clocks instead of having to provide C and /C clocks. If tied high, C and /C must remain high and not to be toggled during device operation. These balls cannot remain V <sub>REF</sub> level.	1
/DOFF	Input	DLL/PLL disable: When low, this input causes the DLL/PLL to be bypassed for stable, low frequency operation.	
TMS TDI	Input	IEEE1149.1 test inputs: 1.8 V I/O levels. These balls may be left not connected if the JTAG function is not used in the circuit.	
TCK	Input	IEEE1149.1 clock input: 1.8 V I/O levels. This ball must be tied to V <sub>SS</sub> if the JTAG function is not used in the circuit.	
Notes:			
1. R1Q2, R1Q3, R1Q4, R1Q5, R1Q6 series have C and /C pins. R1QA, R1QB, R1QC, R1QD, R1QE, R1QF, R1QG, R1QH, R1QJ, R1QK, R1QL, R1QM, R1QN, R1QP series do not have C, /C pins. In the series, K and /K are used as the output reference clocks instead of C and /C. Therefore, hereafter, C and /C represent K and /K in this document.			

Name	I/O type	Descriptions	Notes
ZQ	Input	Output impedance matching input: This input is used to tune the device outputs to the system data bus impedance. DQ and CQ output impedance are set to $0.2 \times RQ$ , where RQ is a resistor from this ball to ground. This ball can be connected directly to $V_{DDQ}$ , which enables the minimum impedance mode. This ball cannot be connected directly to $V_{SS}$ or left unconnected. In ODT (On Die Termination) enable devices, the ODT termination values tracks the value of RQ. The ODT range is selected by ODT control input.	
ODT (II+ only)	Input	ODT control: <b>When low</b> ; [Option 1] Low range mode is selected. The impedance range is between $52 \Omega$ and $105 \Omega$ (Thevenin equivalent), which follows $0.3 \times RQ$ for $175 \Omega \leq RQ \leq 350 \Omega$ . [Option 2] ODT is disabled. <b>When high</b> ; High range mode is selected. The impedance range is between $105 \Omega$ and $150 \Omega$ (Thevenin equivalent), which follows $0.6 \times RQ$ for $175 \Omega \leq RQ \leq 250 \Omega$ . <b>When floating</b> ; [Option 1] High range mode is selected. [Option 2] ODT is disabled.	1
DQ <sub>0</sub> to DQ <sub>n</sub>	Input / output	Synchronous data I/Os: Input data must meet setup and hold times around the rising edges of K and /K. Output data is synchronized to the respective C and /C, or to the respective K and /K if C and /C are tied high. The $\times 9$ device uses DQ0~DQ8. DQ9~DQ35 should be treated as NC pin. The $\times 18$ device uses DQ0~DQ17. DQ18~DQ35 should be treated as NC pin. The $\times 36$ device uses DQ0~DQ35.	
CQ, /CQ	Output	Synchronous echo clock outputs: The edges of these outputs are tightly matched to the synchronous data outputs and can be used as a data valid indication. These signals run freely and do not stop when DQ tri-states.	
TDO	Output	IEEE 1149.1 test output: 1.8 V I/O level.	
QVLD (II+ only)	Output	Valid output indicator: The Q Valid indicates valid output data. QVLD is edge aligned with CQ and /CQ.	
$V_{DD}$	Supply	Power supply: 1.8 V nominal. See DC Characteristics and Operating Conditions for range.	2
$V_{DDQ}$	Supply	Power supply: Isolated output buffer supply. Nominally 1.5 V. See DC Characteristics and Operating Conditions for range.	2
$V_{SS}$	Supply	Power supply: Ground.	2
$V_{REF}$	—	HSTL input reference voltage: Nominally $V_{DDQ}/2$ , but may be adjusted to improve system noise margin. Provides a reference voltage for the HSTL input buffers.	
NC	—	No connect: These pins can be left floating or connected to $0V \sim V_{DDQ}$ .	
Notes: 1. Renesas status: Option 1 = Available, Option 2 = Possible. 2. All power supply and ground balls must be connected for proper operation of the device.			

**Block Diagram** (R1QxA7236 / R1QxA7218 series, x=5)

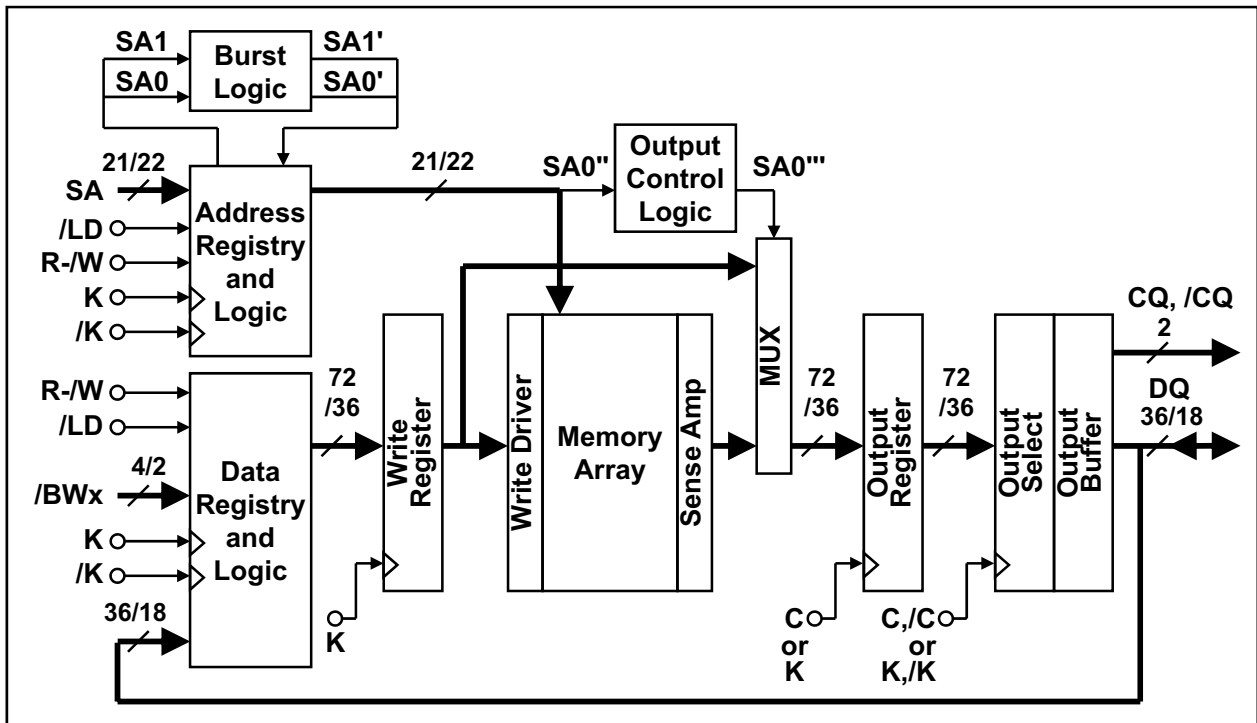

**Notes**

1. C and /C pins do not exist in II+ series parts.

**Block Diagram**

(R1QxA7236 / R1QxA7218 / R1QyA7209 series, x=C,F,J,M, y=5,C,F,J,M)

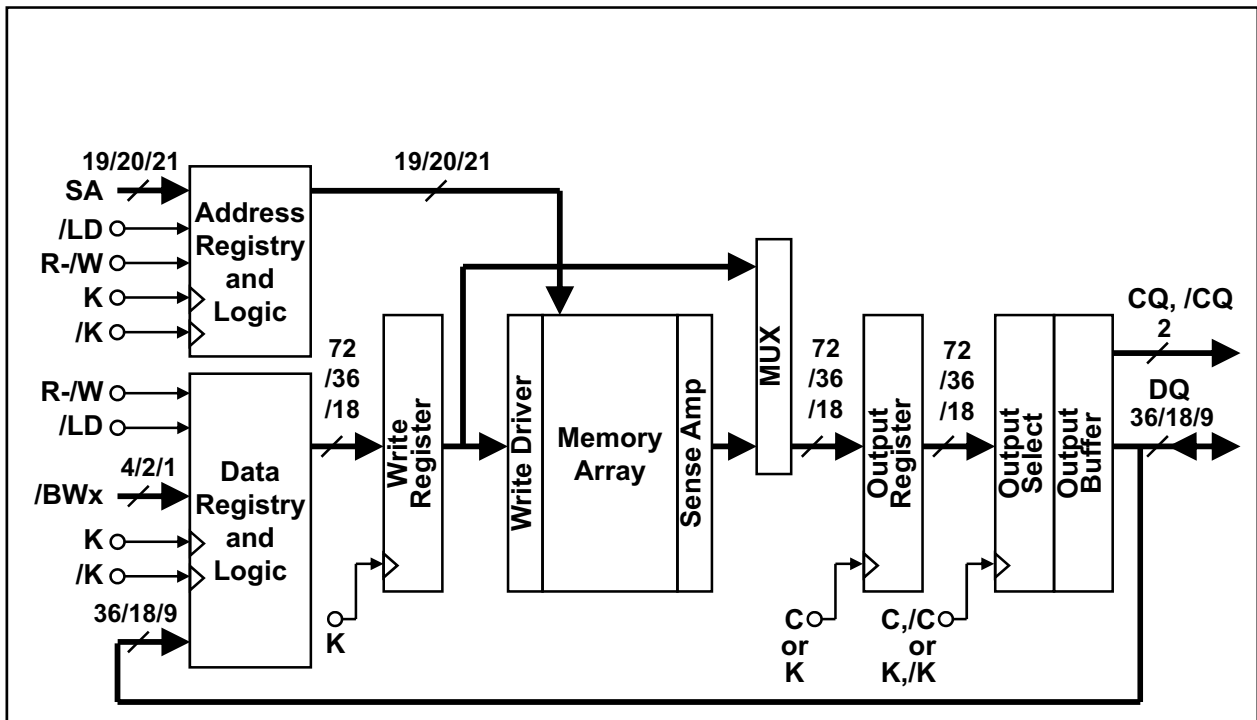

**Notes**

1. C and /C pins do not exist in II+ series parts.

## General Description

### Power-up and Initialization Sequence

- $V_{DD}$  must be stable before K, /K clocks are applied.
- Recommended voltage application sequence :  $V_{SS} \rightarrow V_{DD} \rightarrow V_{DDQ} \& V_{REF} \rightarrow V_{IN}$ . (0 V to  $V_{DD}$ ,  $V_{DDQ} < 200$  ms)
- Apply  $V_{REF}$  after  $V_{DDQ}$  or at the same time as  $V_{DDQ}$ .
- Then execute either one of the following three sequences.

#### 1. Single Clock Mode (C and /C tied high)

- Drive /DOFF high (/DOFF can be tied high from the start).
- Then provide stable clocks (K, /K) for at least 1024 cycles (II series) or 20 us (II+ series). These meet the QDR common specification of 20 us.
- When the operating frequency is less than 180 MHz, 2048 cycles are required (II series).

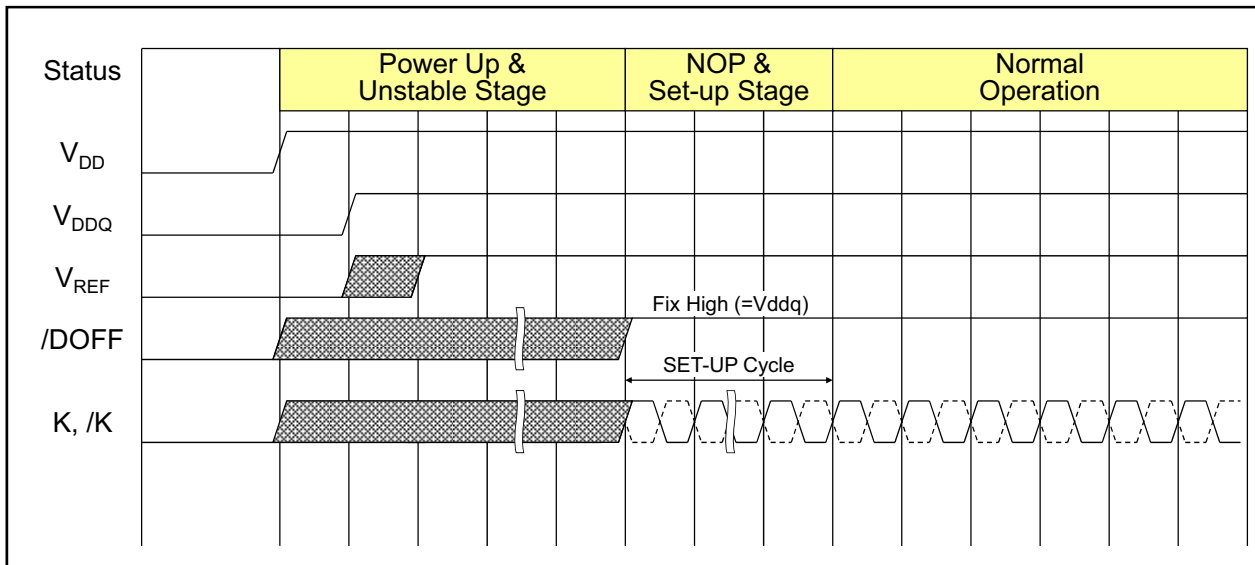

#### 2. Double Clock Mode (C and /C control outputs) (II series only)

- Drive /DOFF high (/DOFF can be tied high from the start)
- Then provide stable clocks (K, /K, C, /C) for at least 1024 cycles (II series). This meets the QDR common specification of 20 us.
- When the operating frequency is less than 180 MHz, 2048 cycles are required (II series).

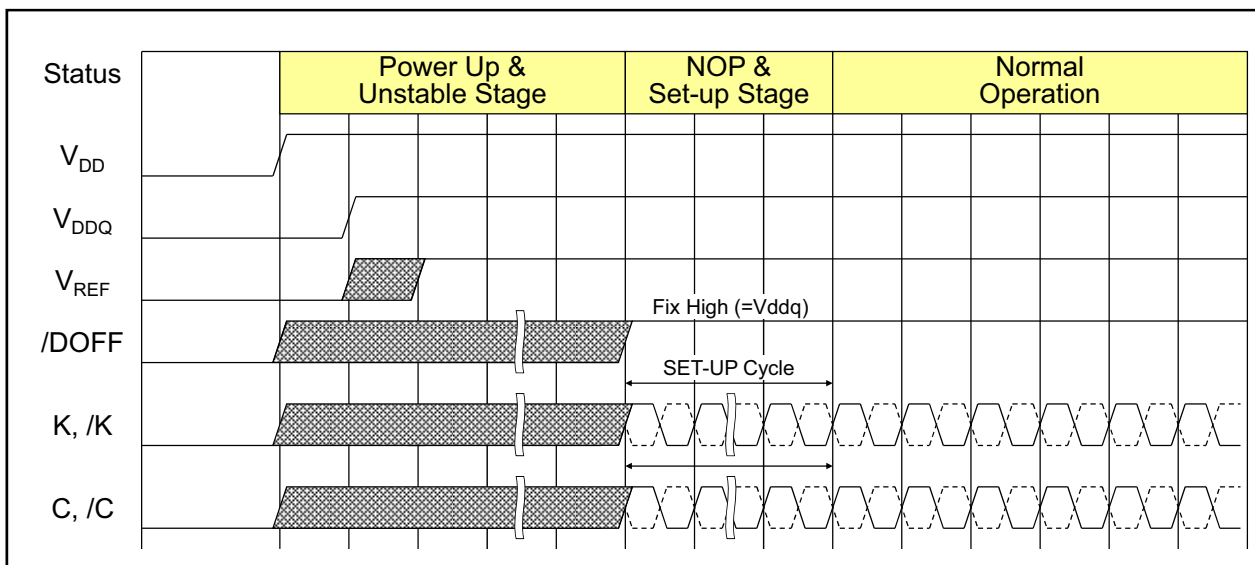

#### 3. DLL/PLL Off Mode (/DOFF tied low)

- In the "NOP and setup stage", provide stable clocks (K, /K) for at least 1024 cycles (II series) or 20 us (II+ series). These meet the QDR common specification of 20 us.

### DLL/PLL Constraints

1. DLL/PLL uses K clock as its synchronizing input. The input should have low phase jitter which is specified as  $t_{KC \text{ var}}$ .
2. The lower end of the frequency at which the DLL/PLL can operate is 120 MHz.  
(Please refer to AC Characteristics table for detail.)
3. When the operating frequency is changed or /DOFF level is changed, setup cycles are required again.

### Programmable Output Impedance

1. Output buffer impedance can be programmed by terminating the ZQ ball to  $V_{SS}$  through a precision resistor (RQ). The value of RQ is five times the output impedance desired. The allowable range of RQ to guarantee impedance matching with a tolerance of 15% is 250  $\Omega$  typical. The total external capacitance of ZQ ball must be less than 7.5 pF.

**QVLD (Valid data indicator)**

(R1QA, R1QB, R1QC, R1QD, R1QE, R1QF, R1QG, R1QH, R1QJ, R1QK, R1QL, R1QM, R1QN, R1QP series)

1. QVLD is provided on the QDR-II+ and DDR-II+ to simplify data capture on high speed systems. The Q Valid indicates valid output data. QVLD is activated half cycle before the read data for the receiver to be ready for capturing the data. QVLD is inactivated half cycle before the read finish for the receiver to stop capturing the data. QVLD is edge aligned with CQ and /CQ.

**ODT (On Die Termination)**

(R1QD, R1QE, R1QF, R1QK, R1QL, R1QM, R1QP series)

1. To reduce reflection which produces noise and lowers signal quality, the signals should be terminated, especially at high frequency. Renesas offers ODT on the input signals to QDR-II+ and DDR-II+ family of devices. (See the ODT pin table)
2. In ODT enable devices, the ODT termination values tracks the value of RQ. The ODT range is selected by ODT control input. (See the ODT range table)
3. In DDR-II+ devices having common I/O bus, ODT is automatically enabled when the device inputs data and disabled when the device outputs data.
4. There is no difference in AC timing characteristics between the SRAMs with ODT and SRAMs without ODT.
5. There is no increase in the  $I_{DD}$  of SRAMs with ODT, however, there is an increase in the  $I_{DDQ}$  (current consumption from the I/O voltage supply) with ODT.

**ODT range**

ODT control pin	Thevenin equivalent resistance ( $R_{THEV}$ )		Unit	Notes
	Option 1	Option 2		
Low	$0.3 \times RQ$	(ODT disable)	$\Omega$	1, 4
High	$0.6 \times RQ$	$0.6 \times RQ$	$\Omega$	2, 5
Floating	$0.6 \times RQ$	(ODT disable)	$\Omega$	3

## Notes:

1. Allowable range of RQ for Option 1 to guarantee impedance matching a tolerance of  $\pm 20\%$  is  $175 \Omega \leq RQ \leq 350 \Omega$ .
2. Allowable range of RQ to guarantee impedance matching a tolerance of  $\pm 20\%$  is  $175 \Omega \leq RQ \leq 250 \Omega$ .
3. Allowable range of RQ for Option 1 to guarantee impedance matching a tolerance of  $\pm 20\%$  is  $175 \Omega \leq RQ \leq 250 \Omega$ .
4. At option 1, ODT control pin is connected to  $V_{DDQ}$  through  $3.5 \text{ k}\Omega$ . Therefore it is recommended to connect it to  $V_{SS}$  through less than  $100 \Omega$  to make it low.
5. At option 2, ODT control pin is connected to  $V_{SS}$  through  $3.5 \text{ k}\Omega$ . Therefore it is recommended to connect it to  $V_{DDQ}$  through less than  $100 \Omega$  to make it high.
6. Renesas status: Option 1 = Available, Option 2 = Possible. If you need devices with option 2, please contact Renesas sales office.

Thevenin termination

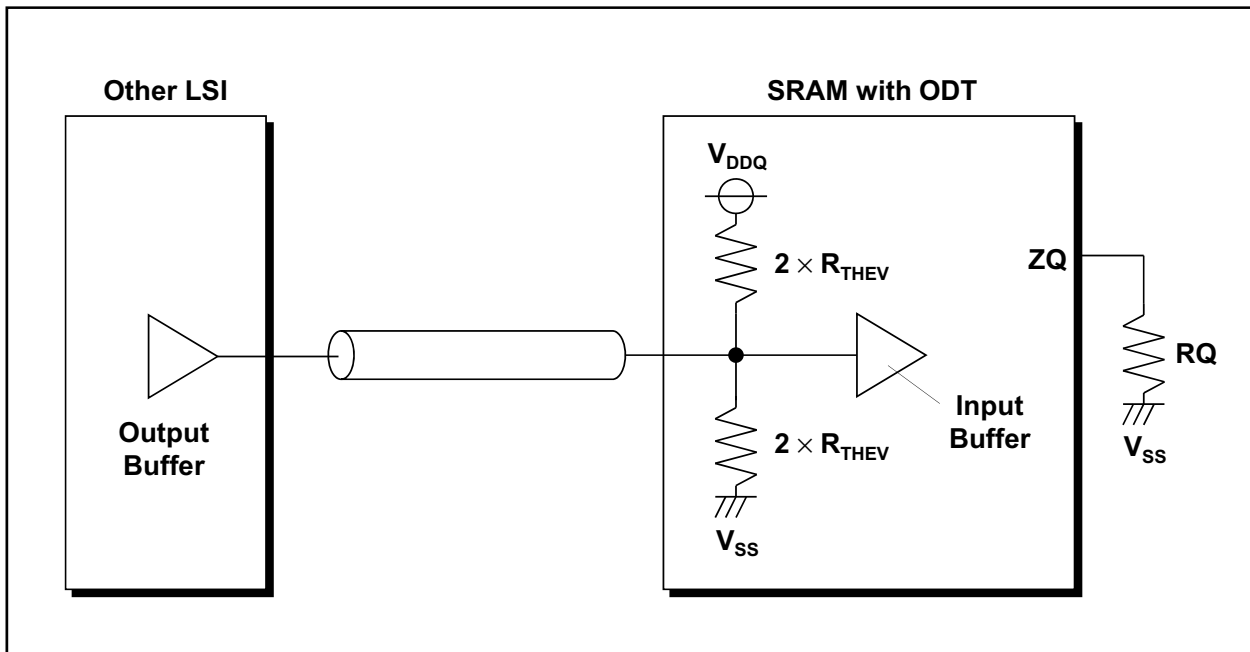

ODT pin (R1QD, R1QE, R1QF, R1QK, R1QL, R1QM, R1QP series)

Pin name	ODT On/Off timing		Notes
	Option 1	Option 2	
		ODT pin = High	
$D_0 \sim D_n$ in separate I/O devices	Always On	Always Off	3
$DQ_0 \sim DQ_n$ in common I/O devices	Off: First Read Command + Read Latency - 0.5 cycle On: Last Read Command + Read Latency + BL/2 cycle + 0.5 cycle (See below timing chart)	Always Off	2
$/BW_x$	Always On	Always Off	
K, /K	Always On	Always Off	

Notes: 1. Separate I/O devices are R1QD, R1QK, R1QP series.  
 2. Common I/O devices are R1QE, R1QF, R1QL, R1QM series.  
 3. Renesas status: Option 1 = Available, Option 2 = Possible. If you need devices with option 2, please contact Renesas sales office.

ODT on/off Timing Chart for R1QE series (DDR II+, Burst Length=2, Read Latency=2.5 cycle)

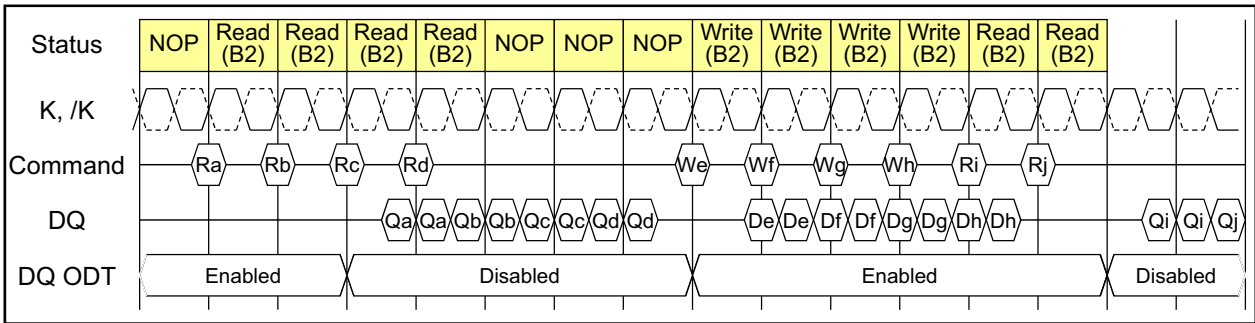

ODT on/off Timing Chart for R1QF series (DDR II+, Burst Length=4, Read Latency=2.5 cycle)

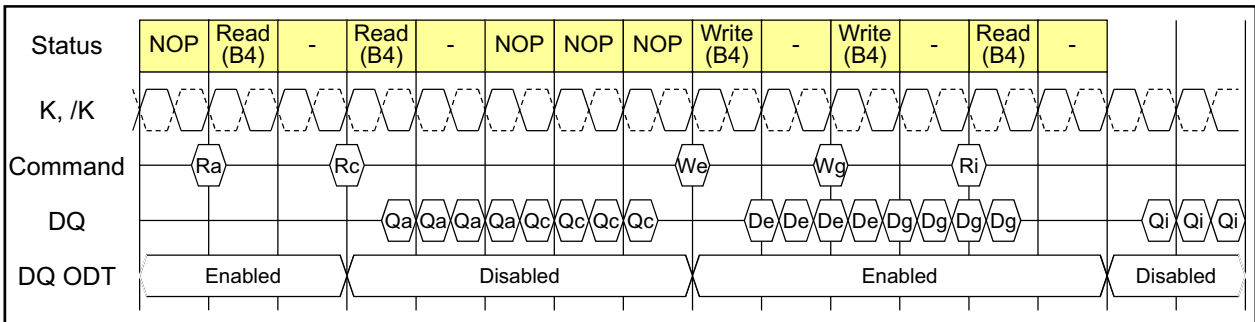

ODT on/off Timing Chart for R1QL series (DDR II+, Burst Length=2, Read Latency=2.0 cycle)

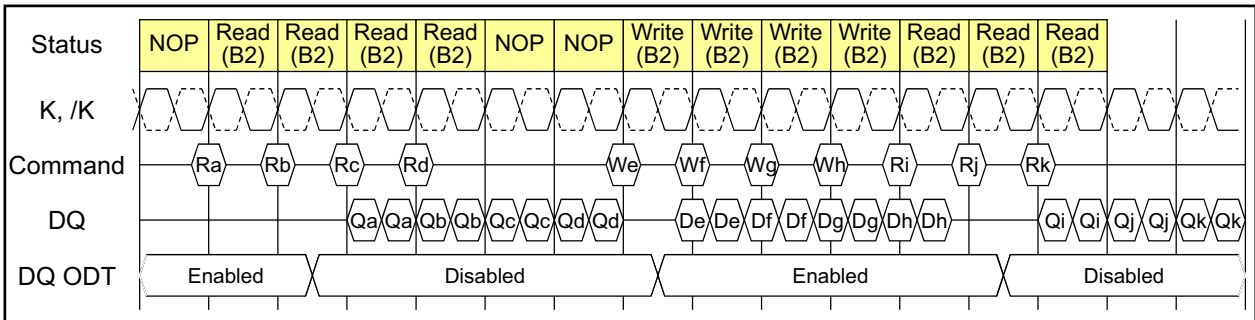

ODT on/off Timing Chart for R1QM series (DDR II+, Burst Length=4, Read Latency=2.0 cycle)

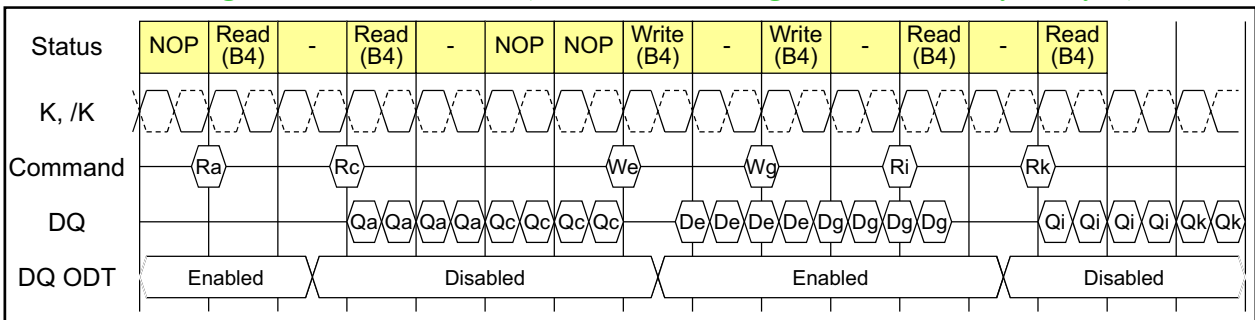

Notes

1. ODT on/off switching timings are edge aligned with CQ or /CQ.

## K Truth Table

Operation	K	/LD	R-/W	DQ					
Write Cycle: Load address, input write data on two consecutive K and /K rising edges	↑	L	L	Data in					
				Input data	D(A1)	D(A2)	D(A3)	D(A4)	
				Input clock	K(t+1)↑	/K(t+1)↑	K(t+2)↑	/K(t+2)↑	
Read Cycle: Load address, output read data on two consecutive C and /C rising edges	↑	L	H	Data out					
				Output data	Q(A1)	Q(A2)	Q(A3)	Q(A4)	
				Input clock for Q	RL <sup>*8</sup> =1.5	/C(t+1)↑	C(t+2)↑	/C(t+2)↑	C(t+3)↑
					RL=2.0	C(t+2)↑	/C(t+2)↑	C(t+3)↑	/C(t+3)↑
RL=2.5	/C(t+2)↑	C(t+3)↑	/C(t+3)↑		C(t+4)↑				
NOP (No operation)	↑	H	×	High-Z					
Standby (Clock stopped)	Stopped	×	×	Previous state					

Notes:

- H: high level, L: low level, ×: don't care, ↑: rising edge.
- Data inputs are registered at K and /K rising edges. Data outputs are delivered at C and /C rising edges, except if C and /C are high, then data outputs are delivered at K and /K rising edges.
- /LD and R-/W must meet setup/hold times around the rising edges (low to high) of K and are registered at the rising edge of K.
- This device contains circuitry that will ensure the outputs will be in high-Z during power-up.
- Refer to state diagram and timing diagrams for clarification.
- When clocks are stopped, the following cases are recommended; the case of K = low, /K = high, C = low and /C = high, or the case of K = high, /K = low, C = high and /C = low. This condition is not essential, but permits most rapid restart by overcoming transmission line charging symmetrically.
- A1 refers to the address input during a WRITE or READ cycle. A2, A3 and A4 refer to the 1st, 2nd and 3rd internal burst address, respectively, in accordance with the linear burst sequence.
- RL = Read Latency (unit = cycle).

## Burst Sequence

Linear Burst Sequence Table (R1Q5Aww36 / R1Q5Aww18 series )

	SA1, SA0	SA1, SA0	SA1, SA0	SA1, SA0	Notes
External address	0, 0	0, 1	1, 0	1, 1	
1st internal burst address	0, 1	1, 0	1, 1	0, 0	
2nd internal burst address	1, 0	1, 1	0, 0	0, 1	
3rd internal burst address	1, 1	0, 0	0, 1	1, 0	

## Byte Write Truth Table ( x 36 )

Operation	K	/K	/BW0	/BW1	/BW2	/BW3
Write D0 to D35	↑	-	L	L	L	L
	-	↑	L	L	L	L
Write D0 to D8	↑	-	L	H	H	H
	-	↑	L	H	H	H
Write D9 to D17	↑	-	H	L	H	H
	-	↑	H	L	H	H
Write D18 to D26	↑	-	H	H	L	H
	-	↑	H	H	L	H
Write D27 to D35	↑	-	H	H	H	L
	-	↑	H	H	H	L
Write nothing	↑	-	H	H	H	H
	-	↑	H	H	H	H

Notes:

1. H: high level, L: low level, ↑: rising edge.
2. Assumes a WRITE cycle was initiated. /BWx can be altered for any portion of the BURST WRITE operation provided that the setup and hold requirements are satisfied.

## Byte Write Truth Table ( x 18 )

Operation	K	/K	/BW0	/BW1
Write D0 to D17	↑	-	L	L
	-	↑	L	L
Write D0 to D8	↑	-	L	H
	-	↑	L	H
Write D9 to D17	↑	-	H	L
	-	↑	H	L
Write nothing	↑	-	H	H
	-	↑	H	H

Notes:

1. H: high level, L: low level, ↑: rising edge.
2. Assumes a WRITE cycle was initiated. /BWx can be altered for any portion of the BURST WRITE operation provided that the setup and hold requirements are satisfied.

Byte Write Truth Table ( x 9 ) Just Reference except R1Q2A\*\*09 series

Operation	K	/K	/BW
Write D0 to D8	↑	-	L
	-	↑	L
Write nothing	↑	-	H
	-	↑	H

Notes:

1. H: high level, L: low level, ↑: rising edge.
2. Assumes a WRITE cycle was initiated. /BWx can be altered for any portion of the BURST WRITE operation provided that the setup and hold requirements are satisfied.

**Bus Cycle State Diagram**

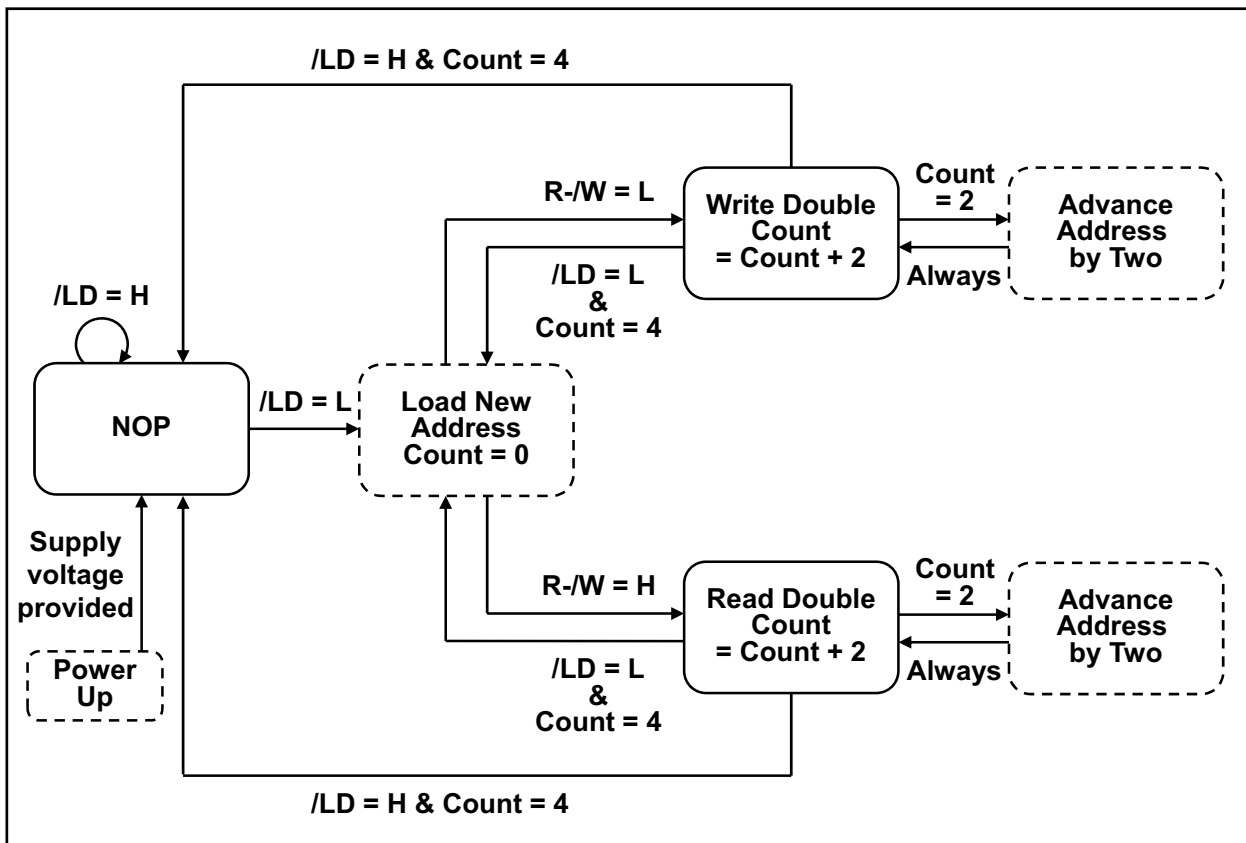

Notes:

1. SA0 and SA1 are internally advanced in accordance with the burst order table. Bus cycle is terminated at the end of this sequence (burst count = 4).
2. State machine control timing sequence is controlled by K.

## Absolute Maximum Ratings

Parameter	Symbol	Rating	Unit	Notes
Input voltage on any ball	$V_{IN}$	-0.5 to $V_{DD} + 0.5$ (2.5 V max.)	V	1, 4
Input/output voltage	$V_{I/O}$	-0.5 to $V_{DDQ} + 0.5$ (2.5 V max.)	V	1, 4
Core supply voltage	$V_{DD}$	-0.5 to 2.5	V	1, 4
Output supply voltage	$V_{DDQ}$	-0.5 to $V_{DD}$	V	1, 4
Junction temperature	$T_j$	+125 (max)	°C	5
Storage temperature	$T_{STG}$	-55 to +125	°C	

### Notes:

- All voltage is referenced to  $V_{SS}$ .
- Permanent device damage may occur if Absolute Maximum Ratings are exceeded. Functional operation should be restricted the Operation Conditions. Exposure to higher than recommended voltages for extended periods of time could affect device reliability.
- These CMOS memory circuits have been designed to meet the DC and AC specifications shown in the tables after thermal equilibrium has been established.
- The following supply voltage application sequence is recommended:  $V_{SS}$ ,  $V_{DD}$ ,  $V_{DDQ}$ ,  $V_{REF}$  then  $V_{IN}$ . Remember, according to the Absolute Maximum Ratings table,  $V_{DDQ}$  is not to exceed 2.5 V, whatever the instantaneous value of  $V_{DDQ}$ .
- Some method of cooling or airflow should be considered in the system. (Especially for high frequency or ODT parts)

## Recommended DC Operating Conditions

Parameter	Symbol	Min	Typ	Max	Unit	Notes
Power supply voltage -- core	$V_{DD}$	1.7	1.8	1.9	V	1
Power supply voltage -- I/O	$V_{DDQ}$	1.4	1.5	$V_{DD}$	V	1, 2
Input reference voltage -- I/O	$V_{REF}$	0.68	0.75	0.95	V	3
Input high voltage	$V_{IH(DC)}$	$V_{REF} + 0.1$	—	$V_{DDQ} + 0.3$	V	1, 4, 5
Input low voltage	$V_{IL(DC)}$	-0.3	—	$V_{REF} - 0.1$	V	1, 4, 5

### Notes:

- At power-up,  $V_{DD}$  and  $V_{DDQ}$  are assumed to be a linear ramp from 0V to  $V_{DD}$  (min.) or  $V_{DDQ}$  (min.) within 200ms. During this time  $V_{DDQ} < V_{DD}$  and  $V_{IH} < V_{DDQ}$ . During normal operation,  $V_{DDQ}$  must not exceed  $V_{DD}$ .
- Please pay attention to  $T_j$  not to exceed the temperature shown in the absolute maximum ratings table due to current from  $V_{DDQ}$ .
- Peak to peak AC component superimposed on  $V_{REF}$  may not exceed 5% of  $V_{REF}$ .
- These are DC test criteria. The AC  $V_{IH}$  /  $V_{IL}$  levels are defined separately to measure timing parameters.
- Overshoot:  $V_{IH(AC)} \leq V_{DDQ} + 0.5$  V for  $t \leq t_{KHKH}/2$   
Undershoot:  $V_{IL(AC)} \geq -0.5$  V for  $t \leq t_{KHKH}/2$   
During normal operation,  $V_{IH(DC)}$  must not exceed  $V_{DDQ}$  and  $V_{IL(DC)}$  must not be lower than  $V_{SS}$ .

DC Characteristics

(Ta = 0 ~ +70°C @ R1Q\*A\*\*\*\*\*BB-\*\*R\*\* series, Ta = -40 ~ +85°C @ R1Q\*A\*\*\*\*\*BB-\*\*I\*\* series)  
 (V<sub>DD</sub> = 1.8V ±0.1V, V<sub>DDQ</sub> = 1.5V, V<sub>REF</sub> = 0.75V)

Operating Supply Current (Write / Read)

Symbol = I<sub>DD</sub>. Unit = mA. See Notes 1, 2 and 3 in the page after next.

No	Product Type	Burst Length	Latency (Cycle)	ODT	Organi- zation	Frequency (max) (MHz)	QDR II+ / DDR II+						QDR II / DDR II						
							533	500	450	400	375	333	333	300	250	200			
							Cycle Time (min) (ns)		1.875	2.00	2.22	2.50	2.66	3.00	3.00	3.30	4.00	5.00	
						Part Number ↓	yy →	-19	-20	-22	-25	-27	-30	-30	-33	-40	-50		
1	QDRII	B2	1.5	No	x 9	R1Q 2 A72 09 ABv-yy										760	670		
2					x18	R1Q 2 A72 18 ABv-yy												890	780
3					x36	R1Q 2 A72 36 ABv-yy												950	830
5	B4	x18			R1Q 3 A72 18 ABv-yy								880	820	730				
6		x36			R1Q 3 A72 36 ABv-yy								910	850	750				
8		x18			R1Q 4 A72 18 ABv-yy								750	700	630				
9	DDRII	B2	x36	R1Q 4 A72 36 ABv-yy							810	760	680						
11			B4	x18	R1Q 5 A72 18 ABv-yy							660	630	590					
12				x36	R1Q 5 A72 36 ABv-yy								700	670	630				
14	DDRII SIO	B2	x18	R1Q 6 A72 18 ABv-yy							750	700	630						
15			x36	R1Q 6 A72 36 ABv-yy								810	760	680					
17	QDRII+	B4	2.5	No	x18	R1Q A A72 18 ABv-yy	1220	1160	1070										
18					x36	R1Q A A72 36 ABv-yy	1280	1220	1130										
20	DDRII+	B2			x18	R1Q B A72 18 ABv-yy	1030	990	920										
21					x36	R1Q B A72 36 ABv-yy	1110	1060	990										
23		B4			x18	R1Q C A72 18 ABv-yy	820	790	750										
24					x36	R1Q C A72 36 ABv-yy	880	850	800										
26	QDRII+	B4	x18	R1Q D A72 18 ABv-yy	1220	1160	1070												
27			x36	R1Q D A72 36 ABv-yy	1280	1220	1130												
29	DDRII+	B2	x18	R1Q E A72 18 ABv-yy	1030	990	920												
30			x36	R1Q E A72 36 ABv-yy	1110	1060	990												
32		B4	x18	R1Q F A72 18 ABv-yy	820	790	750												
33			x36	R1Q F A72 36 ABv-yy	880	850	800												
35	QDRII+	B4	x18	R1Q G A72 18 ABv-yy				980											
36			x36	R1Q G A72 36 ABv-yy				1060											
38	DDRII+	B2	x18	R1Q H A72 18 ABv-yy				850											
39			x36	R1Q H A72 36 ABv-yy				910											
41		B4	x18	R1Q J A72 18 ABv-yy				710											
42			x36	R1Q J A72 36 ABv-yy				760											
44	QDRII+	B4	x18	R1Q K A72 18 ABv-yy				980											
45			x36	R1Q K A72 36 ABv-yy				1060											
47	DDRII+	B2	x18	R1Q L A72 18 ABv-yy				850											
48			x36	R1Q L A72 36 ABv-yy				910											
50		B4	x18	R1Q M A72 18 ABv-yy				710											
51			x36	R1Q M A72 36 ABv-yy				760											

Notes:

- "v" represents the package size. If "v" = "G" then size is 15 x 17 mm, and if "v" = "B" then 13 x 15 mm.
- "yy" represents the speed bin. "R1QAA7236ABB-20" can operate at 500 MHz(max) of frequency, for example.

Standby Supply Current (NOP)

Symbol =  $I_{SB1}$ . Unit = mA. See Notes 2, 4 and 5 in the next page.

No	Product Type	Burst Length	Latency (Cycle)	ODT	Organi- zation	Frequency (max) (MHz)	QDR II+ / DDR II+						QDR II / DDR II			
							Cycle Time (min) (ns)						333	300	250	200
							533	500	450	400	375	333	333	3.00	4.00	5.00
Part Number ↓		yy →		-19	-20	-22	-25	-27	-30	-30	-33	-40	-50			
1	QDRII	B2	1.5	No	x 9	R1Q 2 A72 09 ABv-yy							570	510		
2					x18	R1Q 2 A72 18 ABv-yy								670	600	
3					x36	R1Q 2 A72 36 ABv-yy								710	630	
5	B4	x18			R1Q 3 A72 18 ABv-yy						630	590	520			
6		x36			R1Q 3 A72 36 ABv-yy						650	610	540			
8		x18			R1Q 4 A72 18 ABv-yy						650	610	560			
9	DDRII	B2	x36	R1Q 4 A72 36 ABv-yy						710	670	610				
11			B4	x18	R1Q 5 A72 18 ABv-yy						540	510	480			
12				x36	R1Q 5 A72 36 ABv-yy						570	540	500			
14	DDRII SIO	B2	x18	R1Q 6 A72 18 ABv-yy						650	610	560				
15			x36	R1Q 6 A72 36 ABv-yy						710	670	610				
17	QDRII+	B4	2.5	No	x18	R1Q A A72 18 ABv-yy	870	830	780							
18					x36	R1Q A A72 36 ABv-yy	910	870	810							
20	DDRII+	B2			x18	R1Q B A72 18 ABv-yy	870	840	780							
21					x36	R1Q B A72 36 ABv-yy	960	920	860							
23		B4			x18	R1Q C A72 18 ABv-yy	690	660	630							
24					x36	R1Q C A72 36 ABv-yy	730	710	670							
26	QDRII+	B4	x18	R1Q D A72 18 ABv-yy	870	830	780									
27			x36	R1Q D A72 36 ABv-yy	910	870	810									
29	DDRII+	B2	x18	R1Q E A72 18 ABv-yy	870	840	780									
30			x36	R1Q E A72 36 ABv-yy	960	920	860									
32		B4	x18	R1Q F A72 18 ABv-yy	690	660	630									
33			x36	R1Q F A72 36 ABv-yy	730	710	670									
35	QDRII+	B4	x18	R1Q G A72 18 ABv-yy			720									
36			x36	R1Q G A72 36 ABv-yy			770									
38	DDRII+	B2	x18	R1Q H A72 18 ABv-yy			720									
39			x36	R1Q H A72 36 ABv-yy			790									
41		B4	x18	R1Q J A72 18 ABv-yy			590									
42			x36	R1Q J A72 36 ABv-yy			630									
44	QDRII+	B4	x18	R1Q K A72 18 ABv-yy			720									
45			x36	R1Q K A72 36 ABv-yy			770									
47	DDRII+	B2	x18	R1Q L A72 18 ABv-yy			720									
48			x36	R1Q L A72 36 ABv-yy			790									
50		B4	x18	R1Q M A72 18 ABv-yy			590									
51			x36	R1Q M A72 36 ABv-yy			630									

Notes:

- "v" represents the package size. If "v" = "G" then size is 15 x 17 mm, and if "v" = "B" then 13 x 15 mm.
- "yy" represents the speed bin. "R1QAA7236ABB-20" can operate at 500 MHz(max) of frequency, for example.

## Leakage Currents &amp; Output Voltage

Parameter	Symbol	Min	Max	Unit	Test condition	Notes
Input leakage current	$I_{LI}$	-2	2	$\mu\text{A}$		10
Output leakage current	$I_{LO}$	-5	5	$\mu\text{A}$		11
Output high voltage	$V_{OH}$ (Low)	$V_{DDQ} - 0.2$	$V_{DDQ}$	V	$ I_{OH}  \leq 0.1 \text{ mA}$	8, 9
	$V_{OH}$	$V_{DDQ}/2 - 0.12$	$V_{DDQ}/2 + 0.12$	V	Note 6	8, 9
Output low voltage	$V_{OL}$ (Low)	$V_{SS}$	0.2	V	$I_{OL} \leq 0.1 \text{ mA}$	8, 9
	$V_{OL}$	$V_{DDQ}/2 - 0.12$	$V_{DDQ}/2 + 0.12$	V	Note 7	8, 9

## Notes:

- All inputs (except ZQ,  $V_{REF}$ ) are held at either  $V_{IH}$  or  $V_{IL}$ .
- $I_{OUT} = 0 \text{ mA}$ .  $V_{DD} = V_{DD} \text{ max}$ ,  $t_{KHKH} = t_{KHKH} \text{ min}$ .
- Operating supply currents ( $I_{DD}$ ) are measured at 100% bus utilization.  $I_{DD}$  of QDR family is current of device with 100% write and 100% read cycle.  $I_{DD}$  of DDR family is current of device with 100% write cycle (if  $I_{DD}(\text{Write}) > I_{DD}(\text{Read})$ ) or 100% read cycle (if  $I_{DD}(\text{Write}) < I_{DD}(\text{Read})$ ).
- All address / data inputs are static at either  $V_{IN} > V_{IH}$  or  $V_{IN} < V_{IL}$ .
- Reference value. (Condition = NOP currents are valid when entering NOP after all pending READ and WRITE cycles are completed. )
- Outputs are impedance-controlled.  $|I_{OH}| = (V_{DDQ}/2)/(RQ/5)$  for values of  $175 \Omega \leq RQ \leq 350 \Omega$ .
- Outputs are impedance-controlled.  $I_{OL} = (V_{DDQ}/2)/(RQ/5)$  for values of  $175 \Omega \leq RQ \leq 350 \Omega$ .
- AC load current is higher than the shown DC values. AC I/O curves are available upon request.
- HSTL outputs meet JEDEC HSTL Class I and Class II standards.
- $0 \leq V_{IN} \leq V_{DDQ}$  for all input balls (except  $V_{REF}$ , ZQ, TCK, TMS, TDI ball).  
If R1QD, R1QE, R1QF, R1QK, R1QL, R1QM, R1QP series, balls with ODT do not follow this spec.
- $0 \leq V_{OUT} \leq V_{DDQ}$  (except TDO ball), output disabled.

### Thermal Resistance

Parameter	Symbol	Airflow	Typ	Unit	Test condition	Notes
Junction to Ambient	$\theta_{JA}$	1 m/s	11.0	°C/W	EIA/JEDEC JESD51	1
Junction to Case	$\theta_{JC}$	-	4.4			

Notes:

- These parameters are calculated under the condition. These are reference values.
- $T_j = T_a + \theta_{JA} \times P_d$   
 $T_j = T_c + \theta_{JC} \times P_d$   
 where  
 $T_j$ : junction temperature when the device has achieved a steady-state after application of  $P_d$  (°C)  
 $T_a$ : ambient temperature (°C)  
 $T_c$ : temperature of external surface of the package or case (°C)  
 $\theta_{JA}$ : thermal resistance from junction-to-ambient (°C/W)  
 $\theta_{JC}$ : thermal resistance from junction-to-case (package) (°C/W)  
 $P_d$ : power dissipation that produced change in junction temperature (W) (cf.JESD51-2A)

### Capacitance

( $T_a = +25^\circ\text{C}$ , Frequency = 1.0MHz,  $V_{DD} = 1.8\text{V}$ ,  $V_{DDQ} = 1.5\text{V}$ )

Parameter	Symbol	Min	Typ	Max	Unit	Test condition	Notes
Input capacitance (SA, /R, /W, /BW, D(separate))	$C_{IN}$	—	4	5	pF	$V_{IN} = 0\text{V}$	1, 2
Clock input capacitance (K, /K, C, /C)	$C_{CLK}$	—	4	5	pF	$V_{CLK} = 0\text{V}$	1, 2
Output capacitance (Q(separate), DQ(common), CQ, /CQ)	$C_{I/O}$	—	5	6	pF	$V_{I/O} = 0\text{V}$	1, 2

Notes:

- These parameters are sampled and not 100% tested.
- Except JTAG (TCK, TMS, TDI, TDO) pins.

### AC Test Conditions

Input waveform (Rise/fall time  $\leq 0.3\text{ ns}$ )

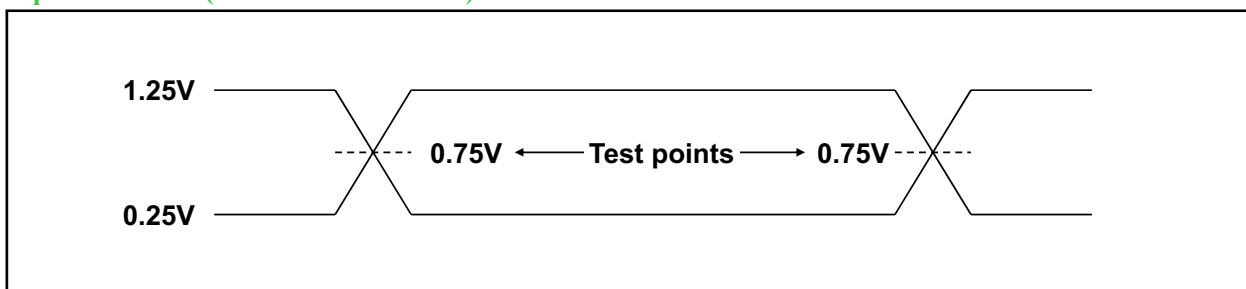

Output waveform

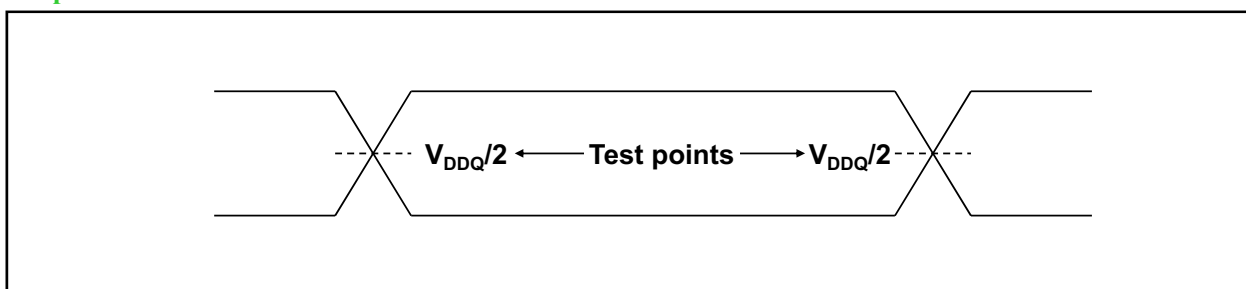

Output load conditions

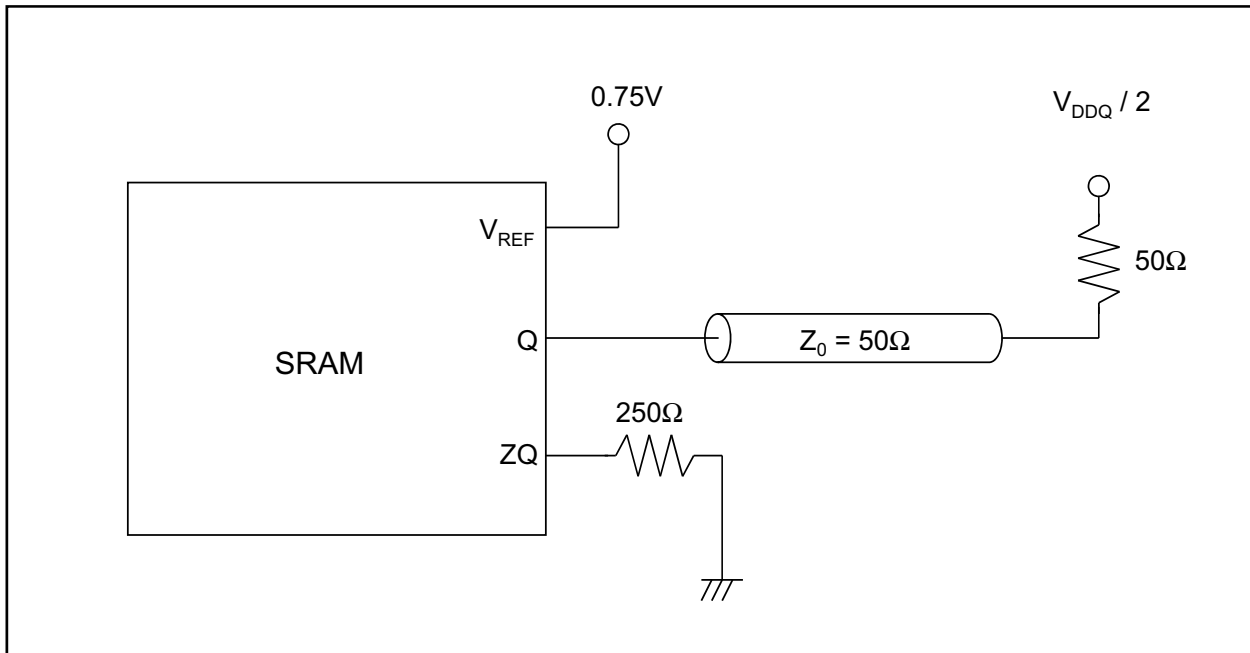

AC Operating Conditions

Parameter	Symbol	Min	Typ	Max	Unit	Notes
Input high voltage	$V_{IH(AC)}$	$V_{REF} + 0.2$	—	—	V	1, 2, 3, 4
Input low voltage	$V_{IL(AC)}$	—	—	$V_{REF} - 0.2$	V	1, 2, 3, 4

Notes:

1. All voltages referenced to  $V_{SS}$  (GND).  
During normal operation,  $V_{DDQ}$  must not exceed  $V_{DD}$ .
2. These conditions are for AC functions only, not for AC parameter test.
3. Overshoot:  $V_{IH(AC)} \leq V_{DDQ} + 0.5\text{ V}$  for  $t \leq t_{KHKH}/2$   
Undershoot:  $V_{IL(AC)} \geq -0.5\text{ V}$  for  $t \leq t_{KHKH}/2$   
Control input signals may not have pulse widths less than  $t_{KHKL}$  (min) or operate at cycle rates less than  $t_{KHKL}$  (min).
4. To maintain a valid level, the transitioning edge of the input must:
  - a. Sustain a constant slew rate from the current AC level through the target AC level,  $V_{IL(AC)}$  or  $V_{IH(AC)}$ .
  - b. Reach at least the target AC level.
  - c. After the AC target level is reached, continue to maintain at least the target DC level,  $V_{IL(DC)}$  or  $V_{IH(DC)}$ .

**AC Characteristics (Read Latency = 2.5 cycle)**

(Ta = 0 ~ +70°C @ R1Q\*A\*\*\*\*\*BB\*\*R\*\* series)

(Ta = -40 ~ +85°C @ R1Q\*A\*\*\*\*\*BB-\*\*I\*\* series)

(V<sub>DD</sub> = 1.8V ±0.1V, V<sub>DDQ</sub> = 1.5V, V<sub>REF</sub> = 0.75V)

Parameter	Symbol	-19		-20		-22		-25		-27		-30		Unit	Notes
		Min	Max	Min	Max	Min	Max	Min	Max	Min	Max	Min	Max		
Clock															
Average clock cycle time (K, /K)	t <sub>KHKH</sub>	1.875	4.00	2.00	4.00	2.22	4.00	2.50	4.00	2.66	4.00	3.00	4.00	ns	
Clock high time (K, /K)	t <sub>KHKL</sub>	0.40	—	0.40	—	0.40	—	0.40	—	0.40	—	0.40	—	Cycle	
Clock low time (K, /K)	t <sub>KLKH</sub>	0.40	—	0.40	—	0.40	—	0.40	—	0.40	—	0.40	—	Cycle	
Clock to /clock (K to /K)	t <sub>KH/KH</sub>	0.425	—	0.425	—	0.425	—	0.425	—	0.425	—	0.425	—	Cycle	
/Clock to clock (/K to K)	t <sub>/KHKH</sub>	0.425	—	0.425	—	0.425	—	0.425	—	0.425	—	0.425	—	Cycle	
—	—	—	—	—	—	—	—	—	—	—	—	—	—	—	—
DLL/PLL Timing															
Clock phase jitter (K, /K)	t <sub>KC var</sub>	—	0.15	—	0.15	—	0.15	—	0.20	—	0.20	—	0.20	ns	3
Lock time (K)	t <sub>KC lock</sub>	20	—	20	—	20	—	20	—	20	—	20	—	us	2
K static to DLL/PLL reset	t <sub>KC reset</sub>	30	—	30	—	30	—	30	—	30	—	30	—	ns	7
Output Times															
K, /K high to output valid	t <sub>CHQV</sub>	—	0.45	—	0.45	—	0.45	—	0.45	—	0.45	—	0.45	ns	
K, /K high to output hold	t <sub>CHQX</sub>	-0.45	—	-0.45	—	-0.45	—	-0.45	—	-0.45	—	-0.45	—	ns	
K, /K high to echo clock valid	t <sub>CHCQV</sub>	—	0.45	—	0.45	—	0.45	—	0.45	—	0.45	—	0.45	ns	
K, /K high to echo clock hold	t <sub>CHCQX</sub>	-0.45	—	-0.45	—	-0.45	—	-0.45	—	-0.45	—	-0.45	—	ns	
CQ, /CQ high to output valid	t <sub>CQHQV</sub>	—	0.15	—	0.15	—	0.15	—	0.20	—	0.20	—	0.20	ns	4, 7
CQ, /CQ high to output hold	t <sub>CQHQX</sub>	-0.15	—	-0.15	—	-0.15	—	-0.20	—	-0.20	—	-0.20	—	ns	4, 7
K, /K high to output high-Z	t <sub>CHQZ</sub>	—	0.45	—	0.45	—	0.45	—	0.45	—	0.45	—	0.45	ns	5, 6
K, /K high to output low-Z	t <sub>CHQX1</sub>	-0.45	—	-0.45	—	-0.45	—	-0.45	—	-0.45	—	-0.45	—	ns	5
CQ high to QVLD valid	t <sub>QVLD</sub>	-0.15	0.15	-0.15	0.15	-0.15	0.15	-0.20	0.20	-0.20	0.20	-0.20	0.20	ns	7

Parameter	Symbol	-19		-20		-22		-25		-27		-30		Unit	Notes
		Min	Max	Min	Max	Min	Max	Min	Max	Min	Max	Min	Max		
Setup Times															
Address valid to K rising edge	$t_{AVKH}$ (QDRII+ B2)	—	—	—	—	—	—	—	—	—	—	—	—	ns	1, 8
	$t_{AVKH}$ (QDRII+ B4 & DDRII+)	0.30	—	0.33	—	0.40	—	0.40	—	0.40	—	0.40	—		
Control inputs valid to K rising edge	$t_{IVKH}$ (QDRII+ B2)	—	—	—	—	—	—	—	—	—	—	—	ns	1, 8	
	$t_{IVKH}$ (QDRII+ B4 & DDRII+)	0.30	—	0.33	—	0.40	—	0.40	—	0.40	—	0.40			—
Data-in valid to K, /K rising edge	$t_{DVKH}$	0.20	—	0.22	—	0.25	—	0.28	—	0.28	—	0.28	—	ns	1, 9
Hold Times															
K rising edge to address hold	$t_{KHAX}$ (QDRII+ B2)	—	—	—	—	—	—	—	—	—	—	—	ns	1, 8	
	$t_{KHAX}$ (QDRII+ B4 & DDRII+)	0.30	—	0.33	—	0.40	—	0.40	—	0.40	—	0.40			—
K rising edge to control inputs hold	$t_{KHIX}$ (QDRII+ B2)	—	—	—	—	—	—	—	—	—	—	—	ns	1, 8	
	$t_{KHIX}$ (QDRII+ B4 & DDRII+)	0.30	—	0.33	—	0.40	—	0.40	—	0.40	—	0.40			—
K, /K rising edge to data-in hold	$t_{KHDX}$	0.20	—	0.22	—	0.25	—	0.28	—	0.28	—	0.28	—	ns	1, 9

Notes:

1. This is a synchronous device. All addresses, data and control lines must meet the specified setup and hold times for all latching clock edges.
2.  $V_{DD}$  and  $V_{DDQ}$  slew rate must be less than 0.1 V DC per 50 ns for DLL/PLL lock retention. DLL/PLL lock time begins once  $V_{DD}$ ,  $V_{DDQ}$  and input clock are stable. It is recommended that the device is kept inactive during these cycles. This specification meets the QDR common spec. of 20 us.
3. Clock phase jitter is the variance from clock rising edge to the next expected clock rising edge.
4. Echo clock is very tightly controlled to data valid / data hold. By design, there is a  $\pm 0.1$  ns variation from echo clock to data. The datasheet parameters reflect tester guardbands and test setup variations.
5. Transitions are measured  $\pm 100$  mV from steady-state voltage.
6. At any given voltage and temperature  $t_{CHQZ}$  is less than  $t_{CHQX1}$  and  $t_{CHQV}$ .
7. These parameters are sampled.
8.  $t_{AVKH}$ ,  $t_{IVKH}$ ,  $t_{KHAX}$ ,  $t_{KHIX}$  spec is determined by the actual frequency regardless of Part Number (Marking Name). The following is the spec for the actual frequency.  
 0.30 ns for  $\leq 533\text{MHz}$  &  $> 500\text{MHz}$   
 0.33 ns for  $\leq 500\text{MHz}$  &  $> 450\text{MHz}$   
 0.40 ns for  $\leq 450\text{MHz}$  &  $\geq 250\text{MHz}$
9.  $t_{DVKH}$ ,  $t_{KHDX}$  spec is determined by the actual frequency regardless of Part Number (Marking Name). The following is the spec for the actual frequency.  
 0.20 ns for  $\leq 533\text{MHz}$  &  $> 500\text{MHz}$   
 0.22 ns for  $\leq 500\text{MHz}$  &  $> 450\text{MHz}$   
 0.25 ns for  $\leq 450\text{MHz}$  &  $> 400\text{MHz}$   
 0.28 ns for  $\leq 400\text{MHz}$  &  $\geq 250\text{MHz}$

Remarks:

1. Test conditions as specified with the output loading as shown in AC Test Conditions unless otherwise noted.
2. Control input signals may not be operated with pulse widths less than  $t_{KHKL}$  (min).
3.  $V_{DDQ}$  is +1.5 V DC.  $V_{REF}$  is +0.75 V DC.
4. Control signals are /R, /W (QDR series), /LD, R-/W (DDR series), /BW, /BW0, /BW1, /BW2 and /BW3. Setup and hold times of /BWx signals must be the same as those of Data-in signals.

Timing Waveforms (DDRII+, B4, Read Latency = 2.5 cycle)

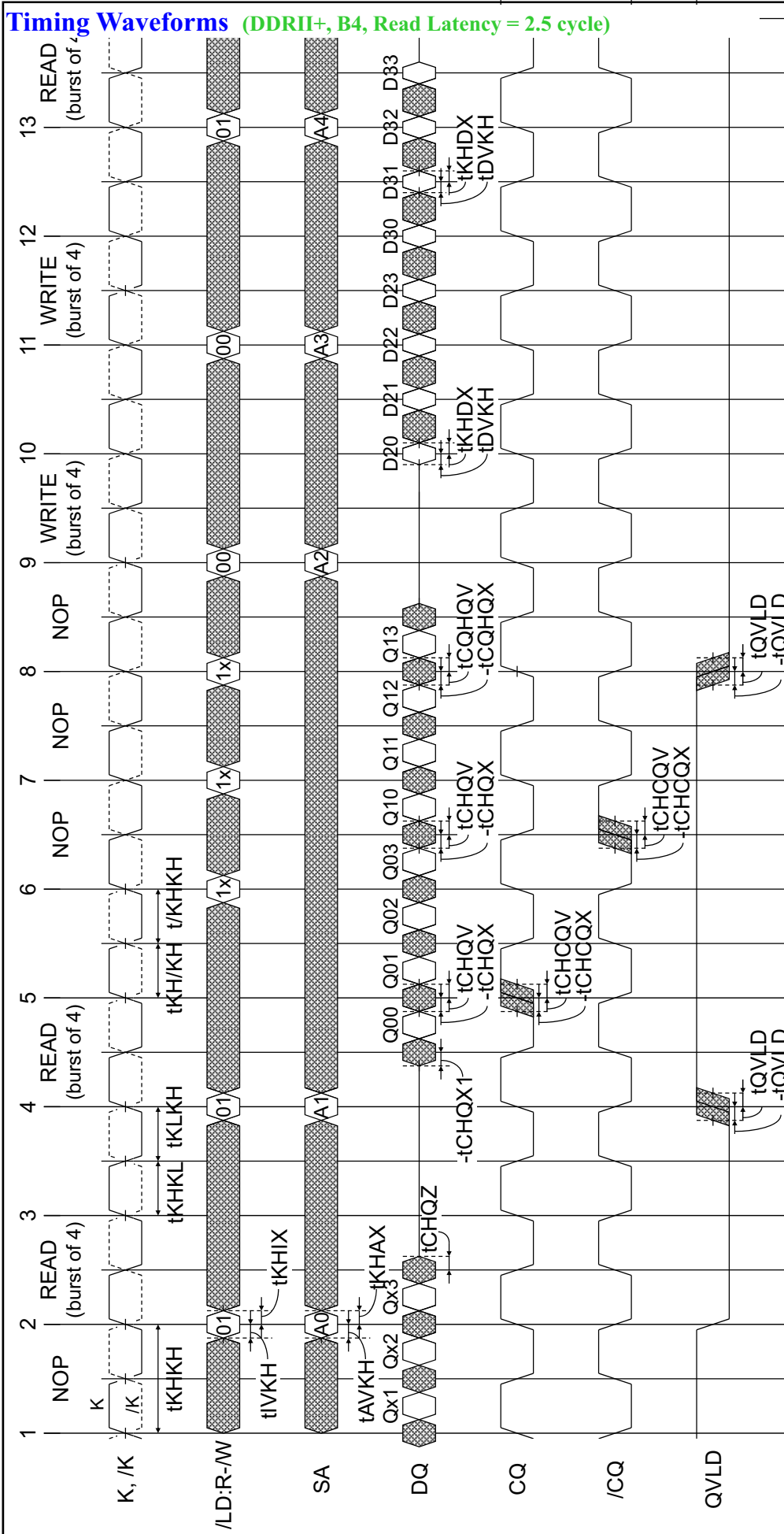

Notes:

1. Q00 refers to output from address A0. Q01 refers to output from the next internal burst address following A0, etc.
2. Outputs are disabled (high-Z) N clock cycle after the last read cycle. Here, N = Read Latency + Burst Length × 0.5.
3. In this example, if address A4 = A3, then data Q40 = D30, Q41 = D31, etc. Write data is forwarded immediately as read results.
4. To control read and write operations, /BW signals must operate at the same timing as Data-in signals.
5. The third NOP cycle is not necessary for correct device operation; however, at high clock frequencies it may be required to prevent bus contention.

## JTAG Specification

These products support a limited set of JTAG functions as in IEEE standard 1149.1.

### Disabling the Test Access Port

It is possible to use this device without utilizing the TAP. To disable the TAP controller without interfering with normal operation of the device, TCK must be tied to  $V_{SS}$  to preclude mid level inputs.

TDI and TMS are internally pulled up and may be unconnected, or may be connected to VDD through a pull up resistor.

TDO should be left unconnected.

### Test Access Port (TAP) Pins

Symbol I/O	Pin assignments	Description	Notes
TCK	2R	Test clock input. All inputs are captured on the rising edge of TCK and all outputs propagate from the falling edge of TCK.	
TMS	10R	Test mode select. This is the command input for the TAP controller state machine.	
TDI	11R	Test data input. This is the input side of the serial registers placed between TDI and TDO. The register placed between TDI and TDO is determined by the state of the TAP controller state machine and the instruction that is currently loaded in the TAP instruction.	
TDO	1R	Test data output. Output changes in response to the falling edge of TCK. This is the output side of the serial registers placed between TDI and TDO.	

**Notes:**

The device does not have TRST (TAP reset). The Test-Logic Reset state is entered while TMS is held high for five rising edges of TCK. The TAP controller state is also reset on SRAM POWER-UP.

**TAP DC Operating Characteristics**

(Ta = 0 ~ +70°C @ R1Q\*A\*\*\*\*\*BB-\*\*R\*\* series)

(Ta = -40 ~ +85°C @ R1Q\*A\*\*\*\*\*BB-\*\*I\*\* series)

(V<sub>DD</sub> = 1.8V ±0.1V)

Parameter	Symbol	Min	Typ	Max	Unit	Notes
Input high voltage	V <sub>IH</sub>	+1.3	—	V <sub>DD</sub> + 0.3	V	
Input low voltage	V <sub>IL</sub>	-0.3	—	+0.5	V	
Input leakage current	I <sub>LI</sub>	-5.0	—	+5.0	μA	0 V ≤ V <sub>IN</sub> ≤ V <sub>DD</sub>
Output leakage current	I <sub>LO</sub>	-5.0	—	+5.0	μA	0 V ≤ V <sub>IN</sub> ≤ V <sub>DD</sub> , output disabled
Output low voltage	V <sub>OL1</sub>	—	—	0.2	V	I <sub>OLC</sub> = 100 μA
	V <sub>OL2</sub>	—	—	0.4	V	I <sub>OLT</sub> = 2 mA
Output high voltage	V <sub>OH1</sub>	1.6	—	—	V	I <sub>OHC</sub>   = 100 μA
	V <sub>OH2</sub>	1.4	—	—	V	I <sub>OHT</sub>   = 2 mA

**Notes:**

- All voltages referenced to V<sub>SS</sub> (GND).
- At power-up, V<sub>DD</sub> and V<sub>DDQ</sub> are assumed to be a linear ramp from 0V to V<sub>DD</sub>(min.) or V<sub>DDQ</sub>(min.) within 200ms. During this time V<sub>DDQ</sub> < V<sub>DD</sub> and V<sub>IH</sub> < V<sub>DDQ</sub>.  
During normal operation, V<sub>DDQ</sub> must not exceed V<sub>DD</sub>.

### TAPAC Test Conditions

Parameter	Symbol	Conditions	Unit	Notes
Input timing measurement reference levels	$V_{REF}$	0.9	V	
Input pulse levels	$V_{IL}, V_{IH}$	0 to 1.8	V	
Input rise/fall time	$t_r, t_f$	$\leq 1.0$	ns	
Output timing measurement reference levels		0.9	V	
Test load termination supply voltage ( $V_{TT}$ )		0.9	V	
Output load		See figures		

#### Input waveform

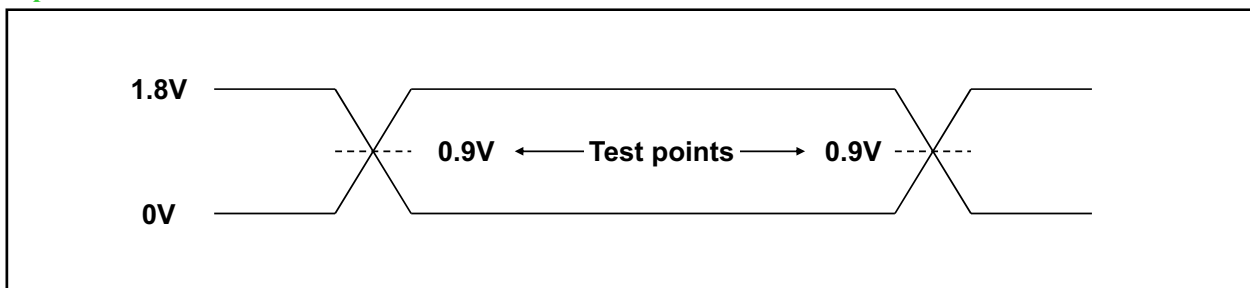

#### Output waveform

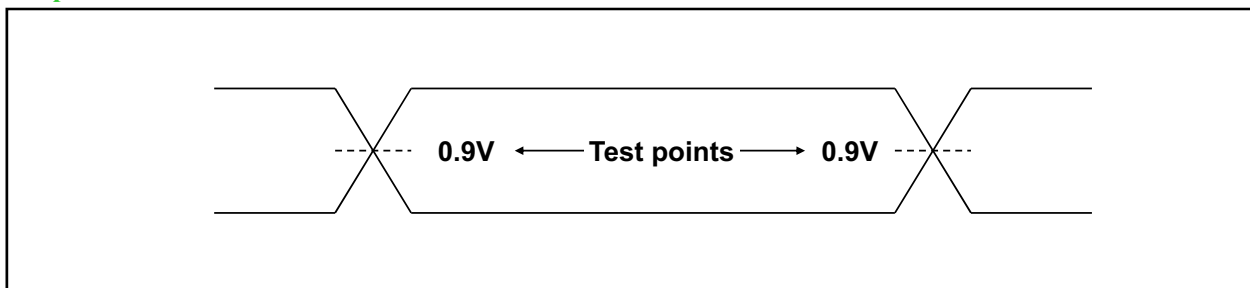

#### Output load condition

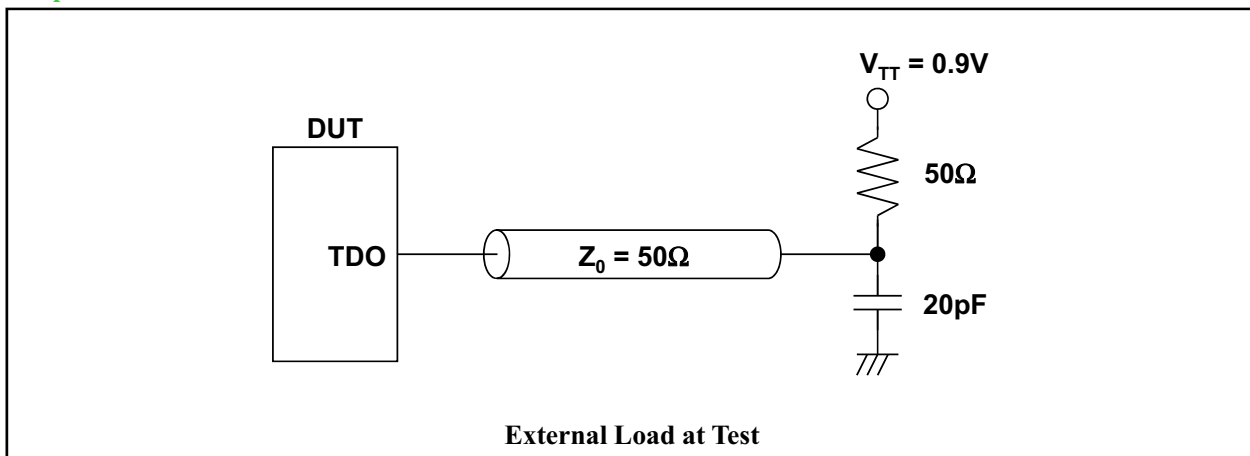

**TAPAC Operating Characteristics**

(Ta = 0 ~ +70°C @ R1Q\*A\*\*\*\*\*BB-\*\*R\*\* series)

(Ta = -40 ~ +85°C @ R1Q\*A\*\*\*\*\*BB-\*\*I\*\* series)

(V<sub>DD</sub> = 1.8V ±0.1V)

Parameter	Symbol	Min	Typ	Max	Unit	Notes
Test clock (TCK) cycle time	t <sub>THTH</sub>	50	—	—	ns	
TCK high pulse width	t <sub>THTL</sub>	20	—	—	ns	
TCK low pulse width	t <sub>TLTH</sub>	20	—	—	ns	
Test mode select (TMS) setup	t <sub>MVTH</sub>	5	—	—	ns	
TMS hold	t <sub>THMX</sub>	5	—	—	ns	
Capture setup	t <sub>CS</sub>	5	—	—	ns	1
Capture hold	t <sub>CH</sub>	5	—	—	ns	1
TDI valid to TCK high	t <sub>DVTH</sub>	5	—	—	ns	
TCK high to TDI invalid	t <sub>THDX</sub>	5	—	—	ns	
TCK low to TDO unknown	t <sub>TLQX</sub>	0	—	—	ns	
TCK low to TDO valid	t <sub>TLQV</sub>	—	—	10	ns	

Notes:

- t<sub>CS</sub> + t<sub>CH</sub> defines the minimum pause in RAM I/O pad transitions to assure pad data capture.

### TAP Controller Timing Diagram

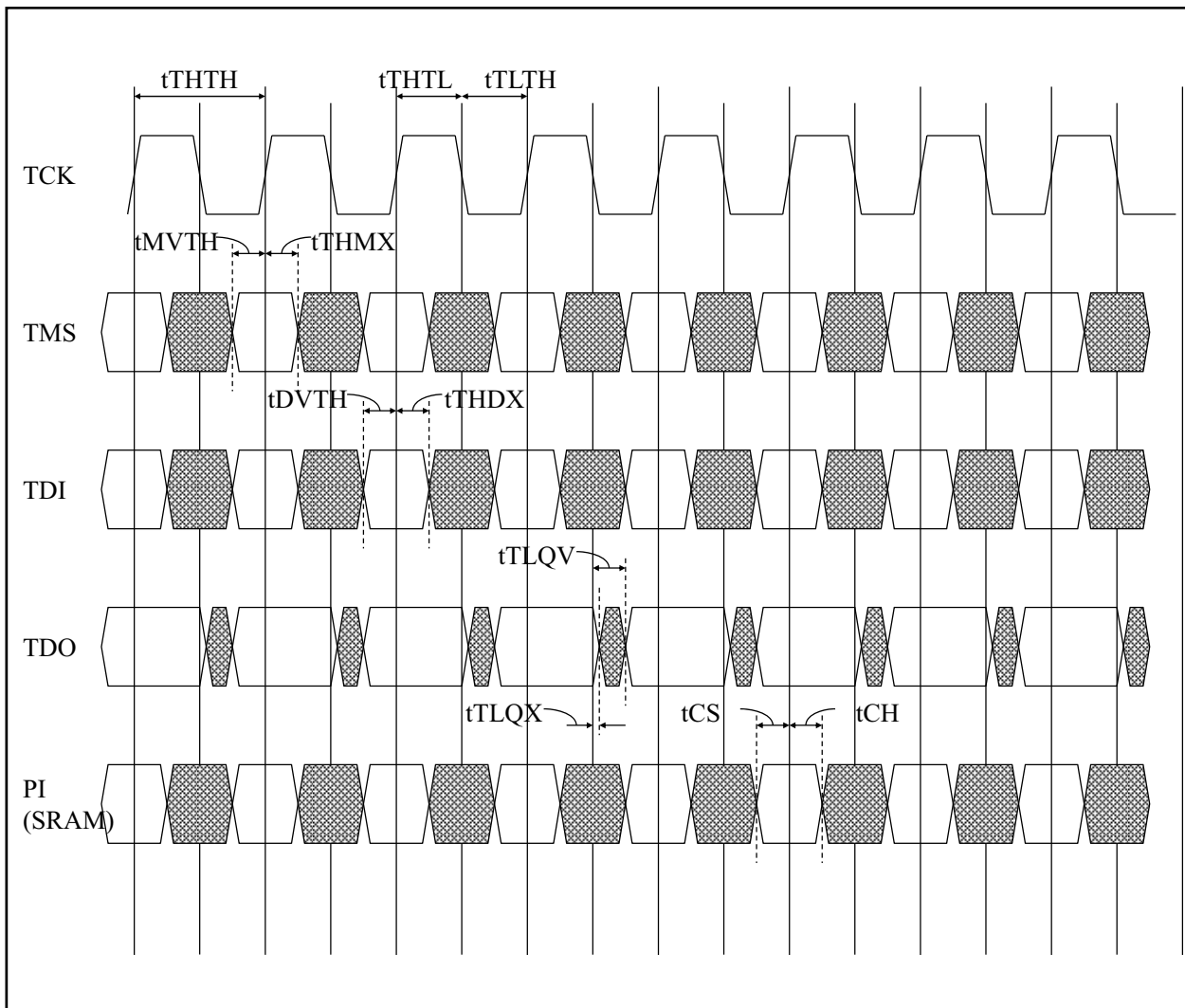

### Test Access Port Registers

Register name	Length	Symbol	Notes
Instruction register	3 bits	IR [2:0]	
Bypass register	1 bit	BP	
ID register	32 bits	ID [31:0]	
Boundary scan register	109 bits	BS [109:1]	

## TAP Controller Instruction Set

IR2	IR1	IR0	Instruction	Description	Notes
0	0	0	EXTEST	The EXTEST instruction allows circuitry external to the component package to be tested. Boundary scan register cells at output balls are used to apply test vectors, while those at input balls capture test results. Typically, the first test vector to be applied using the EXTEST instruction will be shifted into the boundary scan register using the PRELOAD instruction. Thus, during the Update-IR state of EXTEST, the output driver is turned on and the PRELOAD data is driven onto the output balls.	1, 2, 3, 5
0	0	1	IDCODE	The IDCODE instruction causes the ID ROM to be loaded into the ID register when the controller is in capture-DR mode and places the ID register between the TDI and TDO balls in shift-DR mode. The IDCODE instruction is the default instruction loaded in at power up and any time the controller is placed in the Test-Logic-Reset state.	
0	1	0	SAMPLE-Z	If the SAMPLE-Z instruction is loaded in the instruction register, all RAM outputs are forced to an inactive drive state (high-Z), moving the TAP controller into the capture-DR state loads the data in the RAMs input into the boundary scan register, and the boundary scan register is connected between TDI and TDO when the TAP controller is moved to the shift-DR state.	3, 4, 5
0	1	1	RESERVED	The RESERVED instructions are not implemented but are reserved for future use. Do not use these instructions.	
1	0	0	SAMPLE (/PRELOAD)	When the SAMPLE instruction is loaded in the instruction register, moving the TAP controller into the capture-DR state loads the data in the RAMs input and I/O buffers into the boundary scan register. Because the RAM clock(s) are independent from the TAP clock (TCK) it is possible for the TAP to attempt to capture the I/O ring contents while the input buffers are in transition (i.e., in a metastable state). Although allowing the TAP to SAMPLE metastable input will not harm the device, repeatable results cannot be expected. Moving the controller to shift-DR state then places the boundary scan register between the TDI and TDO balls.	3, 5
1	0	1	RESERVED	-	
1	1	0	RESERVED	-	
1	1	1	BYPASS	The BYPASS instruction is loaded in the instruction register when the bypass register is placed between TDI and TDO. This occurs when the TAP controller is moved to the shift-DR state. This allows the board level scan path to be shortened to facilitate testing of other devices in the scan path.	

## Notes:

1. Data in output register is not guaranteed if EXTEST instruction is loaded.
2. After performing EXTEST, power-up conditions are required in order to return part to normal operation.
3. RAM input signals must be stabilized for long enough to meet the TAPs input data capture setup plus hold time ( $t_{CS}$  plus  $t_{CH}$ ). The RAMs clock inputs need not be paused for any other TAP operation except capturing the I/O ring contents into the boundary scan register.
4. Clock recovery initialization cycles are required after boundary scan.
5. For R1QD, R1QE, R1QF, R1QK, R1QL, R1QM, R1QP series, ODT is disabled in EXTEST, SAMPLE-Z or SAMPLE mode.

## Boundary Scan Order

Bit #	Ball ID	Signal names			Bit #	Ball ID	Signal names		
		x9	x18	x36			x9	x18	x36
1	6R	/C or NC or ODT	/C or NC or ODT	/C or NC or ODT	36	10E	NC	NC	DQ15
2	6P	C or QVLD	C or QVLD	C or QVLD	37	10D	NC	NC	NC
3	6N	SA	SA	SA	38	9E	NC	NC	NC
4	7P	SA	SA	SA	39	10C	NC	DQ7	DQ17
5	7N	SA	SA	SA	40	11D	NC	NC	DQ16
6	7R	SA	SA	SA	41	9C	NC	NC	NC
7	8R	SA	SA	SA	42	9D	NC	NC	NC
8	8P	SA	SA	SA	43	11B	DQ4	DQ8	DQ8
9	9R	SA	SA	SA	44	11C	NC	NC	DQ7
10	11P	DQ0	DQ0	DQ0	45	9B	NC	NC	NC
11	10P	NC	NC	DQ9	46	10B	NC	NC	NC
12	10N	NC	NC	NC	47	11A	CQ	CQ	CQ
13	9P	NC	NC	NC	48	10A	SA	SA	SA
14	10M	NC	DQ1	DQ11	49	9A	SA	SA	SA
15	11N	NC	NC	DQ10	50	8B	SA	SA	SA
16	9M	NC	NC	NC	51	7C	SA	SA1 or NC	SA1 or NC
17	9N	NC	NC	NC	52	6C	NC	SA0 or NC	SA0 or NC
18	11L	DQ1	DQ2	DQ2	53	8A	/LD	/LD	/LD
19	11M	NC	NC	DQ1	54	7A	NC	NC	/BW1
20	9L	NC	NC	NC	55	7B	/BW	/BW0	/BW0
21	10L	NC	NC	NC	56	6B	K	K	K
22	11K	NC	DQ3	DQ3	57	6A	/K	/K	/K
23	10K	NC	NC	DQ12	58	5B	NC	NC	/BW3
24	9J	NC	NC	NC	59	5A	NC	/BW1	/BW2
25	9K	NC	NC	NC	60	4A	R-/W	R-/W	R-/W
26	10J	DQ2	DQ4	DQ13	61	5C	SA	SA	SA
27	11J	NC	NC	DQ4	62	4B	SA	SA	SA
28	11H	ZQ	ZQ	ZQ	63	3A	SA	SA	SA
29	10G	NC	NC	NC	64	2A	SA	SA	NC
30	9G	NC	NC	NC	65	1A	/CQ	/CQ	/CQ
31	11F	NC	DQ5	DQ5	66	2B	NC	DQ9	DQ27
32	11G	NC	NC	DQ14	67	3B	NC	NC	DQ18
33	9F	NC	NC	NC	68	1C	NC	NC	NC
34	10F	NC	NC	NC	69	1B	NC	NC	NC
35	11E	DQ3	DQ6	DQ6	70	3D	NC	DQ10	DQ19

## Boundary Scan Order

Bit #	Ball ID	Signal names			Bit #	Ball ID	Signal names		
		x9	x18	x36			x9	x18	x36
71	3C	NC	NC	DQ28	91	2L	DQ7	DQ15	DQ33
72	1D	NC	NC	NC	92	3L	NC	NC	DQ24
73	2C	NC	NC	NC	93	1M	NC	NC	NC
74	3E	DQ5	DQ11	DQ20	94	1L	NC	NC	NC
75	2D	NC	NC	DQ29	95	3N	NC	DQ16	DQ25
76	2E	NC	NC	NC	96	3M	NC	NC	DQ34
77	1E	NC	NC	NC	97	1N	NC	NC	NC
78	2F	NC	DQ12	DQ30	98	2M	NC	NC	NC
79	3F	NC	NC	DQ21	99	3P	DQ8	DQ17	DQ26
80	1G	NC	NC	NC	100	2N	NC	NC	DQ35
81	1F	NC	NC	NC	101	2P	NC	NC	NC
82	3G	DQ6	DQ13	DQ22	102	1P	NC	NC	NC
83	2G	NC	NC	DQ31	103	3R	SA	SA	SA
84	1H	/DOFF	/DOFF	/DOFF	104	4R	SA	SA	SA
85	1J	NC	NC	NC	105	4P	SA	SA	SA
86	2J	NC	NC	NC	106	5P	SA	SA	SA
87	3K	NC	DQ14	DQ23	107	5N	SA	SA	SA
88	3J	NC	NC	DQ32	108	5R	SA	SA	SA
89	2K	NC	NC	NC	109	—	INTER- NAL	INTER- NAL	INTER- NAL
90	1K	NC	NC	NC	—	—	—	—	—

## Notes:

In boundary scan mode,

1. Clock balls (K, /K, C, /C) are referenced to each other and must be at opposite logic levels for reliable operation.
2. CQ and /CQ data are synchronized to the respective C and /C (except EXTEST, SAMPLE-Z).
3. If C and /C tied high, CQ is generated with respect to K and /CQ is generated with respect to /K (except EXTEST, SAMPLE-Z).



### Package Dimensions and Marking Information

Both Pb parts and Pb-free parts are available.

JEITA Package Code	Renesas Code	Previous Code	Mass (typ.)
P-LBGA165-13x15-1.00	PLBG0165FE-A	165FHG	0.5g

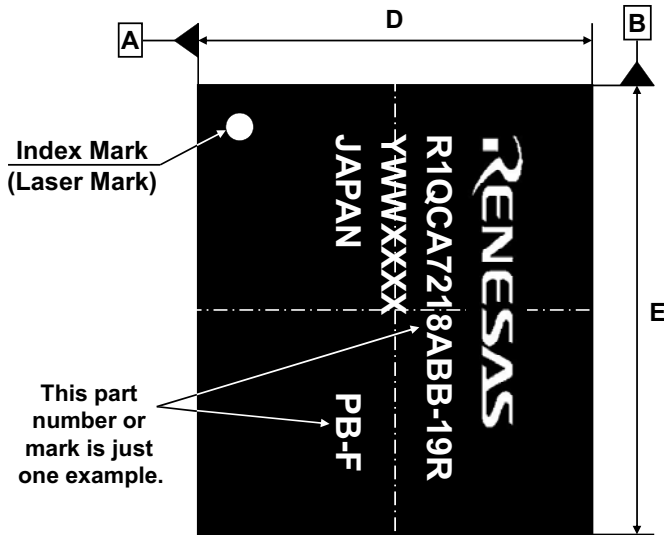

### Top View

Marking Information	
1st row :	Vender name (RENESAS)
2nd row :	Part number
3rd row :	Y : Year code
	WW : Week code
	XXXX : Renesas internal use
4th row :	Country name (JAPAN)
	+ "None" --- Pb parts
	+ "PB-F" --- Pb-free parts

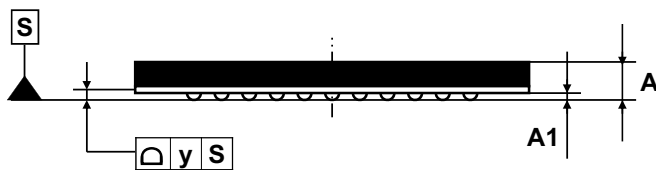

### Side View

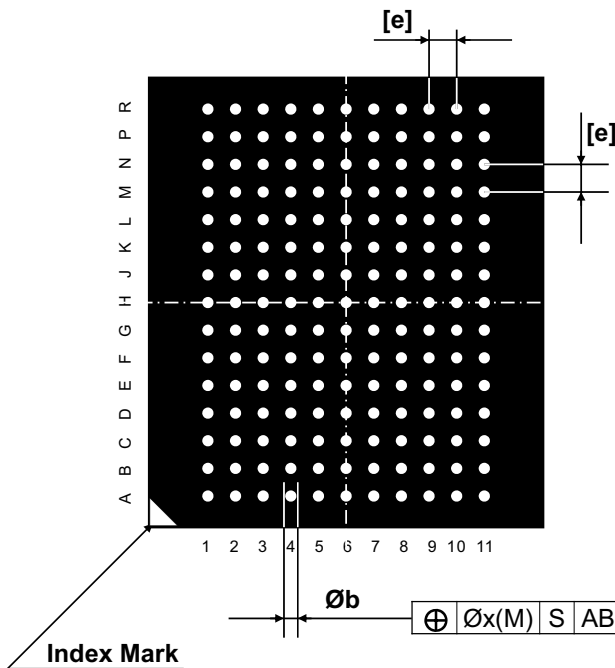

### Bottom View

Reference Symbol	Dimension in mm		
	Min	Nom	Max
D	12.9	13.0	13.1
E	14.9	15.0	15.1
A	-	-	1.4
A1	0.31	0.36	0.41
[e]	-	1.0	-
b	0.45	0.5	0.6
x	-	-	0.2
y	-	-	0.15

## Revision History (1)

Rev.	Date	#	Comment
Rev. 0.00a	'08.10.08	1	Initial issue.
Rev. 0.00b	'08.10.09	1	Corrected typos in "DC Characteristics": VOH/VOL= VDDQ/2±1.12 → ±0.12.
Rev. 0.00c	'08.11.19	1	Added "Speed Bin Table". Added "ODT timing chart" to QDR11+ and DDR11+ series.
Rev. 0.00d	'08.11.28	1	Corrected typos in "General Description": ODT pin = Q0~Qn → D0~Dn.
		2	Updated "Recommended DC Operating Conditions": Vref =0.68~0.95V → 0.7~0.8V (11+ series).
		3	Added comment to "Thermal Resistance" section: These are reference values.
Rev. 0.00e	'08.12.07	1	Added "Generation Number Table".
Rev. 0.00f -1	'09.02.09	1	Changed Marking Name in "Part Number Definition Table".
		2	Added marking information to "Package Dimension Information" section.
		3	Corrected ODT On/Off timing in "ODT pin" table.
		4	Updated minimum frequency of QDR11+ and DDR11+ series.
		5	Changed pin name in "Pin Arrangement" of DDR11+ series: SA0/SA1 → NC.
		6	Added the row to "K Truth Table": RL=2.0 and RL=2.5.
Rev. 0.00g -1	'09.02.24	1	Updated SET-UP cycles: 11+ series DLL lock time = 20us → 2048 cycle.
		2	Added comment to "ODT on/off Timing Chart" section: ODT on/off switching timings are edge aligned with CQ or /CQ.
		3	Updated "Thermal Resistance".
Rev. 0.00h	'09.03.04	1	Added "-50" speed bin to QDR 11 B2 x18/x36 series.
Rev. 0.00i	'09.06.15	1	Updated "Package Dimensions": Mass=0.7→0.6g, A(max)=1.46→1.4mm.
		2	Updated "Operating/Standby Supply Currents".
Rev. 0.01a	'09.10.25	1	Added comment to "Power-up and Initialization Sequence" section: Apply Vref after Vddq or at the same time as Vddq.
		2	Updated "Speed Bin Table".
Rev. 0.02a	'10.02.01	1	Added "Renesas QDR SRAM Homepage URL" to notes of front page.
		2	Updated "Power-up and Initialization Sequence".
		3	Updated "DLL Constraints".
		4	Updated "Operating Supply Current" and "Standby Supply Current"
		5	Updated "Thermal Resistance".
		6	Changed remarks of "AC Characteristics" on "Control signals".
Rev. 0.03a	'10.04.01	1	Changed company name, RENESAS logo and base color from those of Renesas Technology to Renesas Electronics.
		2	Changed vender name marking in "Package Dimensions and Marking Information" section.
		3	Added "A" generation to 72M series.
Rev. 0.04a	'10.06.10	1	Changed the pin description for NC pin.
		2	Changed note 4 of "TAP Controller Instruction Set": "Clock recovery initialization cycles are required after boundary scan"
Rev. 0.05a	'10.06.25	1	Changed Vddq range of 11+ series: Vddq=1.5±0.1V → 1.4V ~ Vdd.
		2	Added Note.8 and Note.9 to AC Characteristics table for 11+ series.
		3	Updated Speed Bin Table for 144M.
Rev. 0.05b	'10.07.02	1	Added Note.2 to Generation Number Table.
		2	Updated Speed Bin Table for 36M and 72M.
Rev. 0.05c	'10.07.24	1	Updated Operating Supply Current and Standby Supply Current Table for 36M and 72M.
Rev. 0.06a	'10.09.20	1	Changed Initialization Sequence: Initial cycle of 11+ series = 2048cycles → 20us.
Rev. 0.07a	'10.10.06	1	Added Note.9 to AC Characteristics table for 11 series.
Rev. 0.07b	'10.10.30	1	Updated AC Characteristics for the series of RL=2.0.
		2	Updated Speed Bin Table for 72M/36M/144M.
		3	Added R1QNA, R1QPA series to 144M QDR lineup.
		4	Changed JTAG/ID Register (ID Code): #27="0": 36M&72M w/o ODT, 144M, 288M "1": 36M&72M w/ ODT #23="0": 144M&288M w/o ODT, 36M, 72M "1": 144M&288M w/ ODT #(26, 25, 24)="100"→"101" (144M), "101"→"110" (288M).

## Revision History (2)

Rev.	Date	#	Comment
Rev.0.08a	11.05.23	1	Added Note.7 to tQVLD in AC Characteristics table for II+ series.
		2	Changed description of tQVLD in AC Characteristics table for RL=2 series: CQ high to QVLD valid → /CQ high to QVLD valid.
		3	Updated Remarks 4 of AC Characteristics table.
		4	Updated tKHKH(max) in AC Characteristics table for QDRII+ B2 series.
		5	Added 13 x15 mm package lineup to 36M II+ & 72M II/II+ series.
Rev.0.08b	11.07.17	1	Updated "Package Dimensions" for 13 x15 mm package.
		2	Updated "Thermal Resistance" for 13 x15 mm package.
		3	Changed Title: "Ordering Informaion" → "Part Number Definition", "Speed Bin Table" → "Renesas **M QDR/DDR SRAM Lineup"
Rev.0.09a	11.09.14	1	Updated Specification for ODT Option 2.
Rev.0.10a	11.12.09	1	Updated Part Number Definition table.(Added Note.4)
Rev.0.10b	12.03.12	1	Updated Part Number Definition table.(Added definition to No.10-11)
Rev.0.10c	12.06.05	1	Updated URL for Renesas QDR SRAM Homepage.
Rev.0.11	13.01.15	1	Updated "Part Number Definition" for 13 x 15 mm Package

NOTES:

1. This document is provided for reference purposes only so that Renesas customers may select the appropriate Renesas products for their use. Renesas neither makes warranties or representations with respect to the accuracy or completeness of the information contained in this document nor grants any license to any intellectual property rights or any other rights of Renesas or any third party with respect to the information in this document.
2. Renesas shall have no liability for damages or infringement of any intellectual property or other rights arising out of the use of any information in this document, including, but not limited to, product data, diagrams, charts, programs, algorithms, and application circuit examples.
3. You should not use the products or the technology described in this document for the purpose of military applications such as the development of weapons of mass destruction or for the purpose of any other military use. When exporting the products or technology described herein, you should follow the applicable export control laws and regulations, and procedures required by such laws and regulations.
4. All information included in this document such as product data, diagrams, charts, programs, algorithms, and application circuit examples, is current as of the date this document is issued. Such information, however, is subject to change without any prior notice. Before purchasing or using any Renesas products listed in this document, please confirm the latest product information with a Renesas sales office. Also, please pay regular and careful attention to additional and different information to be disclosed by Renesas such as that disclosed through our website. (<http://www.renesas.com>)
5. Renesas has used reasonable care in compiling the information included in this document, but Renesas assumes no liability whatsoever for any damages incurred as a result of errors or omissions in the information included in this document.
6. When using or otherwise relying on the information in this document, you should evaluate the information in light of the total system before deciding about the applicability of such information to the intended application. Renesas makes no representations, warranties or guarantees regarding the suitability of its products for any particular application and specifically disclaims any liability arising out of the application and use of the information in this document or Renesas products.
7. The products described in this document are intended for usage in general electronics applications (computer, personal equipment, office equipment, measuring equipment, industrial robotics, domestic appliances, etc.). The products are not designed, manufactured, tested or warranted for applications or otherwise in systems the failure or malfunction of which may cause a direct threat to human life or create a risk of human injury or which require especially high quality and reliability such as safety systems, or equipment or systems for transportation and traffic, healthcare, combustion control, aerospace and aeronautics, nuclear power, or undersea communication transmission. Unintended usage of the products shall be made at the customer's own risk. Renesas shall have no liability for damages arising out of the uses set forth above.
8. Notwithstanding the preceding paragraph, you should not use Renesas products for the purposes listed below:
  - (1) artificial life support devices or systems
  - (2) surgical implantations
  - (3) healthcare intervention (e.g., excision, administration of medication, etc.)
  - (4) any other purposes that pose a direct threat to human lifeRenesas shall have no liability for damages arising out of the uses set forth in the above and purchasers who elect to use Renesas products in any of the foregoing applications shall indemnify and hold harmless Renesas Electronics Corp., its affiliated companies and their officers, directors, and employees against any and all damages arising out of such applications.
9. You should use the products described herein within the range specified by Renesas, especially with respect to the maximum rating, operating supply voltage range, movement power voltage range, heat radiation characteristics, installation and other product characteristics. Renesas shall have no liability for malfunctions or damages arising out of the use of Renesas products beyond such specified ranges.
10. Although Renesas endeavors to improve the quality and reliability of its products, IC products have specific characteristics such as the occurrence of failure at a certain rate and malfunctions under certain use conditions. Please be sure to implement safety measures to guard against the possibility of physical injury, and injury or damage caused by fire in the event of the failure of a Renesas product, such as safety design for hardware and software including but not limited to redundancy, fire control and malfunction prevention, appropriate treatment for aging degradation or any other applicable measures. Among others, since the evaluation of microcomputer software alone is very difficult, please evaluate the safety of the final products or system manufactured by you.
11. In case Renesas products listed in this document are detached from the products to which the Renesas products are attached or affixed, the risk of accident such as swallowing by infants and small children is very high. You should implement safety measures so that Renesas products may not be easily detached from your products. Renesas shall have no liability for damages arising out of such detachment.
12. This document may not be reproduced or duplicated, in any form, in whole or in part, without prior written approval from Renesas.
13. Please contact a Renesas sales office if you have any questions regarding the information contained in this document, Renesas semiconductor products, or if you have any other inquiries.

**Renesas Sales Offices**



<http://www.renesas.com>

Refer to "<http://www.renesas.com/>" for the latest and detailed information.

**Renesas Electronics America Inc.**

2880 Scott Boulevard Santa Clara, CA 95050-2554, U.S.A.  
Tel: +1-408-588-6000, Fax: +1-408-588-6130

**Renesas Electronics Canada Limited**

1101 Nicholson Road, Newmarket, Ontario L3Y 9C3, Canada  
Tel: +1-905-898-5441, Fax: +1-905-898-3220

**Renesas Electronics Europe Limited**

Dukes Meadow, Millboard Road, Bourne End, Buckinghamshire,  
SL8 5FH, U.K  
Tel: +44-1628-585-100, Fax: +44-1628-585-900

**Renesas Electronics Europe GmbH**

Arcadiastrasse 10, 40472 Düsseldorf, Germany  
Tel: +49-211-6503-0, Fax: +49-211-6503-1327

**Renesas Electronics (China) Co., Ltd.**

7th Floor, Quantum Plaza, No.27 ZhiChunLu Haidian District,  
Beijing 100083, P.R.China  
Tel: +86-10-8235-1155, Fax: +86-10-8235-7679

**Renesas Electronics (Shanghai) Co., Ltd.**

Unit 204, 205, AZIA Center, No.1233 Lujiazui Ring Rd., Pudong District,  
Shanghai 200120, China  
Tel: +86-21-5877-1818, Fax: +86-21-6887-7858 / -7898

**Renesas Electronics Hong Kong Limited**

Unit 1601-1613, 16/F., Tower 2, Grand Century Place,  
193 Prince Edward Road West, Mongkok, Kowloon, Hong Kong  
Tel: +852-2886-9318, Fax: +852 2886-9022/9044

**Renesas Electronics Taiwan Co., Ltd.**

7F, No. 363 Fu Shing North Road Taipei, Taiwan, R.O.C.  
Tel: +886-2-8175-9600, Fax: +886 2-8175-9670

**Renesas Electronics Singapore Pte. Ltd.**

1 harbourFront Avenue, #06-10, keppel Bay Tower, Singapore 098632  
Tel: +65-6213-0200, Fax: +65-6278-8001

**Renesas Electronics Malaysia Sdn.Bhd.**

Unit 906, Block B, Menara Amcorp, Amcorp Trade Centre, No. 18,  
Jln Persiaran Barat, 46050 Petaling Jaya, Selangor Darul Ehsan, Malaysia  
Tel: +60-3-7955-9390, Fax: +60-3-7955-9510

**Renesas Electronics Korea Co., Ltd.**

11F., Samik Lavied' or Bldg., 720-2 Yeoksam-Dong, Kangnam-Ku,  
Seoul 135-080, Korea  
Tel: +82-2-558-3737, Fax: +82-2-558-5141