

**PRODUCT  
PREVIEW**

018338  
**SN54AS182, SN74AS182  
LOOK-AHEAD CARRY GENERATOR**

D2661, DECEMBER 1983—REVISED MAY 1986

- High-Speed Replacement for the 'S182
- Offers Carry Functions in a Compatible Form for Direct Connections to the ALU
- Cascadable to Perform Look-Ahead Across n-Bit Adders
- Package Options Include Plastic "Small Outline" Packages, Ceramic Chip Carriers, and Standard Plastic and Ceramic 300-mil DIPs
- Dependable Texas Instruments Quality and Reliability

SN54AS182 . . . J PACKAGE  
SN74AS182 . . . D OR N PACKAGE  
(TOP VIEW)

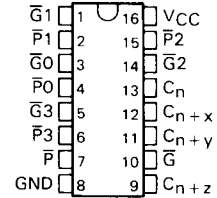

SN54AS182 . . . FK PACKAGE  
(TOP VIEW)

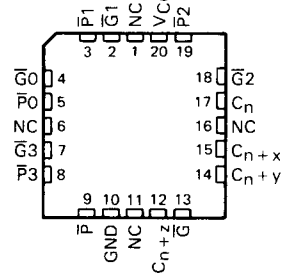

**PIN DESIGNATIONS**

ALTERNATIVE	DESIGNATIONS <sup>†</sup>	FUNCTION
$\overline{G}0, \overline{G}1, \overline{G}2, \overline{G}3$	G0, G1, G2, G3	Carry Generate Inputs
$\overline{P}0, \overline{P}1, \overline{P}2, \overline{P}3$	P0, P1, P2, P3	Carry Propagate Inputs
$C_n$	$\overline{C}_n$	Carry Input
$C_{n+x}, C_{n+y}, C_{n+z}$	$\overline{C}_{n+x}, \overline{C}_{n+y}, \overline{C}_{n+z}$	Carry Outputs
$\overline{G}$	Y	Carry Generate Output
$\overline{P}$	X	Carry Propagate Output
$V_{CC}$		Supply Voltage
GND		Ground

<sup>†</sup> Interpretations are illustrated in connection with the Function Tables for the 'AS181B and 'AS881A.

**description**

The 'AS182 look-ahead carry generators are capable of anticipating a carry across four binary adders or group of adders. They are cascadable to perform full look-ahead across n-bit adders.

This generator, when used in conjunction with the 'AS181B or 'AS881A Arithmetic Logic Unit ALU, provides high-speed carry look-ahead capability for any word length. The 'AS182 generates the look-ahead (anticipated carry) across a group of four ALUs. In addition, other carry look-ahead circuits may be employed to anticipate carry-across sections of four look-ahead packages up to n-bits. The method of cascading 'AS182 circuits to perform multilevel look-ahead is illustrated under the typical application data.

The carry functions (inputs, outputs, generate, and propagate) of the look-ahead generators are implemented in the compatible forms for direct connections to the ALU. Reinterpretations of carry functions as explained on the 'AS181B and 'AS881A data sheet are also applicable to and compatible with the look-ahead generator. Logic equations for the 'AS182 are:

$$\begin{aligned}
 C_{n+x} &= G0 + P0 C_n & \overline{C}_{n+x} &= \overline{Y0 (X0 + C_n)} \\
 C_{n+y} &= G1 + P1 G0 + P1 P0 C_n & \overline{C}_{n+y} &= \overline{Y1 [X1 + Y0 (X0 + C_n)]} \\
 C_{n+z} &= G2 + P2 G1 + P2 P1 G0 + P2 P1 P0 C_n & \overline{C}_{n+z} &= \overline{Y2 \{ X2 + Y1 [X1 + Y0 (X0 + C_n)] \}} \\
 \overline{G} &= \overline{G3 + P3 G2 + P3 P2 G1 + P3 P2 P1 G0} & Y &= Y3 (X3 + Y2) (X3 + X2 + Y1) (X3 + X2 + X1 + Y0) \\
 \overline{P} &= \overline{P3 P2 P1 P0} & X &= X3 + X2 + X1 + X0
 \end{aligned}$$

PRODUCT PREVIEW documents contain information on products in the formative or design phase of development. Characteristic data and other specifications are design goals. Texas Instruments reserves the right to change or discontinue these products without notice.



POST OFFICE BOX 655012 • DALLAS, TEXAS 75265

Copyright © 1983, Texas Instruments Incorporated

# SN54AS182, SN74AS182 LOOK-AHEAD CARRY GENERATOR

**FUNCTION TABLE FOR  $\bar{G}$  OUTPUT**

INPUTS						OUTPUT	
$\bar{G}_3$	$\bar{G}_2$	$\bar{G}_1$	$\bar{G}_0$	$\bar{P}_3$	$\bar{P}_2$	$\bar{P}_1$	$\bar{G}$
L	X	X	X	X	X	X	L
X	L	X	X	L	X	X	L
X	X	L	X	L	L	X	L
X	X	X	L	L	L	L	L
All other combinations							H

**FUNCTION TABLE FOR  $\bar{P}$  OUTPUT**

INPUTS				OUTPUT
$\bar{P}_3$	$\bar{P}_2$	$\bar{P}_1$	$\bar{P}_0$	$\bar{P}$
L	L	L	L	L
All other combinations				H

**FUNCTION TABLE FOR  $C_{n+x}$  OUTPUT**

INPUTS			OUTPUT
$\bar{G}_0$	$\bar{P}_0$	$C_n$	$C_{n+x}$
L	X	X	H
X	L	H	H
All other combinations			L

**FUNCTION TABLE  $C_{n+y}$  OUTPUT**

INPUTS					OUTPUT
$\bar{G}_1$	$\bar{G}_0$	$\bar{P}_1$	$\bar{P}_0$	$C_n$	$C_{n+y}$
L	X	X	X	X	H
X	L	L	X	X	H
X	X	L	L	H	H
All other combinations					L

**FUNCTION TABLE FOR  $C_{n+z}$  OUTPUT**

INPUTS							OUTPUT
$\bar{G}_2$	$\bar{G}_1$	$\bar{G}_0$	$\bar{P}_2$	$\bar{P}_1$	$\bar{P}_0$	$C_n$	$C_{n+z}$
L	X	X	X	X	X	X	H
X	L	X	L	X	X	X	H
X	X	L	L	L	X	X	H
X	X	X	L	L	L	H	H
All other combinations							L

H = high-level, L = low level, X = irrelevant.  
Any inputs not shown in a given table are irrelevant with respect to that output.

## logic diagram (positive logic)

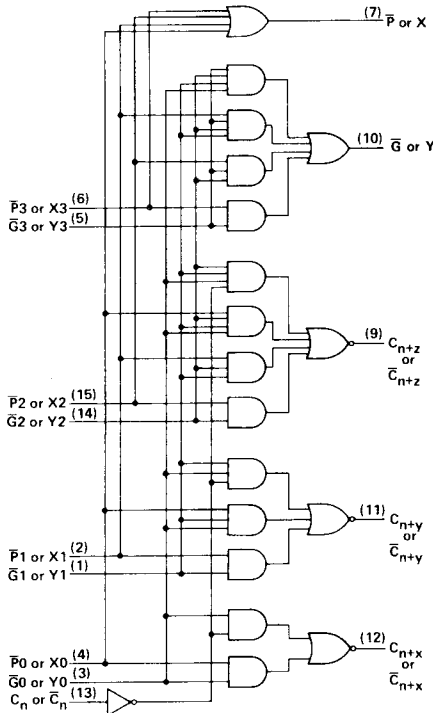

## logic symbols†

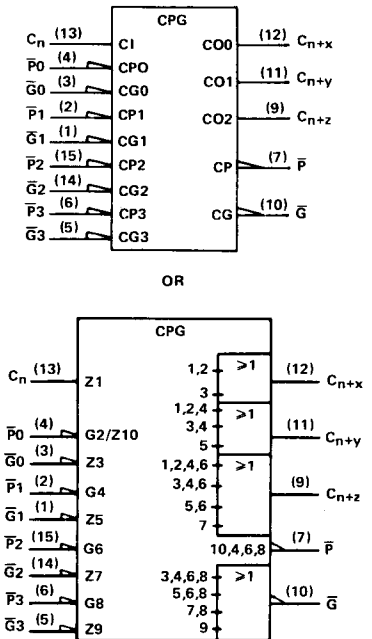

†These symbols are in accordance with ANSI/IEEE Std 91-1984 and IEC Publication 617-12.  
Pin numbers are for D, J, and N packages.

2

ALS and AS Circuits

# SN54AS182, SN74AS182 LOOK-AHEAD CARRY GENERATOR

## absolute maximum ratings over operating free-air temperature range (unless otherwise noted)

Supply voltage, $V_{CC}$ .....	7 V
Input voltage .....	7 V
Operating free-air temperature range: SN54AS182 .....	-55°C to 125°C
SN74AS182 .....	0°C to 70°C
Storage temperature range .....	-65°C to 150°C

## recommended operating conditions

	SN54AS182			SN74AS182			UNIT
	MIN	NOM	MAX	MIN	NOM	MAX	
$V_{CC}$ Supply voltage	4.5	5	5.5	4.5	5	5.5	V
$V_{IH}$ High-level input voltage	2			2			V
$V_{IL}$ Low-level input voltage			0.8			0.8	V
$I_{OH}$ High-level output current			-2			-2	mA
$I_{OL}$ Low-level output current			20			20	mA
$T_A$ Operating free-air temperature	-55		125	0		70°	°C

## electrical characteristics over recommended operating free-air temperature range (unless otherwise noted)

PARAMETER	TEST CONDITIONS	SN54AS182			SN74AS182			UNIT
		MIN	TYP <sup>†</sup>	MAX	MIN	TYP <sup>†</sup>	MAX	
$V_{IK}$	$V_{CC} = 4.5 \text{ V}$ , $I_I = -18 \text{ mA}$			-1.2			-1.2	V
$V_{OH}$	$V_{CC} = 4.5 \text{ V to } 5.5 \text{ V}$ , $I_{OH} = -2 \text{ mA}$	$V_{CC} - 2$			$V_{CC} - 2$			V
$V_{OL}$	$V_{CC} = 4.5 \text{ V}$ , $I_{OL} = 20 \text{ mA}$		0.3	0.5		0.3	0.5	V
$I_I$	$C_n$	$V_{CC} = 5.5 \text{ V}$ ,	$V_I = 7.0 \text{ V}$			0.1	0.1	mA
	$\bar{P}3$					0.2	0.2	
	$\bar{P}2$					0.3	0.3	
	$\bar{P}0, \bar{P}1, \bar{G}3$					0.4	0.4	
	$\bar{G}0, \bar{G}2$					0.7	0.7	
	$\bar{G}1$					0.8	0.8	
$I_{IH}$	$C_n$	$V_{CC} = 5.5 \text{ V}$ ,	$V_I = 2.7 \text{ V}$			0.02	0.02	mA
	$\bar{P}3$					0.04	0.04	
	$\bar{P}2$					0.06	0.06	
	$\bar{P}0, \bar{P}1, \bar{G}3$					0.08	0.08	
	$\bar{G}0, \bar{G}2$					0.14	0.14	
	$\bar{G}1$					0.16	0.16	
$I_{IL}$	$C_n$	$V_{CC} = 5.5 \text{ V}$ ,	$V_I = 0.4 \text{ V}$			-0.5	-0.5	mA
	$\bar{P}3$					-1	-1	
	$\bar{P}2$					-1.5	-1.5	
	$\bar{P}0, \bar{P}1, \bar{G}3$					-2	-2	
	$\bar{G}0, \bar{G}2$					-3.5	-3.5	
	$\bar{G}1$					-4	-4	
$I_O^\ddagger$	$V_{CC} = 5.5 \text{ V}$ , $V_O = 2.25 \text{ V}$		-30	-112		-30	-112	mA
$I_{CCH}$	$V_{CC} = 5.5 \text{ V}$		17			17		mA
$I_{CCL}$	$V_{CC} = 5.5 \text{ V}$		23			23		mA

<sup>†</sup>All typical values are at  $V_{CC} = 5 \text{ V}$ ,  $T_A = 25^\circ\text{C}$ .

<sup>‡</sup>The output conditions have been chosen to produce a current that closely approximates one-half of the true short-circuit current,  $I_{OS}$ .

# SN54AS182, SN74AS182 LOOK-AHEAD CARRY GENERATOR

switching characteristics (see Note 1)

PARAMETER	FROM (INPUT)	TO (OUTPUT)	$V_{CC} = 4.5 \text{ V to } 5.5 \text{ V},$ $C_L = 50 \text{ pF},$ $R_L = 500 \Omega,$ $T_A = \text{MIN to MAX}$						UNIT
			SN54AS182			SN74AS182			
			MIN	TYP†	MAX	MIN	TYP†	MAX	
$t_{PLH}$	$C_n$	$C_{n+x}, C_{n+y}$	5			5			ns
$t_{PHL}$			5			5			
$t_{PLH}$	Any $\bar{P}$ or $\bar{G}$	$C_{n+x}, C_{n+y}$	5			5			ns
$t_{PHL}$			5			5			
$t_{PLH}$	Any $\bar{P}$ or $\bar{G}$	$\bar{G}$	6			6			ns
$t_{PHL}$			5			5			
$t_{PLH}$	Any $\bar{P}$	$\bar{P}$	5			5			ns
$t_{PHL}$			5			5			

†All typical values are at  $V_{CC} = 5 \text{ V}, T_A = 25^\circ\text{C}.$

NOTE 1: Load circuit and voltage waveforms are shown in Section 1.

## TYPICAL APPLICATION DATA

'AS181B, 'AS881A

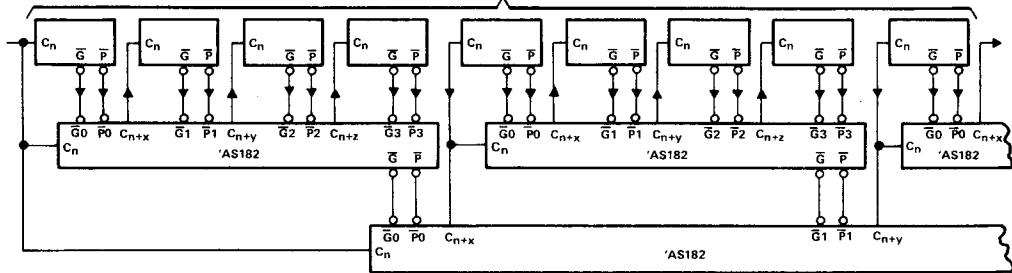

NOTE: Remaining inputs and outputs of 'AS181B or 'AS881A are not shown.

FIGURE 1. THE 'AS182 IN A 64-BIT LOOK-AHEAD CARRY CIRCUIT

2 ALS and AS Circuits