



# NATIONAL HYBRID, INC.

2200 Smithtown Avenue, Ronkonkoma, NY 11779  
(631) 981-2400 Sales FAX 631-981-8888

## Mil-Std-1553/1760 Products NHI-15116 Series +5V Monolithic Dual Transceivers

### Features:

- Fully Compliant, Mil-Std-1553A/B Mil-Std-1760, MacAir Dual Transceivers !!
- Single +5V Supply !!
- 1.5 Watts Maximum Power Dissipation @ 100% Duty Cycle !!
- Output Driver Withstands Short Circuit Fault
- Proprietary Monolithic Design Provides Superior Reliability, with outstanding Thermal Impedance Characteristics !!
- Superior Noise Performance Characteristics

### Description:

The NHI-15116 series of Mil-Std-1553/1760 monolithic dual transceivers are available in 0.800" x .600" 24 pin flatpack package.

Each receiver converts the 1553 bus bi-phase data to complementary RX and RX\_L TTL digital outputs for use by the manchester decoder. The device provides independent receiver enables for each channel.

The transmitters will output bi-phase manchester to the coupling transformer when the TX and TX\_L inputs are driven by complementary TTL digital data. The device provides an independent transmitter inhibit TXINH for each channel.

To reduce the pin count and package size, the transmitter outputs are connected to the receiver inputs internal to the device for each channel. This results in only two connections BUS & BUS\_L to the coupling transformer per channel.

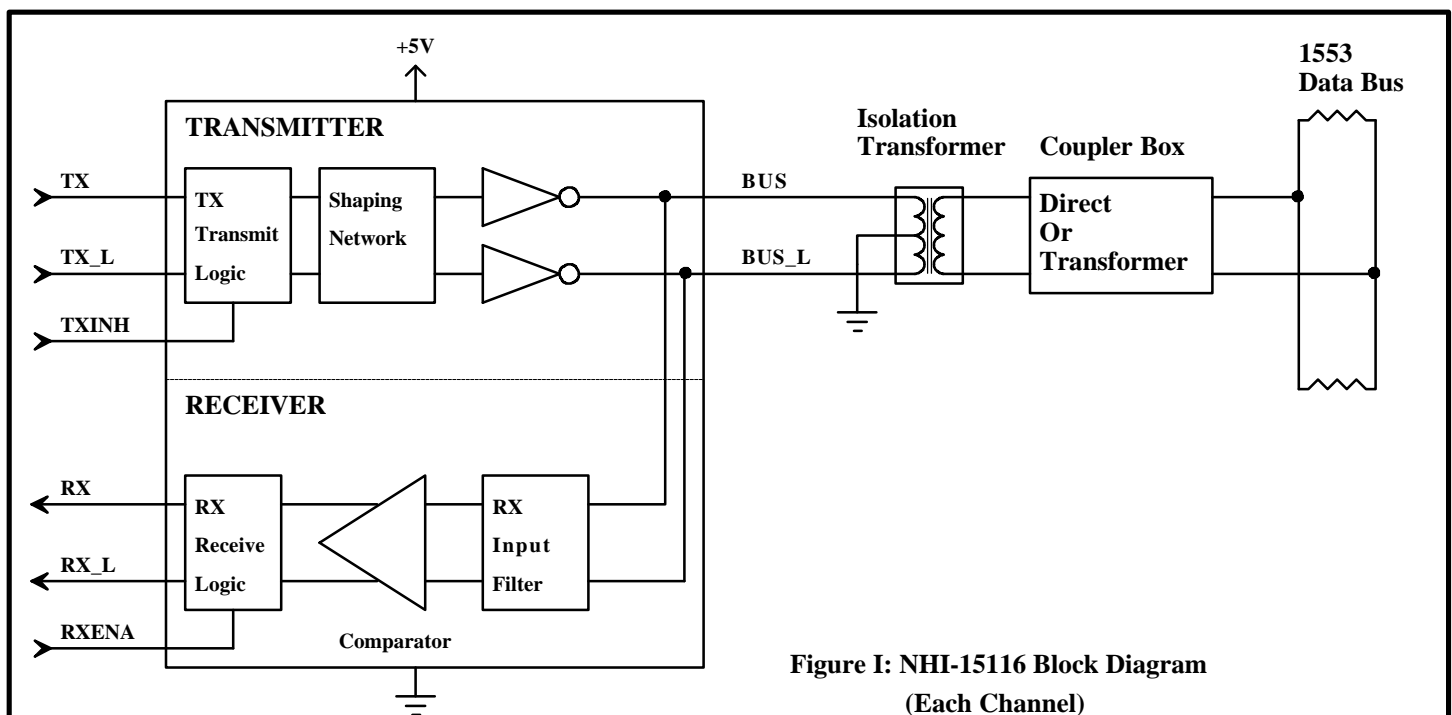

Figure I: NHI-15116 Block Diagram  
(Each Channel)

# NHI-15116 Series

**TABLE I: Electrical Specifications**

Parameter	Condition	Symbol	Min	Typ	Max	Units
<b>POWER SUPPLY REQUIREMENT</b>		Vcc	4.7		5.5	V
<b>TOTAL SUPPLY CURRENT</b>	Vcc=5.0V, Not Transmitting	Icc1		70	80	mA
	Vcc=5.0V, Transmit one channel @ 50% duty cycle	Icc2		320	340	mA
	Vcc=5.0V, Transmit one channel @ 100% duty cycle	Icc3		570	615	mA
<b>POWER DISSIPATION</b>	Vcc=5.0V, Not Transmitting	Pd1			0.4	W
	Vcc=5.0V, Transmit one channel @ 100% duty cycle	Pd2			1.5	W
<b>OPERATING TEMPERATURE</b>	Junction	Tj	-55		165	°C
	Case	Tc	-55		125	°C
	Storage	Ts	-55		165	°C
<b>THERMAL IMPEDANCE</b>	Junction to Case	θjc			4	°C/W
<b>LOGIC I/O</b>						
RXENA_A, TXA, TXA_L, TXINH_A, RXENA_B, TXB, TXB_L, TXINH_B	Vcc= 5.5V, Vil= 0.0V	Iil			-0.4	mA
	Vcc= 4.7v, Vih= 2.7V	Iih			20	uA
RXA, RXA_L, RXB, RXB_L	Vcc= 5.5V, Iol= -4mA	Vol			0.4	V
	Vcc= 4.7v, Ioh= 400 uA	Voh	2.7			V
<b>RECEIVER</b>						
Input Resistance	Differential	Rin	20			k Ω
Input Capacitance	Differential	Cin			5	pF
Common Mode Rejection Ratio		CMRR	40			dB
Input Level	Differential	Vin			40	Vpp
<b>TRANSMITTER</b>						
Output Voltage	Across 140 Ω load	V <sub>out</sub>	29		36	Vpp
Rise/Fall Time	10% to 90% of peak to peak output	t <sub>r</sub> , t <sub>f</sub>	100	150	300	nS
Output DynamicOffset Voltage	Across 35 Ω load	Vdyn	-90		90	mV
Output Noise	Differential	Vnpp			10	mVpp
Output Resistance	Differential, not transmitting	Rout	10			kΩ

Note: Typical receiver threshold is 0.9v pk-pk, reference to the bus.

# NHI-15116 Series

**Table II: Pin Functions**

Pin#	Function	Pin#	Function
1	BUS_A	24	TXA_L
2	BUS_A_L	23	TXA
3	GND_A	22	TXINH_A
4	RXA	21	GND_A
5	RXENA_A	20	+5V_A
6	RXA_L	19	GND_A
7	BUS_B	18	TXB_L
8	BUS_B_L	17	TX_B
9	GND_B	16	TXINH_B
10	RXB	15	GND_B
11	RXENA_B	14	+5V_B
12	RXB_L	13	GND_B

## Transformer Requirements:

The NHI-15116 series requires a transformer with a turns ratio 1:2.5 for Direct Coupling, and a turns ratio of 1:1.79 for Transformer Coupling to the Mil-Std-1553 Bus. Technitrol part number Q1553-45 or equivalent is recommended. The center tap on the transceiver side of the isolation transformer must be grounded.

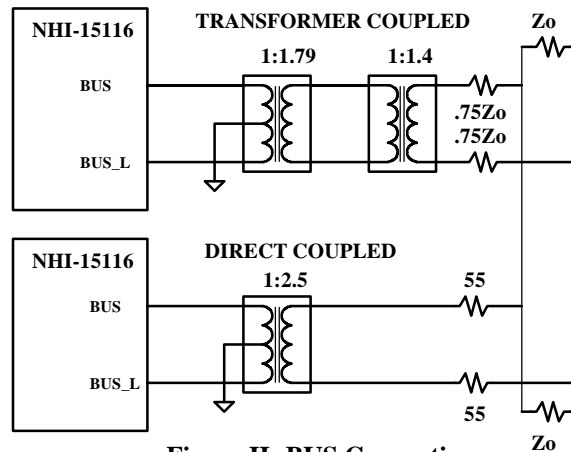

**Figure II: BUS Connections**

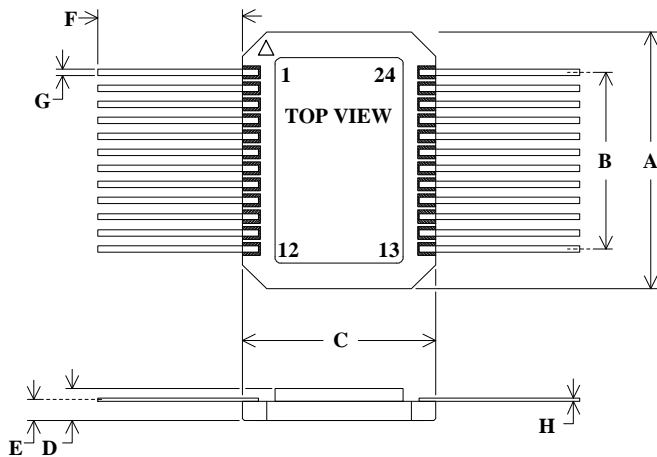

**Figure III: Flatpack Package Detail**

**Table III: Flatpack Dimensions**

DIM	TYP (inches)	TOL (+/- inches)
A	0.800 "	0.008 "
B	11 EQ SP @	0.050 = 0.550 "
C	0.590 "	0.006 "
D	0.090 "	0.008 "
E	0.060 "	0.010 "
F	0.500 "	MIN
G	0.015 "	0.002 "
H	0.010 "	0.002 "

# NHI-15116 Series

## Transmit Waveforms

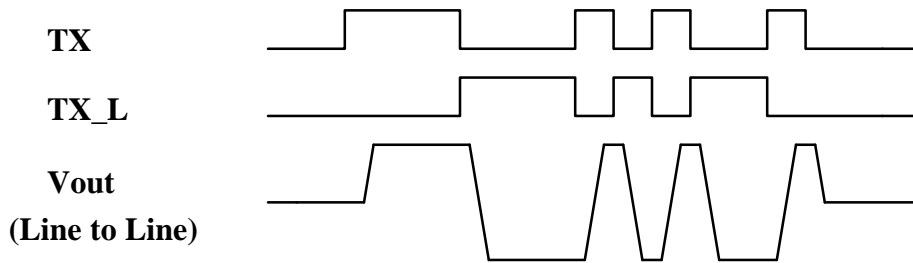

## Transmitter Operation:

A high level input on TXINH will inhibit the transmitter outputs. If the TX & TX\_L transmitter inputs are both high or both low, the transmitter is also inhibited. The output drivers are short circuit protected and the device will "fold back" to decrease power dissipation under this condition until the fault is removed.

## Receive Waveforms

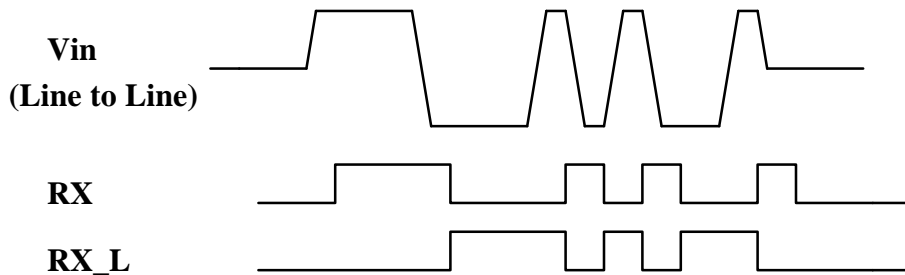

## Receiver Operation:

A low level input on RXENA will disable the receiver outputs RX & RX\_L regardless of bus activity. The receiver output compatibility may be specified as logic 0 or logic 1 when in standby mode.

\*\* See Ordering Information

## Ordering Information:

NHI-15116 FP / 883

Reliability Grade

883 = Fully Compliant with Mil-Std-883

M = Screened to Mil-Std-883, -55 to +125 °C

Blank = Industrial, -40 to +85 °C

Package Style

FP = Flatpack (Figure IV)

Transceiver Type and Decoder Compatibility

116 = Mil-Std-1553, RX & RX\_L, Standby = Logic 0

130 = Mil-Std-1553, RX & RX\_L, Standby = Logic 1

See QML-38534 for NHI's Manufacturer Qualification Under Mil-PRF-38534