



# System Overview

## HDSL System with Bt8921

The Bt8921 HDSL Analog Front End (AFE) is an integral component of Brooktree's HDSL chipset. System performance of the chipset allows 2-pair T1, 2-pair E1, and 3-pair E1 transmission. The major building blocks of a typical HDSL T1/E1 terminal are shown in Figure 1.

Figure 1. HDSL T1/E1 Terminal

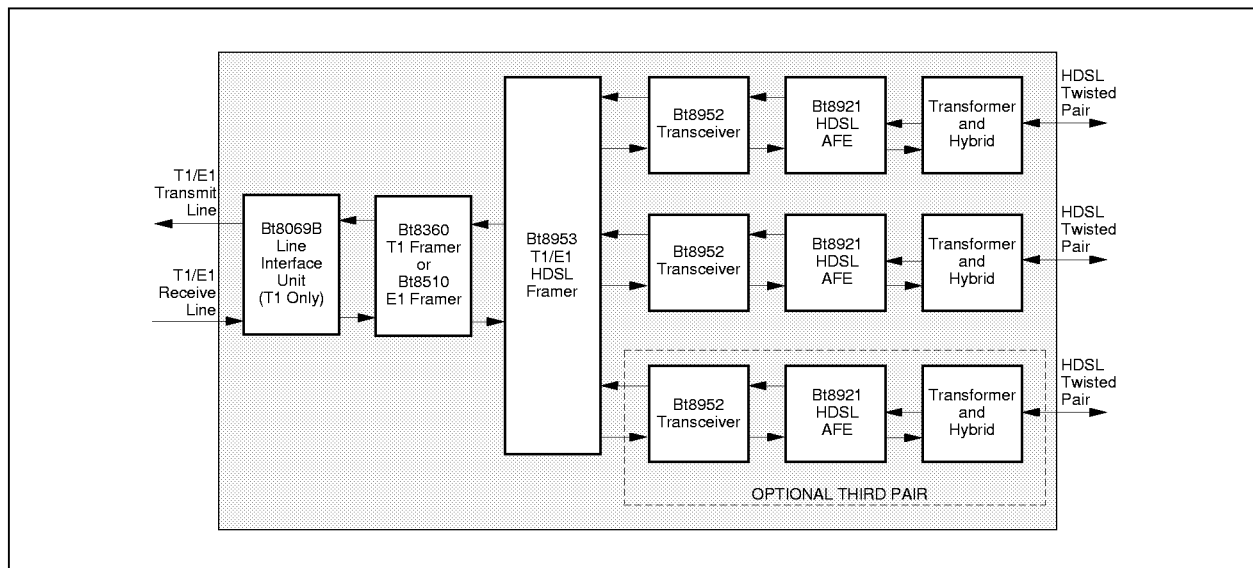

The Bt8921 provides the interface between the analog and digital domains in the HDSL system. It performs all the active amplification, filtering, analog-to-digital, and digital-to-analog conversion needed to connect the Bt8952 transceiver to an HDSL line transformer. The Bt8952 transceiver performs adaptive echo cancellation, equalization, symbol quantization, and clock recovery. The Bt8953 channel unit is responsible for HDSL framing and overhead functions as well as multiplexing/demultiplexing of the two or three HDSL data streams to/from the primary-rate T1/E1 data stream.

 *Insert blank page here*



# Product Description

## Performance Summary

A summary of the Bt8921 performance characteristics is listed below in Table 1, Performance Summary.

**Table 1. Performance Summary (1 of 3)**

	Parameter	Comments	Min	Typ	Max	Units
Receive Channel	Receive Clock Rate, $f_{rx}$ <sup>(1)</sup>	48 x TXCLK (TXCLK = Symbol rate)	TBD		28.032	MHz
	T1 Mode			18.816		MHz
	E1 Mode			28.032		MHz
	Analog Inputs	Differential				
	Hybrid Tip (RXHYB+)	G = +1				
	Hybrid Ring (RXHYB-)	G = -1				
	Line Tip (RXLINE+)	G = +1				
	Line Ring (RXLINE-)	G = -1				
	Input Voltage Range <sup>(2)</sup>	Balanced Differential	-3.5		+3.5	V
	Input Impedance	All Inputs		40		k $\Omega$
	Input Capacitance			TBD		
	Input Matching				$\pm 2$	%
	Common Mode Voltage			Vdd/2		
	A/D Converter					
	Resolution	No Missing Codes	13			Bits
	Integral Linearity <sup>(3)</sup>	13-bit LSB			$\pm 1$	LSB
	Differential Linearity <sup>(3)</sup>				$\pm 0.8$	LSB
	Programmable Gain	Four gains between 0 dB and +9 dB	0		+9	dB
	Gain + Offset Error			5		%FSR <sup>(4)</sup>
	Output Data Rate	$f_{rx}/48$				
T1 mode			392		kHz	
E1 mode			584		kHz	
SINAD <sup>(5)</sup>		70			dB	



## Performance Summary

Table 1. Performance Summary (2 of 3)

	Parameter	Comments	Min	Typ	Max	Units
Transmit Channel	Transmit Clock Rate, $f_{TX}$ :	TXCLK Input	TBD		584	kHz
	T1 Mode			392		kHz
	E1 Mode			584		kHz
	T1 Mode Operation: <sup>(6, 7)</sup>					
	Pulse Template <sup>(8)</sup>	See Figure 2				
	Power Spectral Density <sup>(9)</sup>	See Figure 3				
	-3 dB Point			196		kHz
	Average Power <sup>(3, 9)</sup>	0 to 784 kHz, $R_L = 65 \Omega$	13		14	dBm
	E1 Mode Operation: <sup>(6, 10)</sup>					
	Pulse Template	See Figure 2				
Power Spectral Density <sup>(9)</sup>	See Figure 3					
-3 dB Point			292		kHz	
Average Power <sup>(3, 9)</sup>	0 to 1.168 MHz, $R_L = 65 \Omega$	13		14	dBm	
Output Voltage Range	Balanced Differential, $R_L = 28 \Omega$	$\pm 3.1$	$\pm 3.3$	$\pm 3.5$	V	
Output Current		125			mA	
Common-Mode Voltage			$V_{DD}/2$		V	
Output Impedance <sup>(3)</sup>	DC to 1 MHz			2	$\Omega$	
Linearity <sup>(11)</sup>	At Output Symbol Peak			0.012	%FSR <sup>(4)</sup>	
Harmonic Distortion	3 kHz, 3.4 Volt Peak Sine Wave Output, $R_L = 28 \Omega$			-65	dB	
HDSL Transformer Ratio	T1 or E1 Rates	1:2				
PLL Frequency Change Range			100		ppm	
Digital Interface <sup>(3)</sup>	Input Levels	HCMOS and TTL Compatible				
	Output Levels	HCMOS Drive Compatible	10			Loads
	RX Interface:					
	$t_{rx1}$	RXDATA to RXSYNC Setup Time	50			ns
	$t_{rx2}$	RXDATA to RXSYNC Hold Time	10			ns
	Tx Interface:					
	$t_{tx1}$	TXCLK Period	1.7			$\mu$ s
$t_{tx2}$	TXCLK Pulse Width	50			ns	
$t_{tx3}$	TXCLK to TXDATA Edge Allowable Error	0		200	ns	
Power	Power Supply Voltage	Specification		5		V
	Power Supply Voltage	Operating Range	4.75		5.25	V
	Power Dissipation	$V = +5$ VDC, $R_L = 65 \Omega$		300		mW
	PSRR	Power Supply Rejection	65			dB



Table 1. Performance Summary (3 of 3)

	Parameter	Comments	Min	Typ	Max	Units
Package	Number of Pins	Plastic, SSOP		48		Pins
Temperature Range	Operating <sup>(3)</sup>		-40		+85	°C

Notes: (1). Receive clock is synthesized on chip from TXCLK.  
 (2). Input voltage range when Variable Gain Amplifier (VGA) gain equals 0 dB. Input voltage range is reduced proportionally as VGA gain is increased.  
 (3). Guaranteed by design and characterization.  
 (4). FSR is Full Scale Range.  
 (5). Signal to noise plus distortion; production tested with full-scale 8 kHz and 250 kHz input @ 584 kHz output data rate.  
 (6). Measured on line side of HDSL transformer loaded with 135  $\Omega$ , unless otherwise specified.  
 (7). Bellcore TA-NWT-001210 and ANSI T1E1.4/94-006 compliant.  
 (8). Per ANSI T1E1.4/96-006 contribution T1E1.4/92-168.  
 (9). Measured with a pseudo-random code sequence of HDSL pulses.  
 (10). ETSI RTR/TM-03036 and ETSI ETR152 compliant.  
 (11). Linearity guaranteed by measuring voltage levels of each of the four symbol outputs.



**Typical Performance Curves at Output of HDSL Pulse Transformer**

The curves shown below are measured at the line output of the HDSL transformer. Typical at 25°C and  $V_{supply} = +5\text{ V}$ , unless otherwise specified. See Figure 2, Table 2, and Figure 3.

**Figure 2. Transmitted Pulse Template Measured at HDSL Transformer Output**

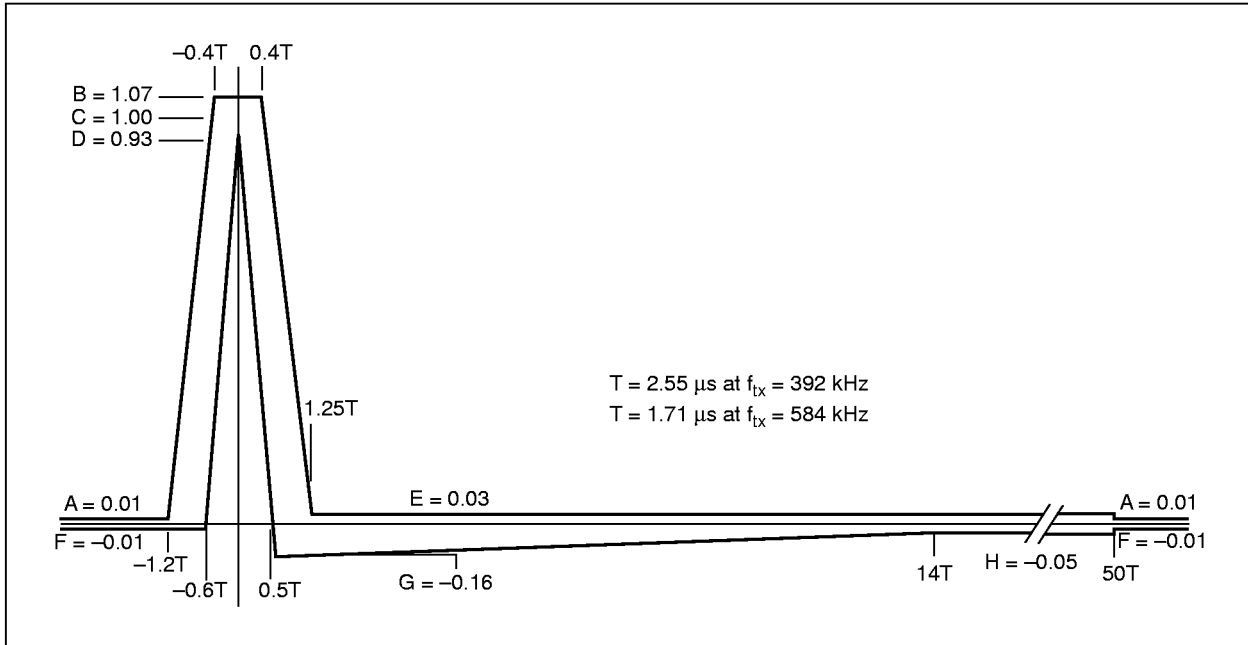
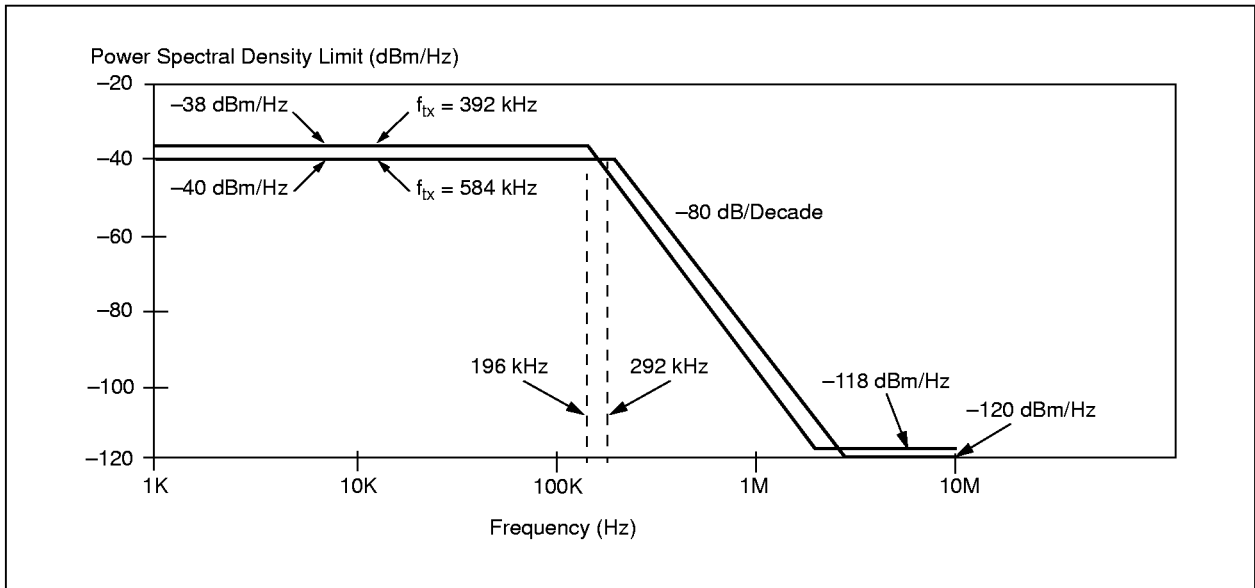

**Table 2. Transmitted Pulse Template Measured at HDSL Transformer Output**

Normalized Level		Quaternary Symbols			
		+3	+1	-1	-3
A	0.01	0.0264	0.0088	-0.0088	-0.0264
B	1.07	2.8248	0.9416	-0.9416	-2.8248
C	1.00	2.6400	0.8800	-0.8800	-2.6400
D	0.93	2.4552	0.8184	-0.8184	-2.4552
E	0.03	0.0792	0.0264	-0.0264	-0.0792
F	-0.01	-0.0264	-0.0088	0.0088	0.0264
G	-0.16	-0.4224	-0.1408	0.1408	0.4224
H	-0.05	-0.1320	-0.0440	0.0440	0.1320



Figure 3. Upper Bound of Power Spectral Density Measured at Output of HDSL Transformer





## Pin Descriptions

Pin descriptions, numbers, names and types are listed in Table 3. A pinout diagram of the Bt8921 is illustrated in Figure 4.

**Table 3. Bt8921 Pinout (1 of 2)**

Pin #	Pin Name	Type	Description
1	GNDP	Ground	Analog ground for PLL
2	VSPP	Power	Analog supply (+5 V) for PLL
3	TXCLK	Input	Symbol clock (QCLK from Bt8952) (392 kHz for T1, 584 kHz for E1)
4	TXDATA-	Input	XMITB line from Bt8952
5	TXDATA+	Input	XMIT line from Bt8952
6	RXDATA0	Output	ADC output bit 0 (RCV 2 from Bt8952)
7	RXDATA1	Output	ADC output bit 1 (RCV 3 from Bt8952)
8	RXDATA2	Output	ADC output bit 2 (RCV 4 from Bt8952)
9	RXDATA3	Output	ADC output bit 3 (RCV 5 from Bt8952)
10	RXDATA4	Output	ADC output bit 4 (RCV 6 from Bt8952)
11	RXDATA5	Output	ADC output bit 5 (RCV 7 from Bt8952)
12	GNDD	Ground	Digital ground
13	VSPD	Power	Digital supply (+5 V)
14	RXDATA6	Output	ADC output bit 6 (RCV 8 from Bt8952)
15	RXDATA7	Output	ADC output bit 7 (RCV 9 from Bt8952)
16	RXDATA8	Output	ADC output bit 8 (RCV 10 from Bt8952)
17	RXDATA9	Output	ADC output bit 9 (RCV 11 from Bt8952)
18	RXDATA10	Output	ADC output bit 10 (RCV 12 from Bt8952)
19	RXDATA11	Output	ADC output bit 11 (RCV 13 from Bt8952)
20	RXDATA12	Output	ADC output bit 12 (RCV 14 from Bt8952)
21	RXDATA13	Output	ADC output bit 13 (RCV 15 from Bt8952)
22	N/C	N/C	Connection to Ground recommended
23	RXSYNC	Input	A/D sync signal (RCVCLK) (392 kHz for T1, 584 kHz for E1)
24	RXGAIN0	Input	Receive gain control bit 0 (AGAIN0 from Bt8952)
25	RXGAIN1	Input	Receive gain control bit 1 (AGAIN1 from Bt8952)
26	RXLOOP	Input	Loopback control signal
27	VSPA	Power	Analog supply (+5 V)

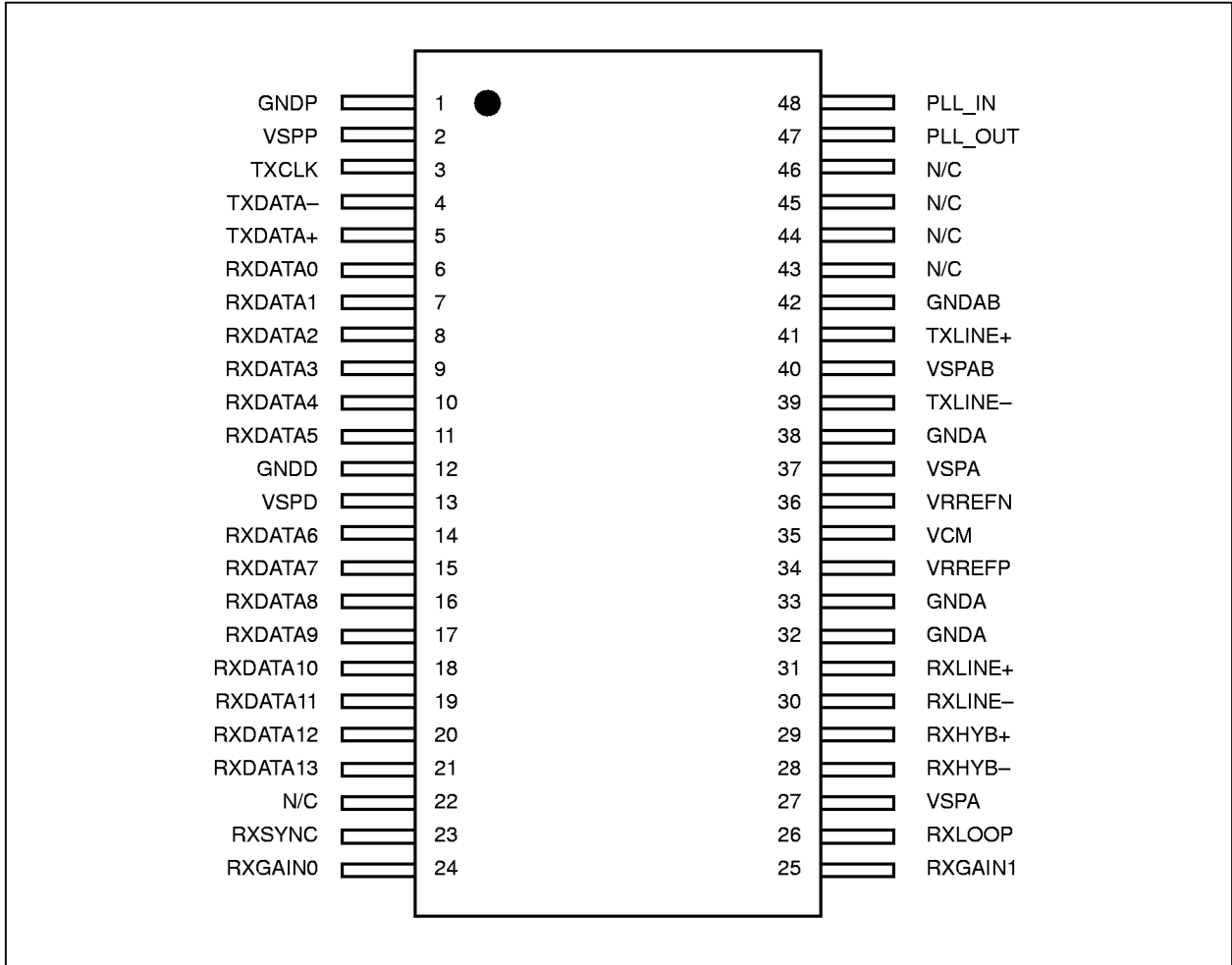

Table 3. Bt8921 Pinout (2 of 2)

Pin #	Pin Name	Type	Description
28	RXHYB-	Input	Negative input from hybrid network
29	RXHYB+	Input	Positive input from hybrid network
30	RXLINE-	Input	Negative line input
31	RXLINE+	Input	Positive line input
32	GND A	Ground	Analog ground
33	GND A	Ground	Analog ground
34	VRREFP	Output	Positive reference output
35	VCM	Output	Common mode voltage (buffered)
36	VRREFN	Output	Negative reference output
37	VSPA	Power	Analog supply (+5 Volts)
38	GND A	Ground	Analog ground
39	TXLINE-	Output	Negative line output
40	VSPAB	Power	Output buffer supply (+5 Volts)
41	TXLINE+	Output	Positive line output
42	GNDAB	Ground	Output buffer ground
43	N/C	N/C	Connection to Ground recommended
44	N/C	N/C	Connection to Ground recommended
45	N/C	N/C	Connection to Ground recommended
46	N/C	N/C	Connection to Ground recommended
47	PLL_OUT	Output	PLL filter output
48	PLL_IN	Input	PLL filter input



Figure 4. Bt8921 48-pin Shrink Small Outline Package (SSOP) Pinout Diagram





# Functional Description

---

## ***Receive Channel Variable Gain Amplifier***

The gain of the amplifier at the input of the receive channel is set by two gain control pins, RXGAIN1 and RXGAIN0. The resulting gain between 0 dB and +9 dB is shown in Table 4.

***Table 4. Receive Channel Variable Gain Settings***

<b>RXGAIN1</b>	<b>RXGAIN0</b>	<b>Gain</b>
0	0	0 dB
0	1	3 dB
1	0	6 dB
1	1	9 dB

## ***Receive Data Coding***

The data from the receive channel A/D converter is coded in offset binary as listed in Table 5.

***Table 5. A/D Converter Output Format***

<b>Analog Input</b>	<b>Output Code (RXDATA[13:0])</b>
Positive Full Scale	11111111111111
Negative Full Scale	00000000000000



## ***RXLOOP Input***

RXLOOP is the loopback control signal. When enabled, the RXLINE+ and RXLINE- inputs are disconnected from the Bt8921. The RXHYB+ and RXHYB- inputs remain connected. Loopback is enabled by applying a positive signal (Logic 1) to RXLOOP.

## ***Echo Cancellation***

The RXHYB input is designed to be subtracted from the RXLINE input for first order echo cancellation. To accomplish this, note that the RXLINE input is connected to the same polarity signal at the transformer (+ to + and - to -) while the RXHYB input is connected to opposite polarity through the compromise hybrid (- to + and + to -) as shown in the Bt8921 Hybrid Configuration Diagram, Figure 9.



# Electrical and Mechanical Specifications

## Electrical Specifications

Stresses above those listed in Table 6 may cause permanent damage to the device. This is a stress rating only, and functional operation of the device at these or any other conditions above those indicated in the other sections of this document is not implied. Exposure to absolute maximum rating conditions for extended periods may affect device reliability.

**Table 6. Absolute Maximum Ratings**

Parameter	Value
Power Supply Voltage	TBD VDC
Differential Input Voltage	TBD V
Storage Temperature Range	-40°C to +125°C
Lead Temperature (Soldering)	+260°C
Output Short Circuit to Ground (+25°C)	Continuous
Junction Temperature ( $T_J$ )	+150°C

**Figure 5. Receive Channel Timing**

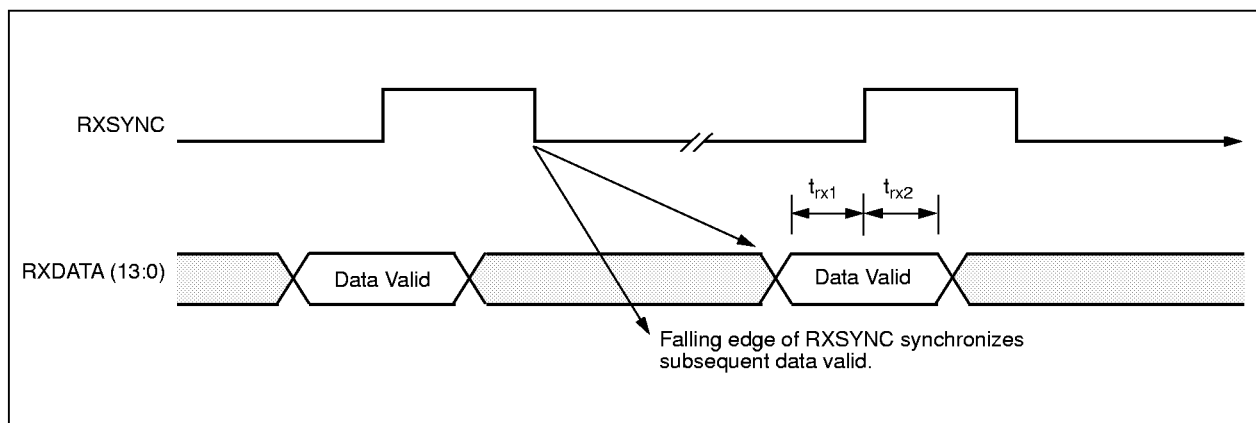
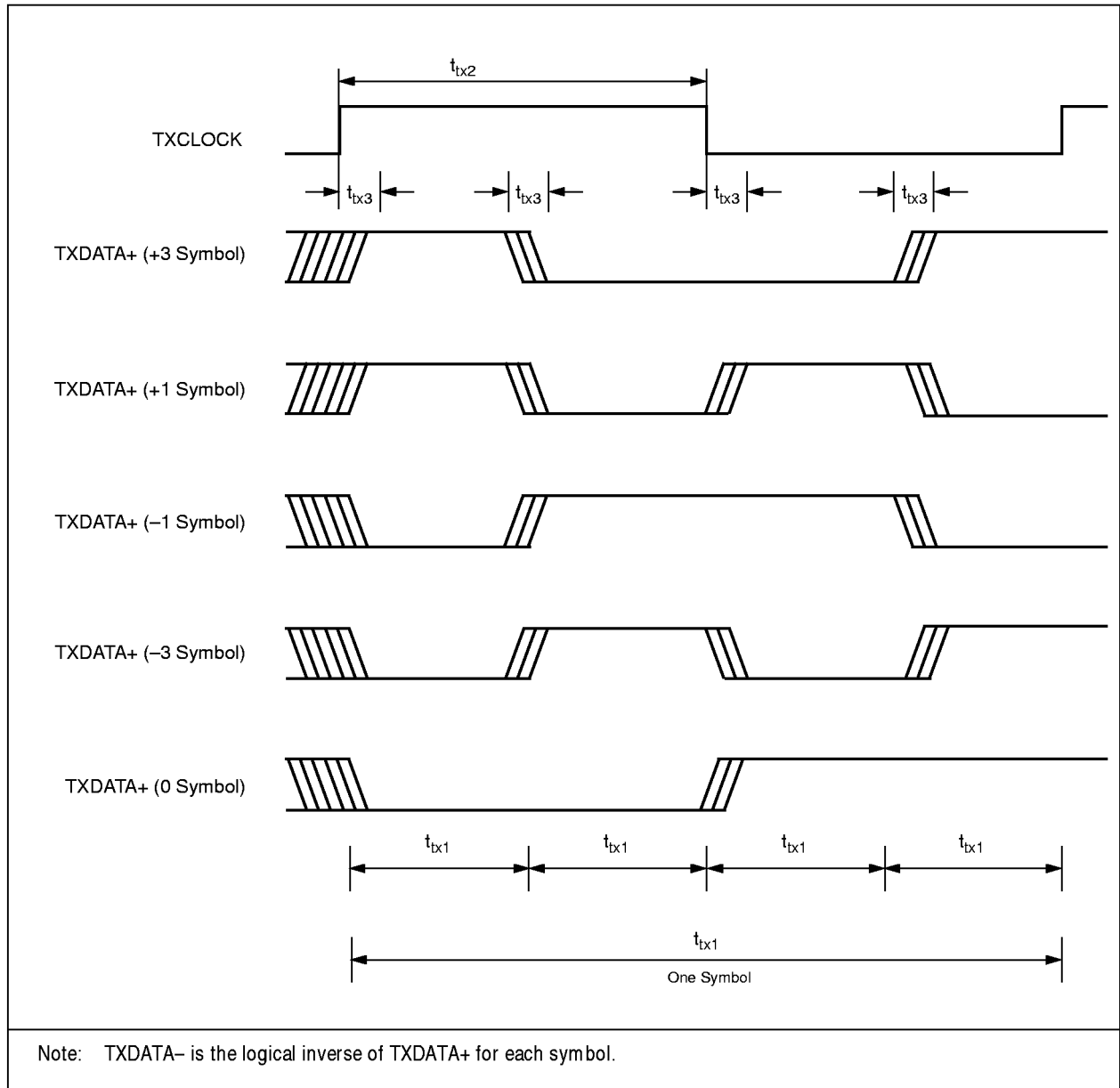



Figure 6. Transmit Channel Timing





# Mechanical Specifications

Figure 7. 48-Pin Shrink Small Outline Package (SSOP)

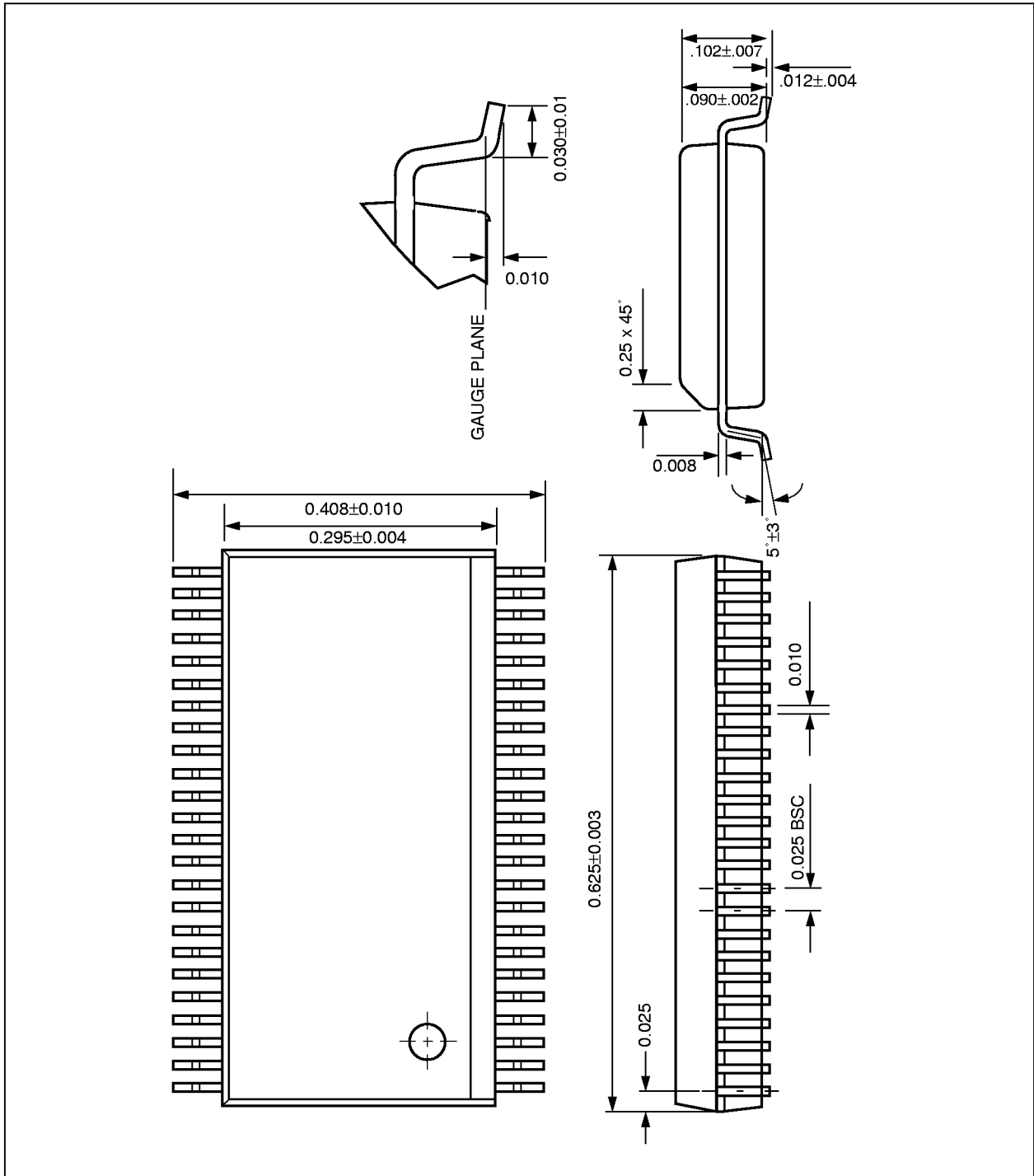

 *Insert blank page here*



# Application Information

## Basic Bt8921 Interconnection Diagram

The basic interconnection diagrams for the Bt8921 are shown in Figures 8 and 9. Recommended component values are listed in Table 7.

Figure 8. Basic Bt8921 Interconnection Diagram

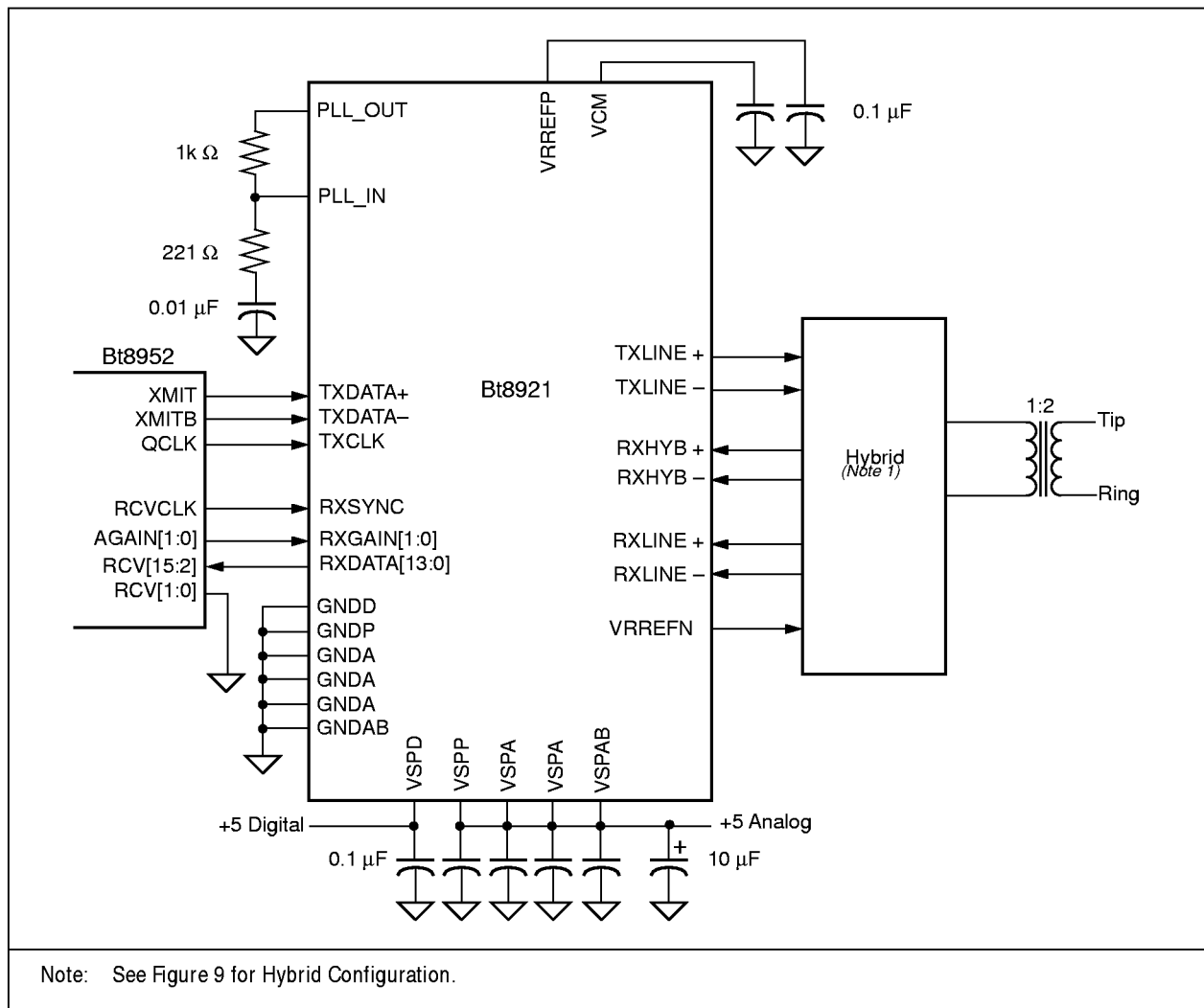
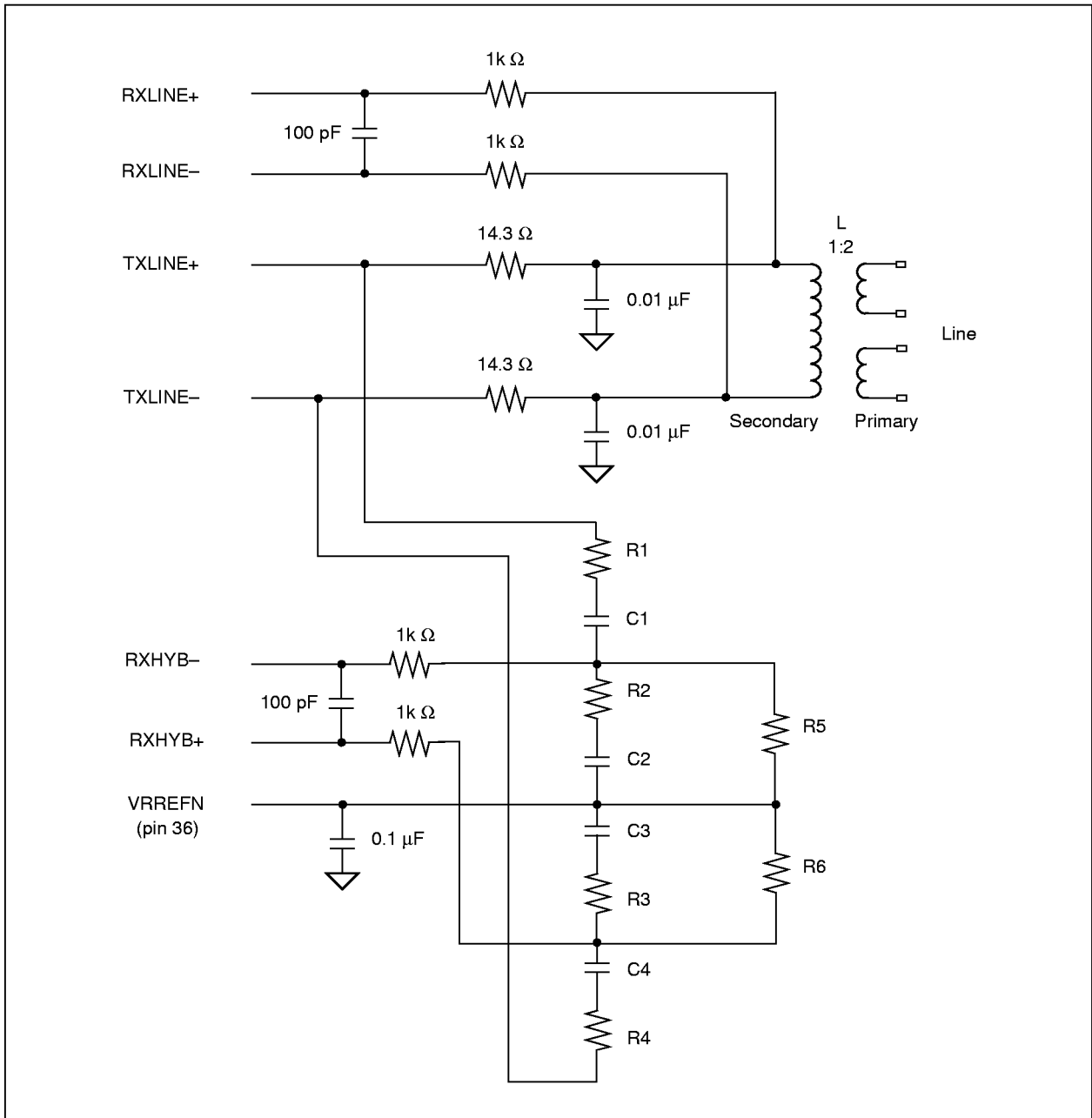



Figure 9. Bt8921 Hybrid Configuration



**Table 7. Hybrid Configuration Component Values**

Hybrid Component	Data Rate	
	1168 kbps	784 kbps
R1, R4	1.3 k $\Omega$	1.3 k $\Omega$
C1, C4	3 nF	4.7 nF
R2, R3	1k $\Omega$	787 $\Omega$
C2, C3	1 nF	1.8 nF
R5, R6	6 k $\Omega$	6 k $\Omega$
L (OCL)	2 mH	3 mH