

VHF~UHF BAND LOW NOISE AMPLIFIER APPLICATIONS.

- Low Noise Figure, High Gain.
- $NF = 1.8dB$, $|S_{21e}|^2 = 7.5dB$ ($f = 2GHz$)

MAXIMUM RATINGS ($T_a = 25^\circ C$)

CHARACTERISTIC	SYMBOL	RATING	UNIT
Collector-Base Voltage	V_{CB0}	20	V
Collector-Emitter Voltage	V_{CEO}	10	V
Emitter-Base Voltage	V_{EBO}	1.5	V
Base Current	I_B	7	mA
Collector Current	I_C	15	mA
Collector Power Dissipation	P_C	100	mW
Junction Temperature	T_j	125	$^\circ C$
Storage Temperature Range	T_{stg}	-55~125	$^\circ C$

MARKING

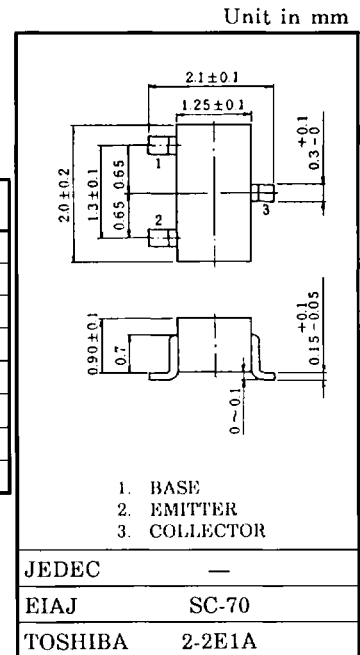
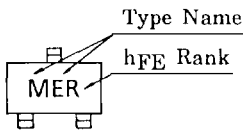

Weight : 0.006g

MICROWAVE CHARACTERISTICS ($T_a = 25^\circ C$)

CHARACTERISTIC	SYMBOL	TEST CONDITION	MIN.	TYP.	MAX.	UNIT
Transition Frequency	f_T	$V_{CE} = 6V, I_C = 7mA$	7	10	—	GHz
Insertion Gain	$ S_{21e} ^2$ (1)	$V_{CE} = 6V, I_C = 7mA, f = 1GHz$	—	13	—	dB
	$ S_{21e} ^2$ (2)	$V_{CE} = 6V, I_C = 7mA, f = 2GHz$	4.5	7.5	—	
Noise Figure	NF (1)	$V_{CE} = 6V, I_C = 3mA, f = 1GHz$	—	1.4	—	dB
	NF (2)	$V_{CE} = 6V, I_C = 3mA, f = 2GHz$	—	1.8	3.0	

ELECTRICAL CHARACTERISTICS ($T_a = 25^\circ C$)

CHARACTERISTIC	SYMBOL	TEST CONDITION	MIN.	TYP.	MAX.	UNIT
Collector Cut-off Current	I_{CB0}	$V_{CB} = 10V, I_E = 0$	—	—	1	μA
Emitter Cut-off Current	I_{EBO}	$V_{EB} = 1V, I_C = 0$	—	—	1	μA
DC Current Gain	h_{FE} ^{Note}	$V_{CE} = 6V, I_C = 7mA$	50	—	160	—
Output Capacitance	C_{ob}	$V_{CB} = 10V, I_E = 0, f = 1MHz$	—	0.5	—	pF
Reverse Transfer Capacitance	C_{re}	(Note)	—	0.4	0.85	pF

Note : C_{re} is measured by 3 terminal method with capacitance bridge.

Note : h_{FE} Classification R : 50~100, O : 80~160

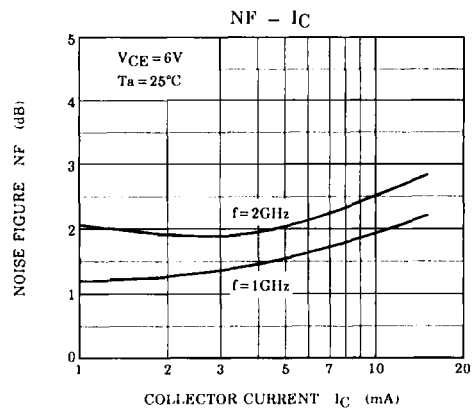
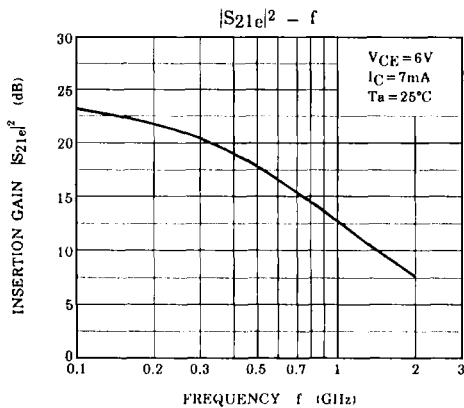
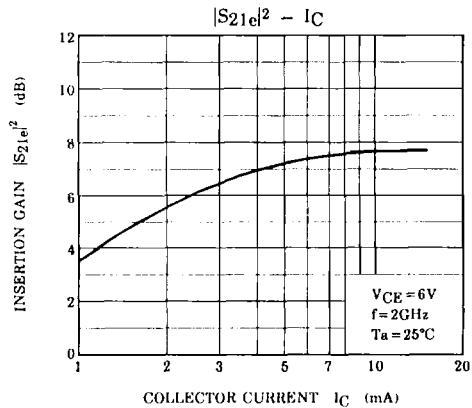
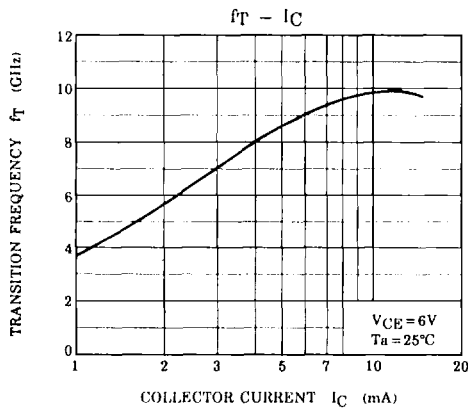
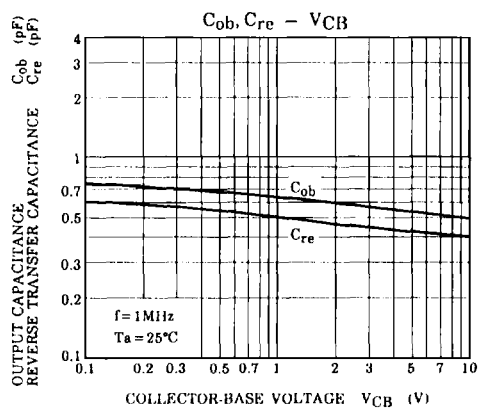
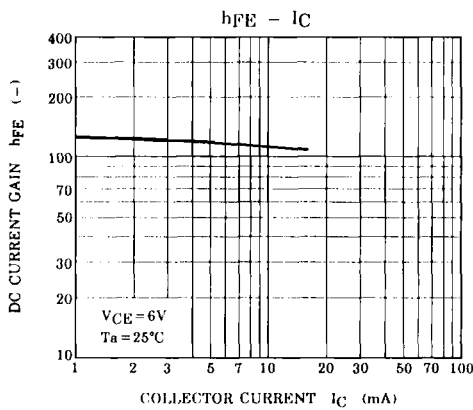

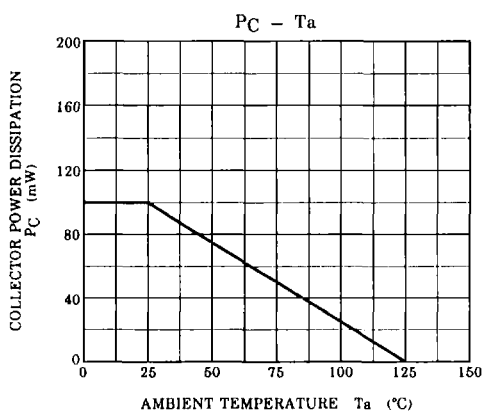
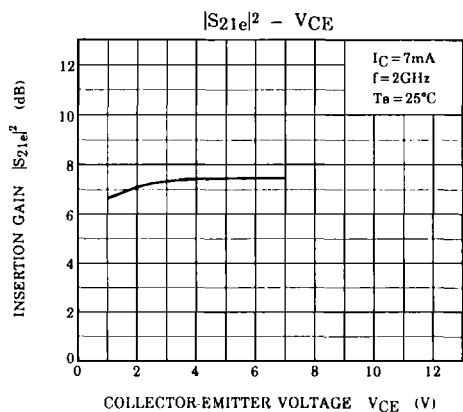

S-Parameter $Z_O = 50\Omega$, $T_a = 25^\circ\text{C}$
 $V_{CE} = 6\text{V}$, $I_C = 3\text{mA}$

frequency (MHz)	S11		S21		S12		S22	
	Mag.	Ang.	Mag.	Ang.	Mag.	Ang.	Mag.	Ang.
200	0.835	-26.1	7.069	150.4	0.046	71.0	0.899	-19.3
400	0.665	-46.5	5.948	130.4	0.076	60.5	0.745	-30.3
600	0.501	-62.7	5.021	115.2	0.095	55.7	0.630	-35.9
800	0.386	-74.3	4.173	104.3	0.111	53.7	0.552	-38.5
1000	0.297	-83.7	3.592	95.6	0.124	53.2	0.500	-39.9
1200	0.226	-92.7	3.140	88.5	0.137	53.6	0.465	-41.1
1400	0.175	-101.9	2.808	82.3	0.152	54.1	0.442	-42.2
1600	0.130	-113.4	2.514	76.6	0.165	54.2	0.421	-43.8
1800	0.103	-128.0	2.293	71.7	0.179	53.9	0.405	-45.7
2000	0.081	-147.4	2.114	67.3	0.193	54.8	0.388	-47.4

$V_{CE} = 6\text{V}$, $I_C = 7\text{mA}$

frequency (MHz)	S11		S21		S12		S22	
	Mag.	Ang.	Mag.	Ang.	Mag.	Ang.	Mag.	Ang.
200	0.668	-40.0	12.306	138.9	0.040	67.3	0.786	-27.0
400	0.427	-64.4	8.852	116.1	0.061	61.6	0.579	-35.0
600	0.280	-79.5	6.591	102.9	0.078	61.8	0.476	-35.9
800	0.193	-89.7	5.191	94.3	0.096	62.5	0.420	-35.0
1000	0.134	-99.3	4.288	87.8	0.112	63.2	0.390	-34.2
1200	0.088	-112.3	3.661	81.9	0.130	63.8	0.374	-34.0
1400	0.056	-129.8	3.232	76.9	0.150	63.4	0.366	-34.8
1600	0.035	-169.0	2.857	72.1	0.168	62.5	0.356	-36.6
1800	0.040	157.0	2.574	68.1	0.185	61.4	0.347	-39.0
2000	0.054	131.5	2.363	64.3	0.203	61.3	0.338	-40.2

S_{11e}
 V_{CE} = 6V
 I_C = 3mA
 T_a = 25°C
 (UNIT : Ω)

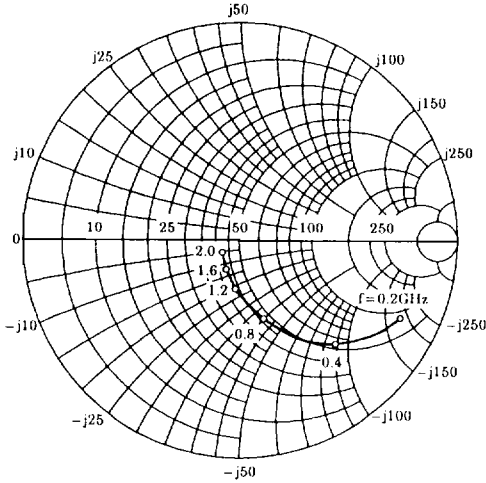

S_{21e}
 V_{CE} = 6V
 I_C = 3mA
 T_a = 25°C

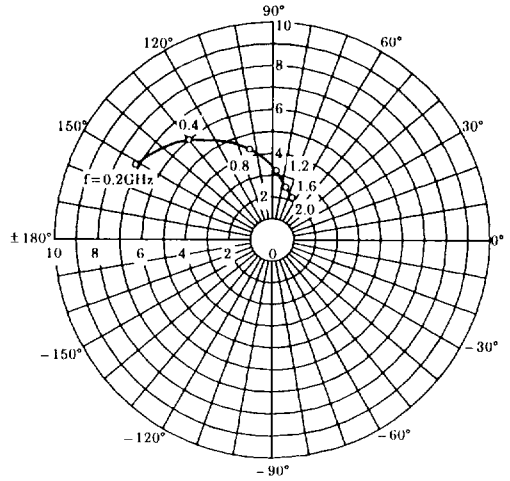

S_{12e}
 V_{CE} = 6V
 I_C = 7mA
 T_a = 25°C

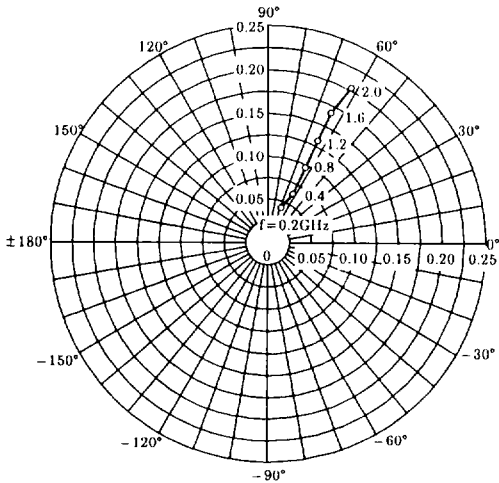

S_{22e}
 V_{CE} = 6V
 I_C = 7mA
 T_a = 25°C
 (UNIT : Ω)

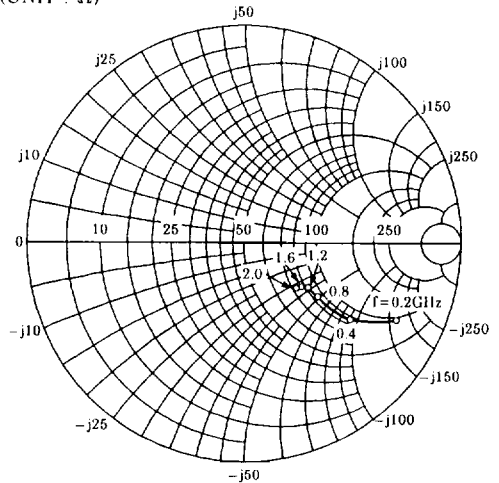

S11e
 VCE = 6V
 IC = 7mA
 Ta = 25°C
 (UNIT : Ω)

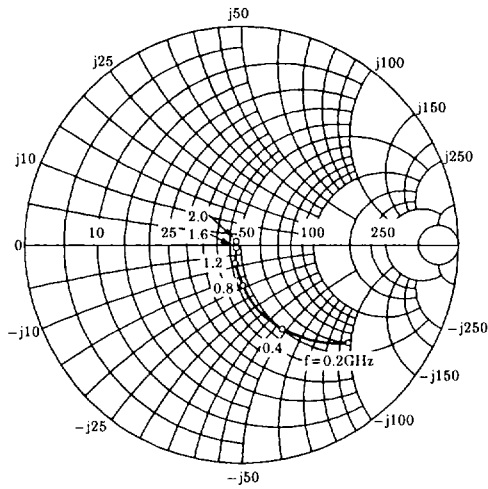

S21e
 VCE = 6V
 IC = 7mA
 Ta = 25°C

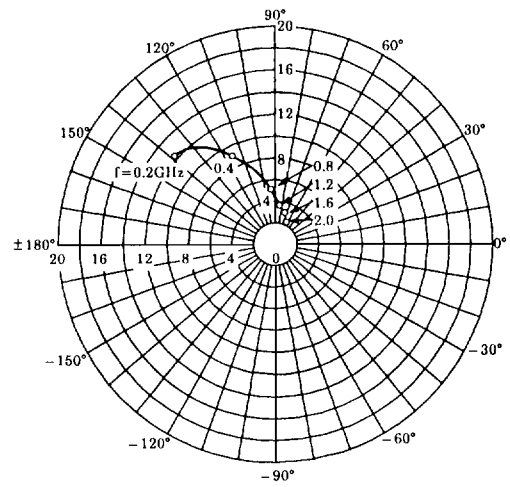

S12e
 VCE = 6V
 IC = 3mA
 Ta = 25°C

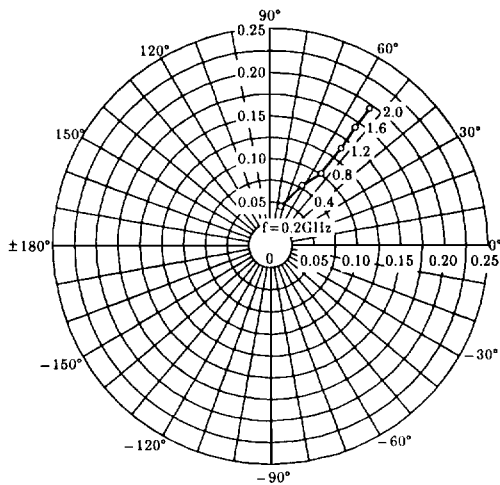

S22e
 VCE = 6V
 IC = 3mA
 Ta = 25°C
 (UNIT : Ω)

