

# 54F/74F381

## 4-Bit Arithmetic Logic Unit

### Description

The 'F381 performs three arithmetic and three logic operations on two 4-bit words, A and B. Two additional select input codes force the function outputs LOW or HIGH. Carry propagate and generate outputs are provided for use with the 'F182 carry lookahead generator for high-speed expansion to longer word lengths. For ripple expansion, refer to the 'F382 ALU data sheet.

- Low Input Loading Minimizes Drive Requirements
- Performs Six Arithmetic and Logic Functions
- Selectable LOW (Clear) and HIGH (Preset) Functions
- Carry Generate and Propagate Outputs for use with Carry Lookahead Generator

Ordering Code: See Section 5

### Logic Symbol

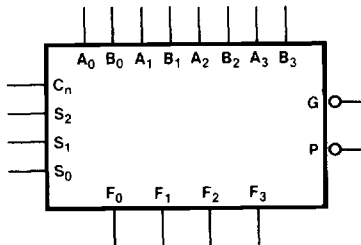

### Connection Diagrams

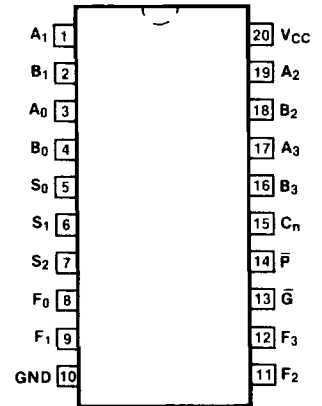

Pin Assignment for DIP and SOIC

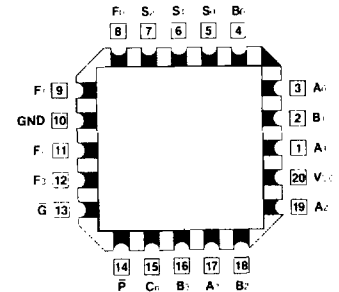

Pin Assignment for LCC and PCC

Input Loading/Fan-Out: See Section 3 for U.L. definitions

| Pin Names                      | Description                         | 54F/74F(U.L.) HIGH/LOW |
|--------------------------------|-------------------------------------|------------------------|
| A <sub>0</sub> -A <sub>3</sub> | A Operand Inputs                    | 0.5/1.50               |
| B <sub>0</sub> -B <sub>3</sub> | B Operand Inputs                    | 0.5/1.50               |
| S <sub>0</sub> -S <sub>2</sub> | Function Select Inputs              | 0.5/0.375              |
| C <sub>n</sub>                 | Carry Input                         | 0.5/1.50               |
| $\bar{G}$                      | Carry Generate Output (Active LOW)  | 25/12.5                |
| $\bar{P}$                      | Carry Propagate Output (Active LOW) | 25/12.5                |
| F <sub>0</sub> -F <sub>3</sub> | Function Outputs                    | 25/12.5                |

**Functional Description**

Signals applied to the Select inputs  $S_0$ - $S_2$  determine the mode of operation, as indicated in the Function Select Table. An extensive listing of input and output levels is shown in the Truth Table. The circuit performs the arithmetic functions for either active HIGH or active LOW operands, with output levels in the same convention. In the Subtract operating modes, it is necessary to force a carry (HIGH for active HIGH operands, LOW for active LOW operands) into the  $C_n$  input of the least significant package.

The Carry Generate ( $\bar{G}$ ) and Carry Propagate ( $\bar{P}$ ) outputs supply input signals to the 'F182 carry lookahead generator for expansion to longer word length, as shown in Figure a. Note that an 'F382 ALU is used for the most significant package. Typical delays for Figure a are given in Figure b.

**Function Select Table**

| Select |       |       | Operation    |
|--------|-------|-------|--------------|
| $S_0$  | $S_1$ | $S_2$ |              |
| L      | L     | L     | Clear        |
| H      | L     | L     | B Minus A    |
| L      | H     | L     | A Minus B    |
| H      | H     | L     | A Plus B     |
| L      | L     | H     | $A \oplus B$ |
| H      | L     | H     | $A + B$      |
| L      | H     | H     | $AB$         |
| H      | H     | H     | Preset       |

H = HIGH Voltage Level  
L = LOW Voltage Level

**Fig. a 16-Bit Lookahead Carry ALU Expansion**

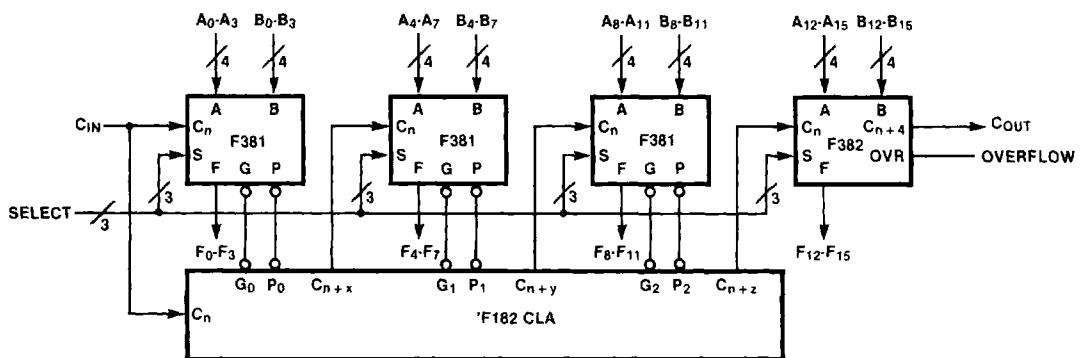

**Fig. b 16-Bit Delay Tabulation**

| PATH SEGMENT                     | TOWARD F | OUTPUT $C_{n+4}, OVR$ |
|----------------------------------|----------|-----------------------|
| $A_i$ or $B_i$ to $\bar{P}$      | 7.2 ns   | 7.2 ns                |
| $\bar{P}_i$ to $C_{n+1}$ ('F182) | 6.2 ns   | 6.2 ns                |
| $C_n$ to F                       | 8.1 ns   | —                     |
| $C_n$ to $C_{n+4}, OVR$          | —        | 8.0 ns                |
| Total Delay                      | 21.5 ns  | 21.4 ns               |

## Logic Diagram

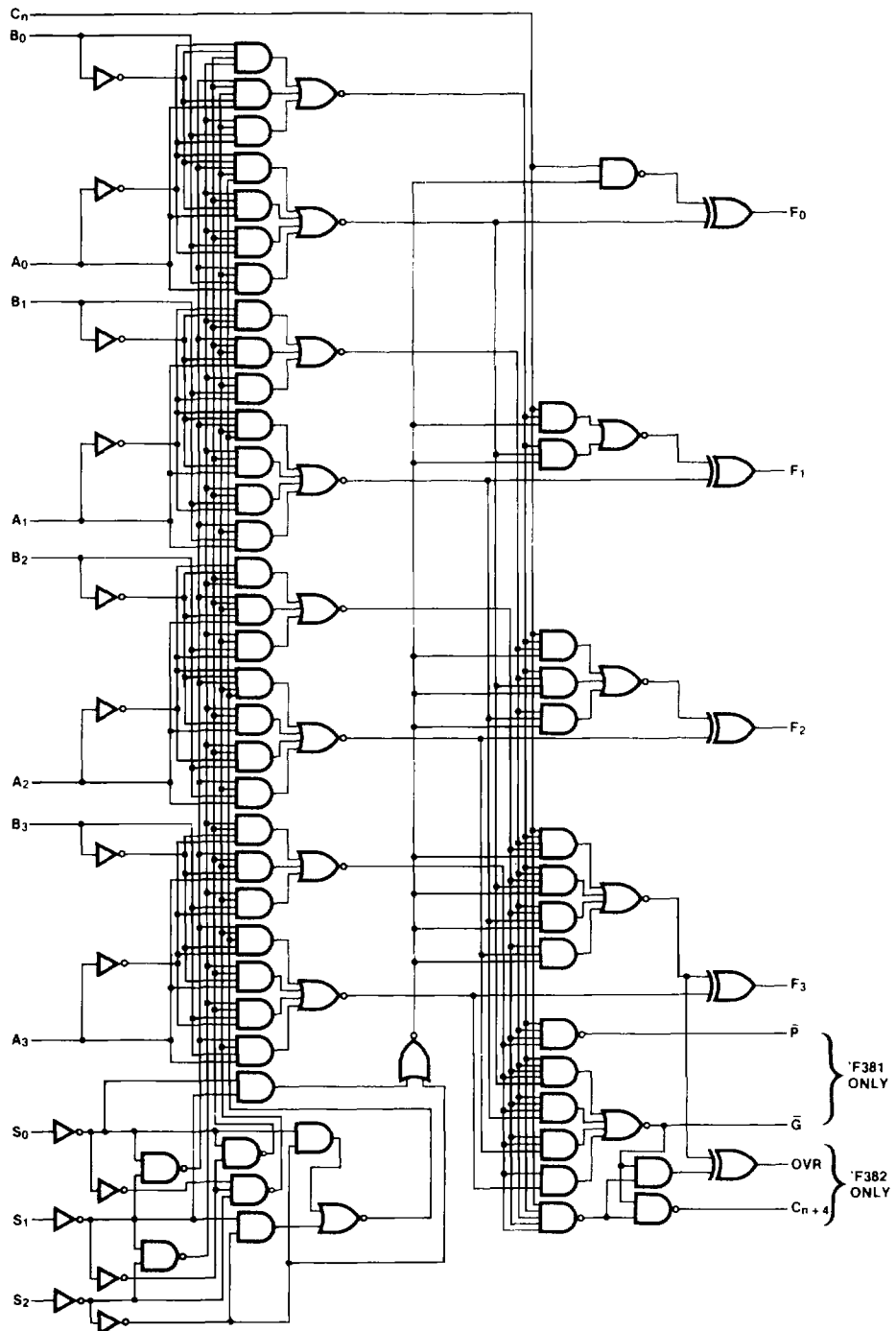

Please note that this diagram is provided only for the understanding of logic operations and should not be used to estimate propagation delays.

Truth Table

| Function  | Inputs         |                |                |                |                |                | Outputs        |                |                |                |           |           |   |
|-----------|----------------|----------------|----------------|----------------|----------------|----------------|----------------|----------------|----------------|----------------|-----------|-----------|---|
|           | S <sub>0</sub> | S <sub>1</sub> | S <sub>2</sub> | C <sub>n</sub> | A <sub>n</sub> | B <sub>n</sub> | F <sub>0</sub> | F <sub>1</sub> | F <sub>2</sub> | F <sub>3</sub> | $\bar{G}$ | $\bar{P}$ |   |
| CLEAR     | 0              | 0              | 0              | X              | X              | X              | 0              | 0              | 0              | 0              | 0         | 0         |   |
| B MINUS A | 1              | 0              | 0              | 0              | 0              | 0              | 1              | 1              | 1              | 1              | 1         | 0         |   |
|           |                |                |                | 0              | 0              | 1              | 0              | 1              | 1              | 1              | 0         | 0         |   |
|           |                |                |                | 0              | 1              | 0              | 0              | 0              | 0              | 0              | 1         | 1         |   |
|           |                |                |                | 0              | 1              | 1              | 1              | 1              | 1              | 1              | 1         | 0         |   |
|           |                |                |                | 1              | 0              | 0              | 0              | 0              | 0              | 0              | 1         | 0         |   |
|           |                |                |                | 1              | 0              | 1              | 1              | 1              | 1              | 1              | 0         | 0         |   |
|           |                |                |                | 1              | 1              | 0              | 1              | 0              | 0              | 1              | 1         | 1         |   |
| A MINUS B | 0              | 1              | 0              | 0              | 0              | 0              | 1              | 1              | 1              | 1              | 1         | 0         |   |
|           |                |                |                | 0              | 0              | 1              | 0              | 0              | 0              | 0              | 1         | 1         |   |
|           |                |                |                | 0              | 1              | 0              | 0              | 1              | 1              | 1              | 0         | 0         |   |
|           |                |                |                | 0              | 1              | 1              | 1              | 1              | 1              | 1              | 1         | 0         |   |
|           |                |                |                | 1              | 0              | 0              | 0              | 0              | 0              | 0              | 1         | 0         |   |
|           |                |                |                | 1              | 0              | 1              | 1              | 0              | 0              | 0              | 1         | 1         |   |
|           |                |                |                | 1              | 1              | 0              | 1              | 1              | 1              | 1              | 0         | 0         |   |
| A PLUS B  | 1              | 1              | 0              | 0              | 0              | 0              | 0              | 0              | 0              | 0              | 1         | 1         |   |
|           |                |                |                | 0              | 0              | 1              | 1              | 1              | 1              | 1              | 1         | 0         |   |
|           |                |                |                | 0              | 1              | 0              | 1              | 1              | 1              | 1              | 1         | 0         |   |
|           |                |                |                | 0              | 1              | 1              | 0              | 1              | 1              | 1              | 0         | 0         |   |
|           |                |                |                | 1              | 0              | 0              | 1              | 0              | 0              | 0              | 1         | 1         |   |
|           |                |                |                | 1              | 0              | 1              | 0              | 0              | 0              | 0              | 1         | 0         |   |
|           |                |                |                | 1              | 1              | 0              | 0              | 0              | 0              | 0              | 1         | 0         |   |
| A ⊕ B     | 0              | 0              | 1              | X              | 0              | 0              | 0              | 0              | 0              | 0              | 1         | 1         |   |
|           |                |                |                | X              | 0              | 1              | 1              | 1              | 1              | 1              | 1         | 1         |   |
|           |                |                |                | X              | 1              | 0              | 1              | 1              | 1              | 1              | 1         | 0         |   |
|           |                |                |                | X              | 1              | 1              | 1              | 0              | 0              | 0              | 0         | 0         |   |
| A + B     | 1              | 0              | 1              | X              | 0              | 0              | 0              | 0              | 0              | 0              | 1         | 1         |   |
|           |                |                |                | X              | 0              | 1              | 1              | 1              | 1              | 1              | 1         | 1         |   |
|           |                |                |                | X              | 1              | 0              | 1              | 1              | 1              | 1              | 1         | 1         |   |
|           |                |                |                | X              | 1              | 1              | 1              | 1              | 1              | 1              | 1         | 0         |   |
| AB        | 0              | 1              | 1              | X              | 0              | 0              | 0              | 0              | 0              | 0              | 0         | 0         |   |
|           |                |                |                | X              | 0              | 1              | 0              | 0              | 0              | 0              | 0         | 1         | 1 |
|           |                |                |                | X              | 1              | 0              | 0              | 0              | 0              | 0              | 0         | 0         | 0 |
|           |                |                |                | X              | 1              | 1              | 1              | 1              | 1              | 1              | 1         | 1         | 0 |
| PRESET    | 1              | 1              | 1              | X              | 0              | 0              | 1              | 1              | 1              | 1              | 1         | 1         |   |
|           |                |                |                | X              | 0              | 1              | 1              | 1              | 1              | 1              | 1         | 1         |   |
|           |                |                |                | X              | 1              | 0              | 1              | 1              | 1              | 1              | 1         | 1         |   |
|           |                |                |                | X              | 1              | 1              | 1              | 1              | 1              | 1              | 1         | 0         |   |

1 = HIGH Voltage Level  
0 = LOW Voltage Level  
X = Immaterial

**DC Characteristics over Operating Temperature Range** (unless otherwise specified)

| Symbol   | Parameter            | 54F/74F |     |     | Units | Conditions  |
|----------|----------------------|---------|-----|-----|-------|---|
|          |                      | Min     | Typ | Max |       |   |
| $I_{CC}$ | Power Supply Current |         | 59  | 89  | mA    | $V_{CC} = \text{Max}$ , $S_0-S_3 = \text{Gnd}$ ;<br>Other Inputs HIGH |

**AC Characteristics:** See Section 3 for waveforms and load configurations

| Symbol                 | Parameter  | 54F/74F   |      |      | 54F  |     | 74F  |      | Units | Fig. No.    |
|------------------------|--|---|------|------|--|-----|--|------|-------|-------------|
|                        |  | $T_A = +25^\circ\text{C}$<br>$V_{CC} = +5.0\text{ V}$<br>$C_L = 50\text{ pF}$ |      |      | $T_A, V_{CC} = \text{Mil}$<br>$C_L = 50\text{ pF}$ |     | $T_A, V_{CC} = \text{Com}$<br>$C_L = 50\text{ pF}$ |      |       |             |
|                        |  | Min   | Typ  | Max  | Min  | Max | Min  | Max  |       |             |
| $t_{PLH}$<br>$t_{PHL}$ | Propagation Delay<br>$C_n$ to $F_i$                  | 2.5   | 8.1  | 12.0 |  |     | 2.5  | 13.0 | ns    | 3-1<br>3-10 |
| $t_{PLH}$<br>$t_{PHL}$ | Propagation Delay<br>Any A or B to Any F             | 4.0   | 10.4 | 15.0 |  |     | 4.0  | 16.0 | ns    | 3-1<br>3-10 |
| $t_{PLH}$<br>$t_{PHL}$ | Propagation Delay<br>$S_i$ to $F_i$                  | 4.5   | 8.3  | 20.0 |  |     | 4.5  | 21.5 | ns    | 3-1<br>3-10 |
| $t_{PLH}$<br>$t_{PHL}$ | Propagation Delay<br>$A_i$ or $B_i$ to $\bar{G}$     | 3.5   | 6.4  | 9.0  |  |     | 3.5  | 10.0 | ns    | 3-1<br>3-10 |
| $t_{PLH}$<br>$t_{PHL}$ | Propagation Delay<br>$A_i$ or $B_i$ to $\bar{P}$     | 4.0   | 7.2  | 10.5 |  |     | 4.0  | 11.5 | ns    | 3-1<br>3-10 |
| $t_{PLH}$<br>$t_{PHL}$ | Propagation Delay<br>$S_i$ to $\bar{G}$ or $\bar{P}$ | 4.0   | 7.8  | 12.0 |  |     | 4.0  | 13.0 | ns    | 3-1<br>3-10 |
|                        |  | 4.5   | 10.2 | 13.5 |  |     | 4.5  | 14.5 |       |             |