

Helping Customers Innovate, Improve & Grow

## Features

- Any frequency between 1 MHz and 220 MHz accurate to 6 decimal places
- LVPECL and LVDS output signaling types
- 0.6ps RMS phase jitter (random) over 12 kHz to 20 MHz bandwidth
- Industrial and extended commercial temperature ranges
- Industry-standard packages: 5.0 mm x 3.2 mm and 7.0 mm x 5.0 mm

## Applications

- SONET, Synchronous Ethernet, SATA, SAS, 10GB Ethernet, Fibre Channel, PCI-Express
- Telecom, networking, broadband, instrumentation

## Performance Specifications

Parameter and Conditions	Symbol	Min.	Typ.	Max.	Unit	Condition
<b>LVPECL and LVDS, Common AC Characteristics</b>						
Output Frequency Range	f	1	–	220	MHz	
Frequency Stability	F_stab	-25	–	+25	PPM	Inclusive of Initial tolerance at 25 °C, and variations over operating temperature, aging, supply voltage and load
		-50	–	+50	PPM	
First Year Aging		-2	–	+2	PPM	25°C
10-year Aging		-5	–	+5	PPM	25°C
Operating Temperature Range	T_use	-40	–	+85	°C	Industrial
		-20	–	+70	°C	Extended Commercial
Start-up Time	T_start	–	–	10	ms	
Duty Cycle	DC	45	–	55	%	Contact Vectron for tighter duty cycle
<b>LVPECL, DC and AC Characteristics</b>						
Supply Voltage	Vdd	2.97	3.3	3.63	V	
		2.25	2.5	2.75	V	
Current Consumption	Idd	–	61	69	mA	Excluding Load Termination Current, Vdd = 3.3V or 2.5V
OE Disable Supply Current	I_OE	–	–	35	mA	OE = Low
Output Disable Leakage Current	I_leak	–	–	1	µA	OE = Low
Maximum Output Current	I-driver	–	–	30	mA	Maximum average current drawn from OUT+ or OUT-
Output High Voltage	VOH	Vdd-1.1	–	Vdd-0.7	V	See Figure 1
Output Low Voltage	VOL	Vdd-1.9	–	Vdd-1.5	V	See Figure 1
Output Differential Voltage Swing	V_Swing	1.2	1.6	2.0	V	See Figure 1
Rise/Fall Time	Tr, Tf	–	300	500	ps	20% to 80%
OE Enable/Disable Time	T_oe	–	–	115	ns	f = 220 MHz - For other frequencies, T_oe = 100ns + 3 period
RMS Period Jitter	T_jitt	–	1.2	1.7	ps	f = 100 MHz, VDD = 3.3V or 2.5V
		–	1.2	1.7	ps	f = 156.25 MHz, VDD = 3.3V or 2.5V
		–	1.2	1.7	ps	f = 212.5 MHz, VDD = 3.3V or 2.5V
RMS Phase Jitter (random)	T_phj	–	0.6	0.85	ps	f = 156.25 MHz, Integration bandwidth = 12 kHz to 20 MHz, all Vdds
<b>LVDS, DC and AC Characteristics</b>						
Supply Voltage	Vdd	2.97	3.3	3.63	V	
		2.25	2.5	2.75	V	
Current Consumption	Idd	–	47	55	mA	Excluding Load Termination Current, Vdd = 3.3V or 2.5V
OE Disable Supply Current	I_OE	–	–	35	mA	OE = Low
Output Disable Leakage Current	I_leak	–	–	1	µA	OE = Low
Differential Output Voltage	VOD	200	350	500	mV	See Figure 4
VOD Magnitude Change	ΔVOD	–	–	50	mV	See Figure 4
Offset Voltage	VOS	1.125	1.2	1.375	V	See Figure 4
VOS Magnitude Change	ΔVOS	–	–	50	mV	See Figure 4
Rise/Fall Time	Tr, Tf	–	495	600	ps	20% to 80%
OE Enable/Disable Time	T_oe	–	–	115	ns	f = 220 MHz - For other frequencies, T_oe = 100ns + 3 period
RMS Period Jitter	T_jitt	–	1.2	1.7	ps	f = 100 MHz, VDD = 3.3V or 2.5V
		–	1.2	1.7	ps	f = 156.25 MHz, VDD = 3.3V or 2.5V
		–	1.2	1.7	ps	f = 212.5 MHz, VDD = 3.3V or 2.5V
RMS Phase Jitter (random)	T_phj	–	0.6	1.0	ps	f = 156.25 MHz, Integration bandwidth = 12 kHz to 20 MHz, all Vdds

# Typical Phase Noise

## Agilent E5052A Signal Source Analyzer

Phase Noise 10.00dB/ Ref 0.000dBc/Hz [Smo]

Carrier 156.249973 MHz 37.052 dBm

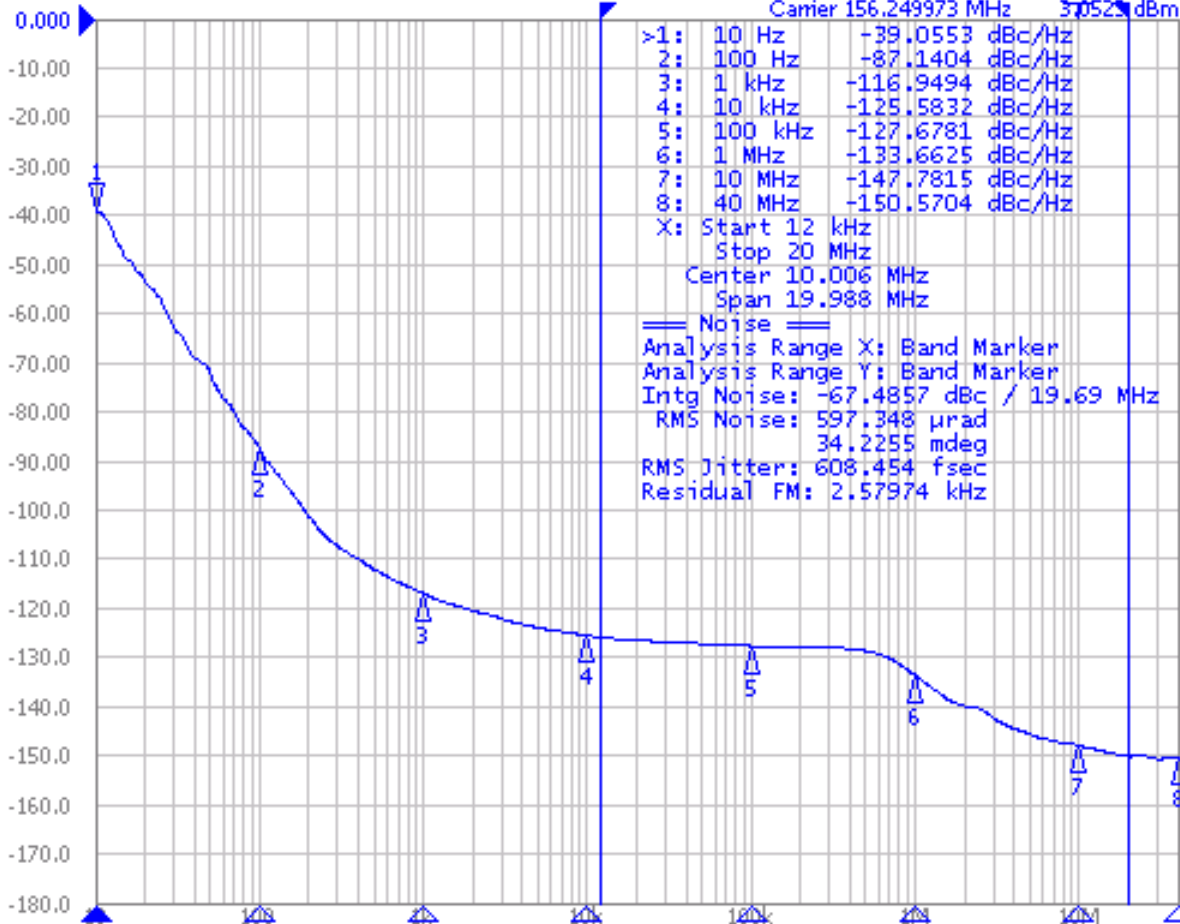

X: Start 12 kHz  
 Stop 20 MHz  
 Center 10.006 MHz  
 Span 19.988 MHz  
 == Noise ==  
 Analysis Range X: Band Marker  
 Analysis Range Y: Band Marker  
 Intg Noise: -67.4857 dBc / 19.69 MHz  
 RMS Noise: 597.348 μrad  
 34.2255 mdeg  
 RMS Jitter: 608.454 fsec  
 Residual FM: 2.57974 kHz

IF Gain 20dB Freq Band [99M-1.5GHz] Omit LO Opt [<150kHz] 853pts

Phase Noise Start 10 Hz Stop 40 MHz 8/8

Phase Noise: Hold Cor Ctrl 1.65V Pow 3.3V Attn 0dB ExtRef Stop Svc 2012-12-20 11:04

Save/Recall

Save State

Recall State

Recall by

File Name

Save

Data Trace ...

Save

Memory Trace ...

Explorer

Return

# Outline Drawing / Packaging

## Package Outline & Dimensions (Unit: mm)

**5.0 x 3.2 x 0.75 mm**

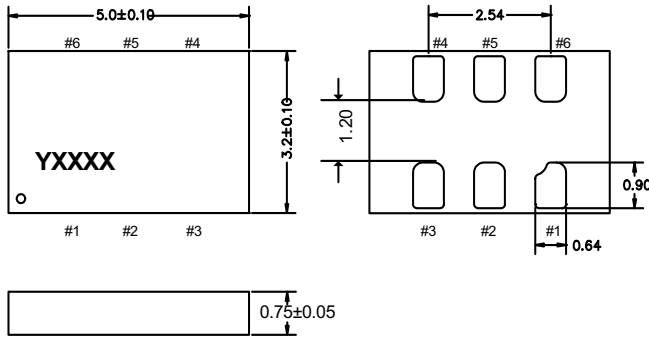

## Recommended Land Pattern (Unit: mm)

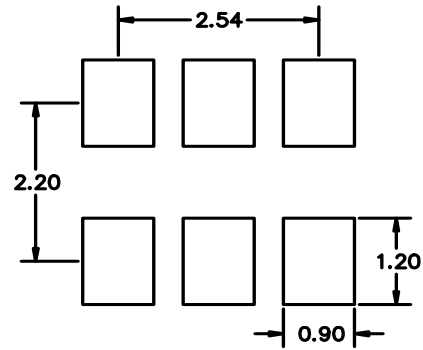

**7.0 x 5.0 x 0.90 mm**

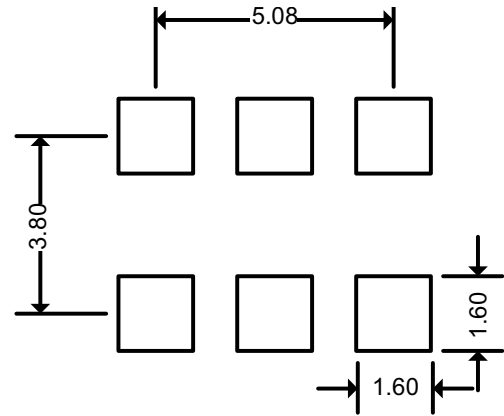
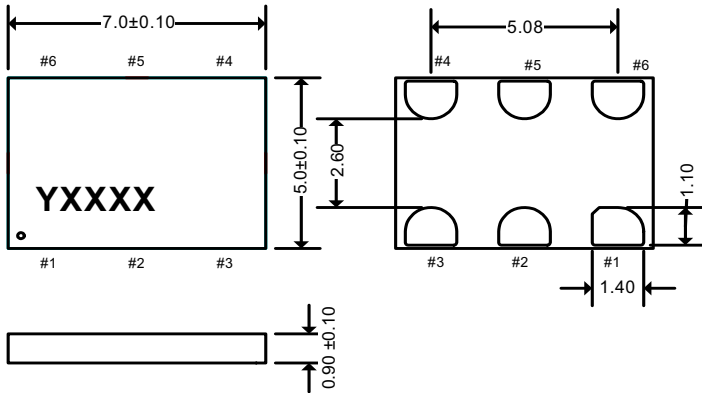

### Pin Connections

Pin	Symbol		Functionality
1	OE	Input	H or Open: specified frequency output L: output is high impedance
2	NC	NA	Do Not Connect; Leave it floating
3	GND	Power	VDD Power Supply Ground
4	OUT+	Output	Oscillator output
5	OUT-	Output	Complementary oscillator output
6	VDD	Power	Power supply voltage

### Top View

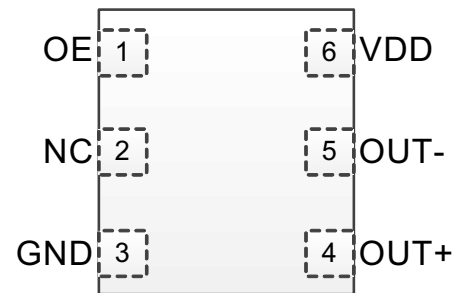

# Termination Circuit Examples

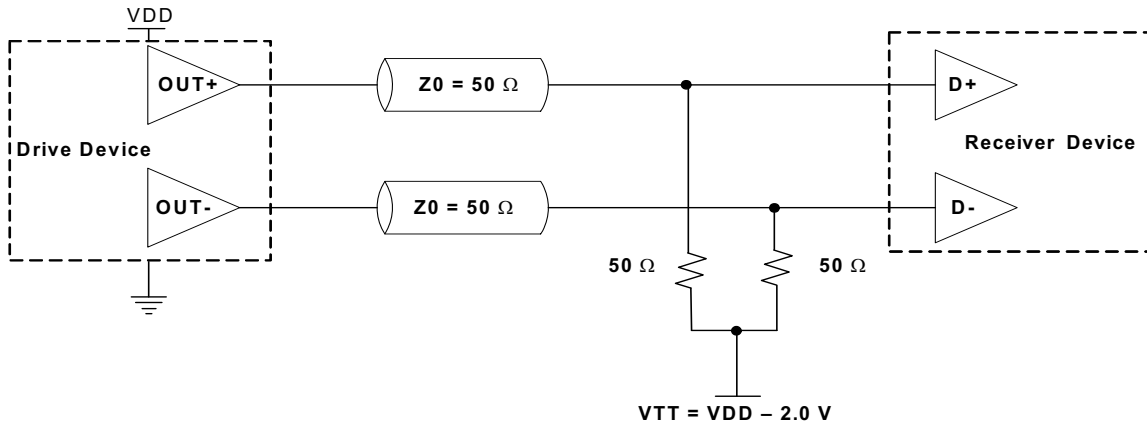

Figure 1. LVPECL Typical Termination

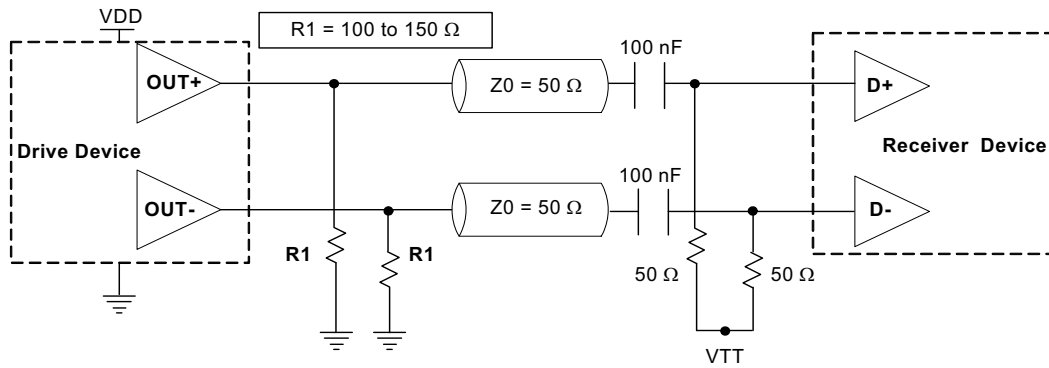

Figure 2. LVPECL AC Coupled Termination

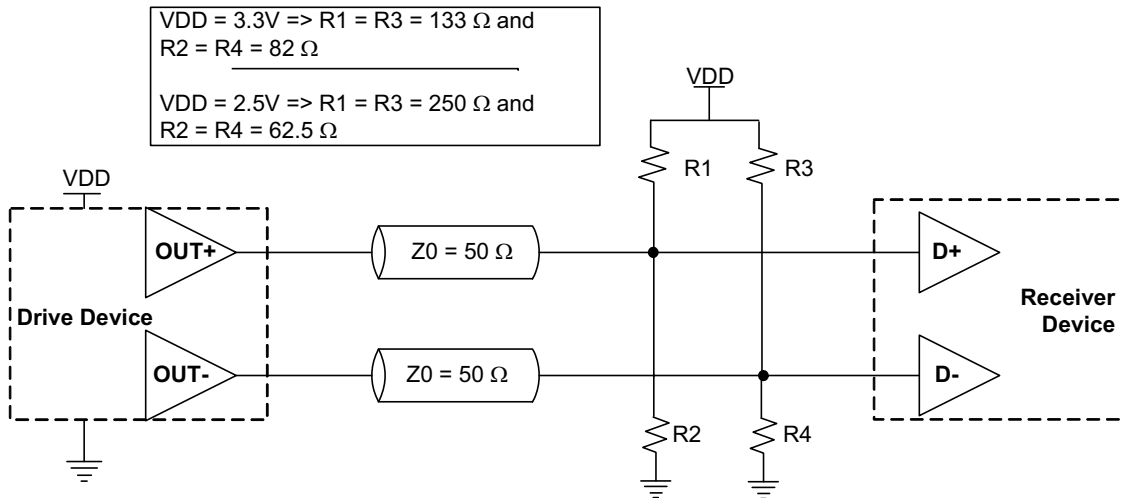

Figure 3. LVPECL with Thevenin Typical Termination

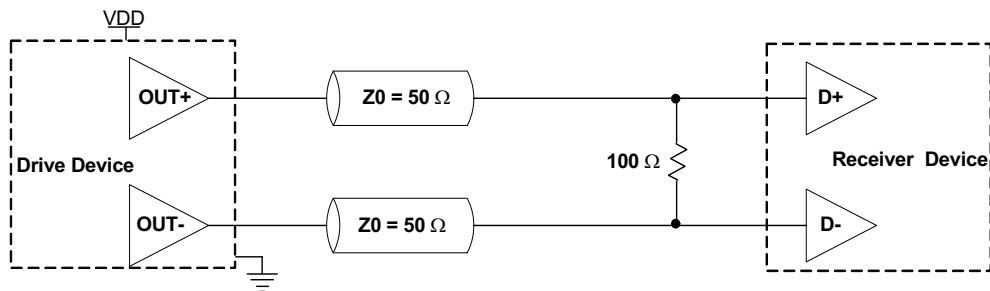

Figure 4. LVDS Single Termination (Load Terminated)

## Absolute Maximum Ratings and Test Compliance

Maximum Ratings			
Parameter	Min.	Max.	Unit
Storage Temperature	-65	150	°C
VDD	-0.5	4	V
Electrostatic Discharge	-	2000	V
Soldering Temperature (follow standard Pb free soldering guidelines)	-	260	°C

Environmental Compliance	
Parameter	Condition/Test Method
Mechanical Shock	MIL-STD-883F, Method 2002
Mechanical Vibration	MIL-STD-883F, Method 2007
Temperature Cycle	JESD22, Method A104
Solderability	MIL-STD-883F, Method 2003
Moisture Sensitivity Level	MSL1 @ 260°C

## Ordering Information

### MO - 9200A E - C 3 F - E E 125M000000

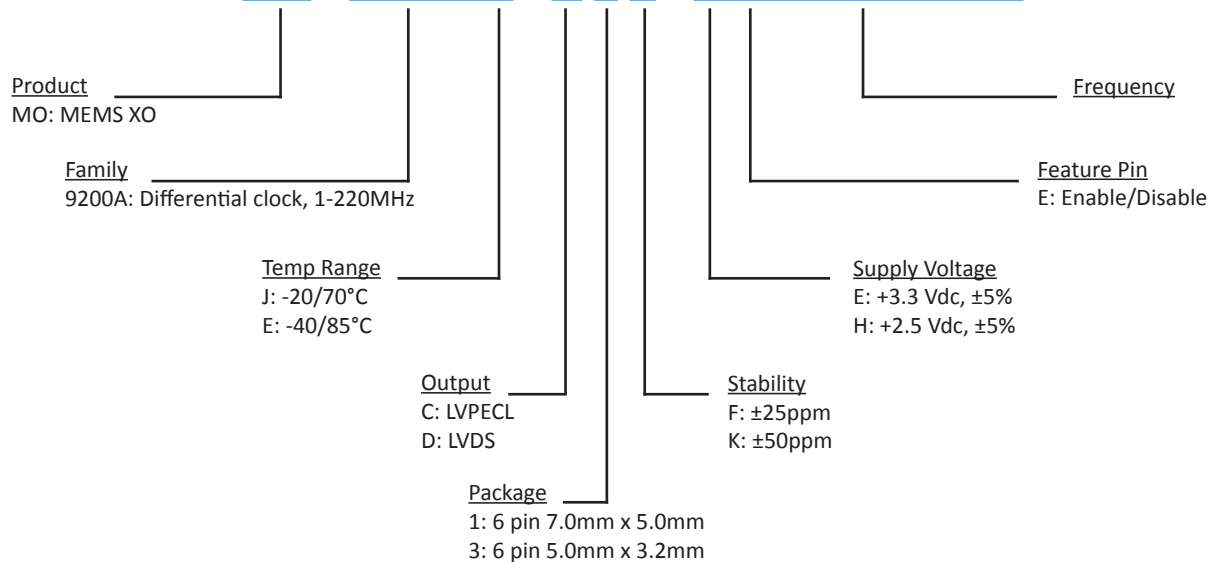

#### Notes:

- Contact factory for improved stabilities or additional product options. Not all options and codes are available at all frequencies.
- Unless otherwise stated all values are valid after warm-up time and refer to typical conditions for supply voltage, frequency control voltage, load, temperature (25°C).
- Subject to technical modification.
- Contact factory for availability.

## For Additional Information, Please Contact

### USA:

Vectron International  
267 Lowell Road  
Hudson, NH 03051  
Tel: 1.888.328.7661  
Fax: 1.888.329.8328

### Europe:

Vectron International  
Landstrasse, D-74924  
Neckarbischofsheim, Germany  
Tel: +49 (0) 7268.801.100  
Fax: +49 (0) 7268.801.282

### Asia:

Vectron International  
1589 Century Avenue, the 19th Floor  
Chamtime International Financial Center  
Shanghai, China  
Tel: 86.21.6081.2888  
Fax: 86.21.6163.3598

#### Disclaimer

Vectron International reserves the right to make changes to the product(s) and or information contained herein without notice. No liability is assumed as a result of their use or application. No rights under any patent accompany the sale of any such product(s) or information.