

1 M-BIT DYNAMIC RAM  
64K-WORD BY 16-BIT, HYPER PAGE MODE (EDO), BYTE WRITE MODE**Description**

The  $\mu$ PD421175 is a 65,536 words by 16 bits CMOS dynamic RAM with optional hyper page mode (EDO).

Hyper page mode (EDO) is a kind of the page mode and is useful for the read operation.

The  $\mu$ PD421175 is packaged in 44-pin plastic TSOP (II) and 40-pin plastic SOJ.

**Features**

- Hyper page mode (EDO)
- 65,536 words by 16 bits organization
- Single +5.0 V  $\pm$ 10 % power supply
- $\overline{\text{CAS}}$  before  $\overline{\text{RAS}}$  refresh,  $\overline{\text{RAS}}$  only refresh, Hidden refresh
- 256 refresh cycles/4 ms
- Fast access and cycle time

★

Part number	Power consumption		Access time (MAX.)	R/W cycle time (MIN.)	Hyper page mode (EDO) cycle time (MIN.)
	Active (MAX.)	Standby (MAX.)			
$\mu$ PD421175-25	687.5 mW	5.5 mW	60 ns	109 ns	25 ns
$\mu$ PD421175-30	632.5 mW	(CMOS level input)	70 ns	124 ns	30 ns
$\mu$ PD421175-35					35 ns

The information in this document is subject to change without notice.

★ Ordering Information

Part number	Access time (MAX.)	Hyper page mode (EDO) cycle time (MIN.)	Package	Refresh
μPD421175G5-25-7JF	60 ns	25 ns	44-pin plastic TSOP (II) (400 mil)	$\overline{\text{CAS}}$ before $\overline{\text{RAS}}$ refresh $\overline{\text{RAS}}$ only refresh Hidden refresh
μPD421175G5-30-7JF	70 ns	30 ns		
μPD421175G5-35-7JF	70 ns	35 ns		
μPD421175LE-25	60 ns	25 ns	40-pin plastic SOJ (400 mil)	
μPD421175LE-30	70 ns	30 ns		
μPD421175LE-35	70 ns	35 ns		

Pin Configurations (Marking Side)

44-pin Plastic TSOP (II) (400 mil)

μPD421175G5-7JF

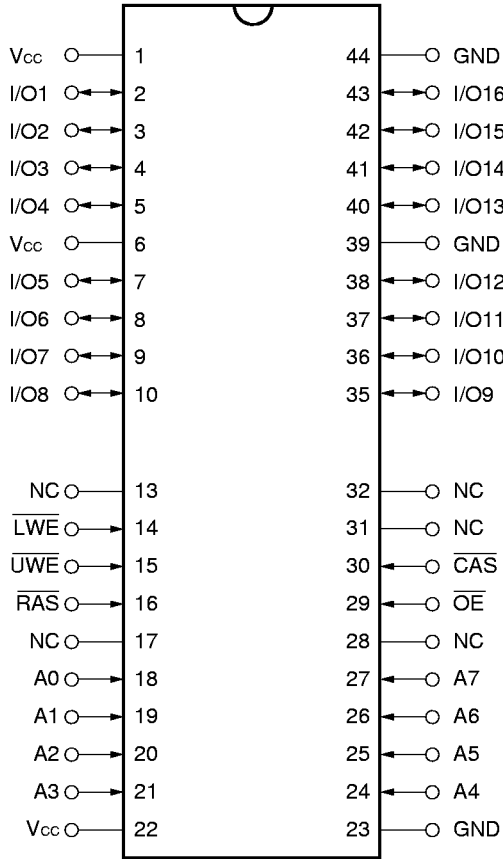

40-pin Plastic SOJ (400 mil)

μPD421175LE

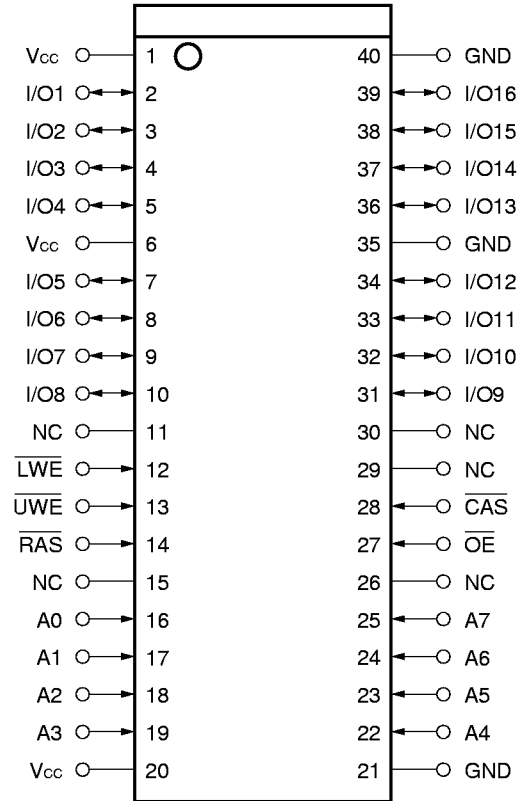

- A0 to A7 : Address Inputs
- I/O1 to I/O16 : Data Inputs/Outputs
- RAS : Row Address Strobe
- CAS : Column Address Strobe
- UWE : Write Enable (upper)
- LWE : Write Enable (lower)
- OE : Output Enable
- V<sub>cc</sub> : Power Supply
- GND : Ground
- NC : No Connection

Block Diagram

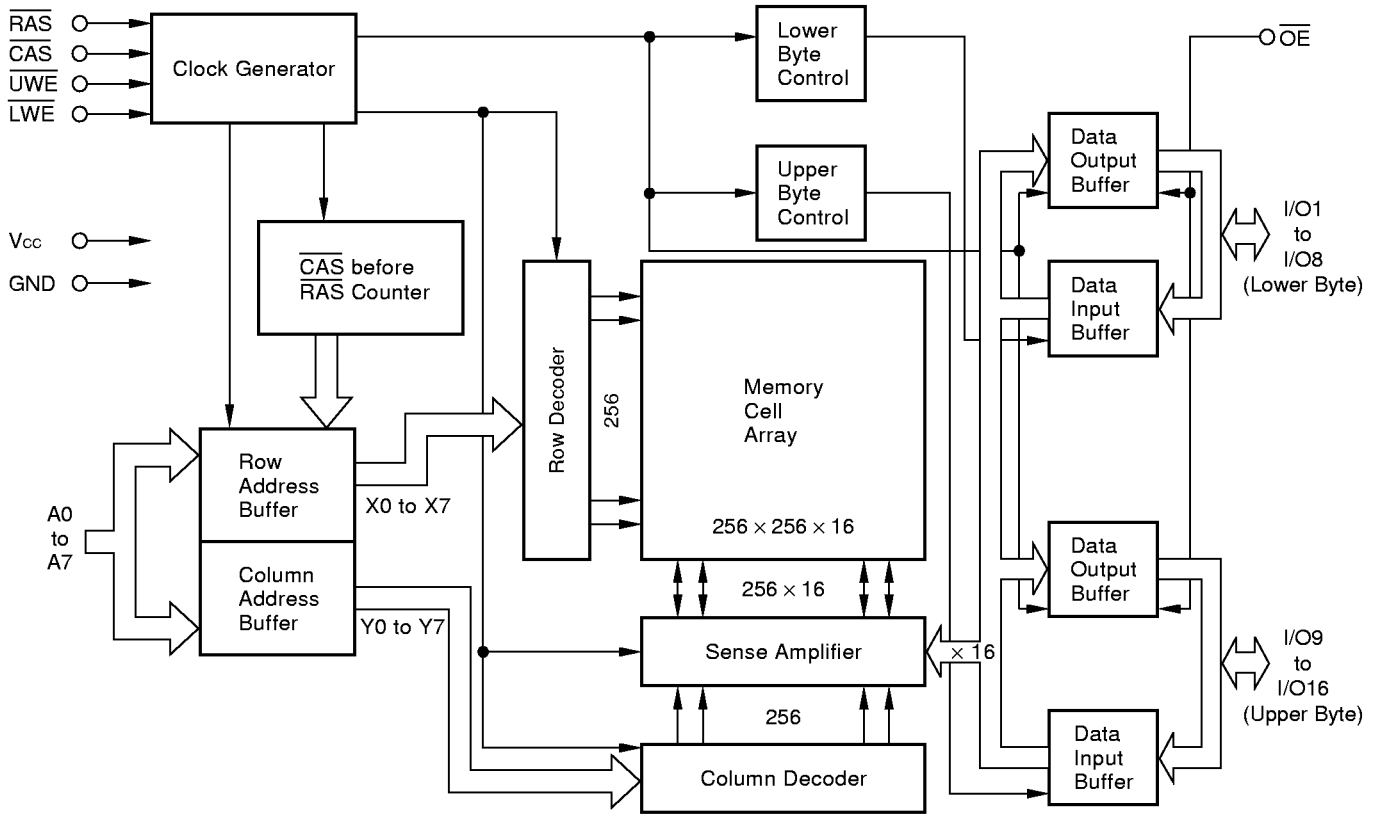

**Input/Output Pin Functions**

The μPD421175 has input pins  $\overline{RAS}$ ,  $\overline{CAS}$ ,  $\overline{UWE}$ ,  $\overline{LWE}$ ,  $\overline{OE}$ , A0 to A7 and input/output pins I/O1 to I/O16.

Pin name	Input/Output	Function
$\overline{RAS}$ (Row address strobe)	Input	$\overline{RAS}$ activates the sense amplifier by latching a row address and selecting a corresponding word line. It refreshes memory cell array of one line selected by the row address. It also selects the following function. • $\overline{CAS}$ before $\overline{RAS}$ refresh
$\overline{CAS}$ (Column address strobe)	Input	$\overline{CAS}$ activates data input/output circuit by latching column address and selecting a digit line connected with the sense amplifier.
A0 to A7 (Address inputs)	Input	Address bus. Input total 16-bit of address signal, upper 8-bit and lower 8-bit in sequence (address multiplex method). Therefore, one word is selected from 65,536-word by 16-bit memory cell array. In actual operation, latch row address by specifying row address and activating $\overline{RAS}$ . Then, switch the address bus to column address and activate $\overline{CAS}$ . Each address is taken into the device when $\overline{RAS}$ and $\overline{CAS}$ are activated. Therefore, the address input setup time ( $t_{ASR}$ , $t_{ASC}$ ) and hold time ( $t_{RAH}$ , $t_{CAH}$ ) are specified for the activation of $\overline{RAS}$ and $\overline{CAS}$ .
$\overline{UWE}$ , $\overline{LWE}$ (Upper, Lower write enable)	Input	Write control signal. Write operation is executed by activating $\overline{RAS}$ , $\overline{CAS}$ and $\overline{UWE}$ , $\overline{LWE}$ .
$\overline{OE}$ (Output enable)	Input	Read control signal. Read operation can be executed by activating $\overline{RAS}$ , $\overline{CAS}$ and $\overline{OE}$ . If $\overline{WE}$ is activated during read operation, $\overline{OE}$ is to be ineffective in the device. Therefore, read operation cannot be executed.
I/O1 to I/O16 (Data inputs/outputs)	Input/Output	16-bit data bus. I/O1 to I/O16 are used to input/output data.

### Hyper Page Mode (EDO)

The hyper page mode (EDO) is a kind of page mode with enhanced features. The two major features of the hyper page mode (EDO) are as follows.

**1. Data output time is extended.**

In the hyper page mode (EDO), the output data is held to the next  $\overline{\text{CAS}}$  cycle's falling edge, instead of the rising edge. For this reason, valid data output time in the hyper page mode (EDO) is extended compared with the fast page mode (= data extend function). In the fast page mode, the data output time becomes shorter as the  $\overline{\text{CAS}}$  cycle time becomes shorter. Therefore, in the hyper page mode (EDO), the timing margin in read cycle is larger than that of the fast page mode even if the  $\overline{\text{CAS}}$  cycle time becomes shorter.

**2. The  $\overline{\text{CAS}}$  cycle time in the hyper page mode (EDO) is shorter than that in the fast page mode.**

In the hyper page mode (EDO), due to the data extend function, the  $\overline{\text{CAS}}$  cycle time can be shorter than in the fast page mode if the timing margin is the same.

Taking a device whose  $t_{\text{RAC}}$  is 60 ns as an example, the  $\overline{\text{CAS}}$  cycle time in the fast page mode is 25 ns while that in the fast page mode is 40 ns.

In the hyper page mode (EDO), read (data out) and write (data in) cycles can be executed repeatedly during one  $\overline{\text{RAS}}$  cycle. The hyper page mode (EDO) allows both read and write operations during one cycle.

The following shows a part of the hyper page mode (EDO) read cycle. Specifications to be observed are described in the next page.

**Hyper Page Mode (EDO) Read Cycle**

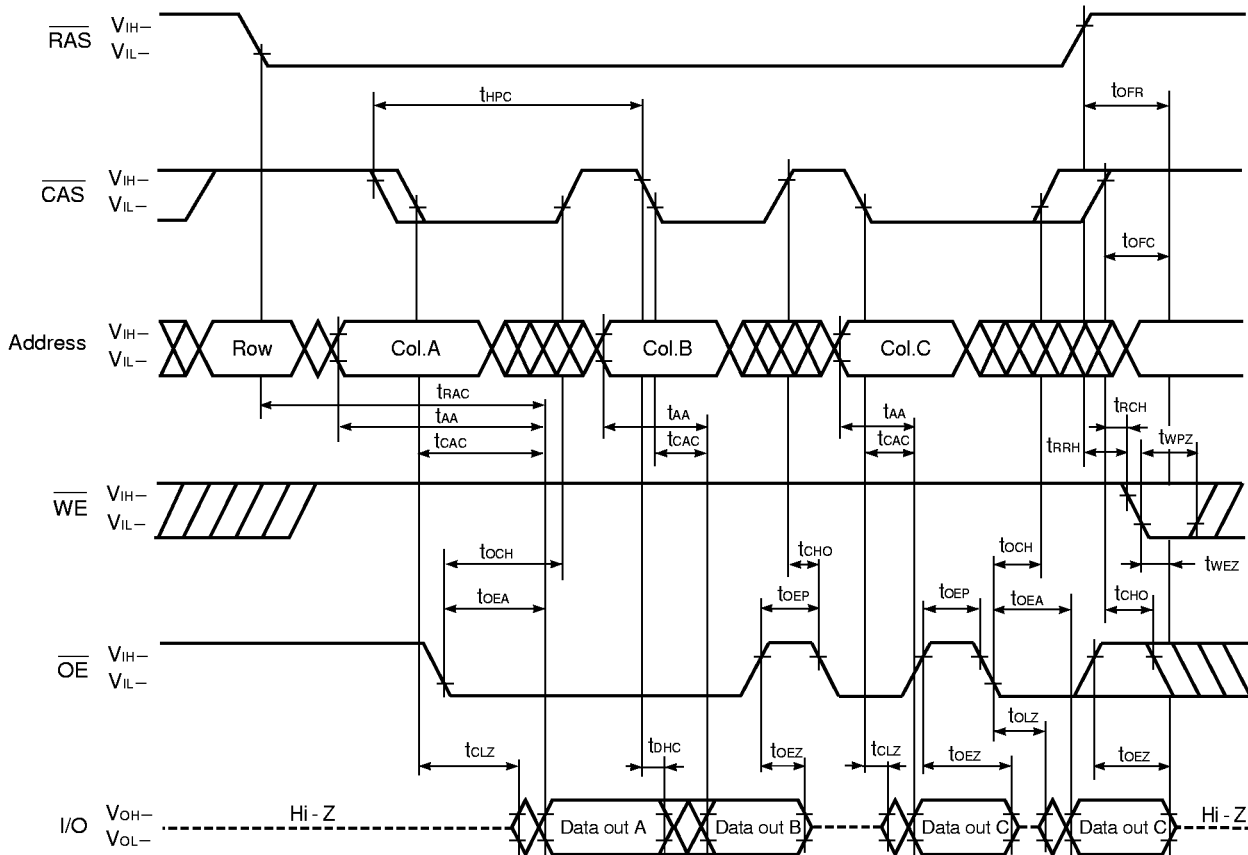

**Cautions when using the hyper page mode (EDO)**

1.  $\overline{\text{CAS}}$  access should be used to operate  $t_{\text{HPC}}$  at the MIN. value.
2. To make I/Os to Hi-Z in read cycle, it is necessary to control  $\overline{\text{RAS}}$ ,  $\overline{\text{CAS}}$ ,  $\overline{\text{WE}}$ ,  $\overline{\text{OE}}$  as follows. The effective specification depends on the state of each signal.
  - (1) Both  $\overline{\text{RAS}}$  and  $\overline{\text{CAS}}$  are inactive (at the end of read cycle)
    - $\overline{\text{WE}}$ : inactive,  $\overline{\text{OE}}$ : active
    - $t_{\text{OFC}}$  is effective when  $\overline{\text{RAS}}$  is inactivated before  $\overline{\text{CAS}}$  is inactivated.
    - $t_{\text{OFR}}$  is effective when  $\overline{\text{CAS}}$  is inactivated before  $\overline{\text{RAS}}$  is inactivated.
    - The slower of  $t_{\text{OFC}}$  and  $t_{\text{OFR}}$  becomes effective.
  - (2) Both  $\overline{\text{RAS}}$  and  $\overline{\text{CAS}}$  are active or either  $\overline{\text{RAS}}$  or  $\overline{\text{CAS}}$  is active (in read cycle)
    - $\overline{\text{WE}}$ ,  $\overline{\text{OE}}$ : inactive  $\cdots$   $t_{\text{OEZ}}$  is effective.
    - Both  $\overline{\text{RAS}}$  and  $\overline{\text{CAS}}$  are inactive or  $\overline{\text{RAS}}$  is active and  $\overline{\text{CAS}}$  is inactive (at the end of read cycle)
    - $\overline{\text{WE}}$ ,  $\overline{\text{OE}}$ : active and either  $t_{\text{RRH}}$  or  $t_{\text{RCH}}$  must be met  $\cdots$   $t_{\text{WEZ}}$  and  $t_{\text{WPZ}}$  are effective.
    - The faster of  $t_{\text{OEZ}}$  and  $t_{\text{WEZ}}$  becomes effective.

The faster of (1) and (2) becomes effective.
3. In read cycle, the effective specification depends on the state of  $\overline{\text{CAS}}$  signal when controlling data output with the  $\overline{\text{OE}}$  signal.
  - (1)  $\overline{\text{CAS}}$ : inactive,  $\overline{\text{OE}}$ : active  $\cdots$   $t_{\text{CHO}}$  is effective.
  - (2)  $\overline{\text{CAS}}$ ,  $\overline{\text{OE}}$ : active  $\cdots$   $t_{\text{CH}}$  is effective.

**Electrical Specifications**

- $\overline{WE}$  means  $\overline{UWE}$  and  $\overline{LWE}$ .
- All voltages are referenced to GND.
- After power up ( $V_{CC} \geq V_{CC(MIN.)}$ ), wait more than 100 μs ( $\overline{RAS}$ ,  $\overline{CAS}$  inactive) and then, execute eight  $\overline{CAS}$  before  $\overline{RAS}$  or  $\overline{RAS}$  only refresh cycles as dummy cycles to initialize internal circuit.

**Absolute Maximum Ratings**

Parameter	Symbol	Condition	Rating	Unit
Voltage on any pin relative to GND	$V_T$		-1.0 to +7.0	V
Supply voltage	$V_{CC}$		-1.0 to +7.0	V
Output current	$I_O$		50	mA
Power dissipation	$P_D$		1	W
Operating ambient temperature	$T_A$		0 to +70	°C
Storage temperature	$T_{stg}$		-55 to +125	°C

**Caution** Exposing the device to stress above those listed in Absolute Maximum Ratings could cause permanent damage. The device is not meant to be operated under conditions outside the limits described in the operational section of this specification. Exposure to Absolute Maximum Rating conditions for extended periods may affect device reliability.

**Recommended Operating Conditions**

Parameter	Symbol	Condition	MIN.	TYP.	MAX.	Unit
Supply voltage	$V_{CC}$		4.5	5.0	5.5	V
High level input voltage	$V_{IH}$		2.4		$V_{CC} + 1.0$	V
Low level input voltage	$V_{IL}$		-1.0		+0.8	V
Operating ambient temperature	$T_A$		0		70	°C

**Capacitance ( $T_A = 25\text{ °C}$ ,  $f = 1\text{ MHz}$ )**

Parameter	Symbol	Test condition	MIN.	TYP.	MAX.	Unit
Input capacitance	$C_{I1}$	Address			5	pF
	$C_{I2}$	$\overline{RAS}$ , $\overline{CAS}$ , $\overline{WE}$ , $\overline{OE}$			7	
Data input/output capacitance	$C_{I/O}$	I/O			7	pF

★ DC Characteristics (Recommended operating conditions unless otherwise noted)

Parameter	Symbol	Test condition	MIN.	MAX.	Unit	Notes
Operating current	I <sub>CC1</sub>	$\overline{RAS}$ , $\overline{CAS}$ cycling	t <sub>RAC</sub> = 60 ns	125	mA	1, 2, 3
		t <sub>RC</sub> = t <sub>RC(MIN)</sub> , I <sub>O</sub> = 0 mA	t <sub>RAC</sub> = 70 ns	115		
Standby current	I <sub>CC2</sub>	$\overline{RAS}$ , $\overline{CAS} \geq V_{IH(MIN)}$ , I <sub>O</sub> = 0 mA		2.0	mA	
		$\overline{RAS}$ , $\overline{CAS} \geq V_{CC} - 0.2$ V, I <sub>O</sub> = 0 mA		1.0		
$\overline{RAS}$ only refresh current	I <sub>CC3</sub>	$\overline{RAS}$ cycling, $\overline{CAS} \geq V_{IH(MIN)}$	t <sub>RAC</sub> = 60 ns	125	mA	1, 2, 3, 4
		t <sub>RC</sub> = t <sub>RC(MIN)</sub> , I <sub>O</sub> = 0 mA	t <sub>RAC</sub> = 70 ns	115		
Operating current (Hyper page mode (EDO))	I <sub>CC4</sub>	$\overline{RAS} \leq V_{IL(MAX)}$ , $\overline{CAS}$ cycling	t <sub>HPC</sub> = 25 ns	115	mA	1, 2, 5
		t <sub>HPC</sub> = t <sub>HPC(MIN)</sub> , I <sub>O</sub> = 0 mA	t <sub>HPC</sub> = 30 ns	105		
			t <sub>HPC</sub> = 35 ns	95		
$\overline{CAS}$ before $\overline{RAS}$ refresh current	I <sub>CC5</sub>	$\overline{RAS}$ cycling	t <sub>RAC</sub> = 60 ns	125	mA	1, 2
		t <sub>RC</sub> = t <sub>RC(MIN)</sub> , I <sub>O</sub> = 0 mA	t <sub>RAC</sub> = 70 ns	115		
Input leakage current	I <sub>I(L)</sub>	V <sub>I</sub> = 0 to 5.5 V All other pins not under test = 0 V	-10	+10	μA	
Output leakage current	I <sub>O(L)</sub>	V <sub>O</sub> = 0 to 5.5 V Output is disabled (Hi-Z)	-10	+10	μA	
High level output voltage	V <sub>OH</sub>	I <sub>O</sub> = -2.5 mA	2.4		V	
Low level output voltage	V <sub>OL</sub>	I <sub>O</sub> = +2.1 mA		0.4	V	

- Notes**
- I<sub>CC1</sub>, I<sub>CC3</sub>, I<sub>CC4</sub> and I<sub>CC5</sub> depend on cycle rates (t<sub>RC</sub> and t<sub>HPC</sub>).
  - Specified values are obtained with outputs unloaded.
  - I<sub>CC1</sub> and I<sub>CC3</sub> are measured assuming that address can be changed once or less during  $\overline{RAS} \leq V_{IL(MAX)}$  and  $\overline{CAS} \geq V_{IH(MIN)}$ .
  - I<sub>CC3</sub> is measured assuming that all column address inputs are held at either high or low.
  - I<sub>CC4</sub> is measured assuming that all column address inputs are switched only once during each hyper page (EDO) cycle.

★ AC Characteristics (Recommended Operating Conditions unless otherwise noted)

AC Characteristics Test Conditions

(1) Input timing specification

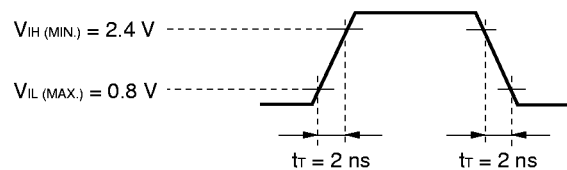

(2) Output timing specification

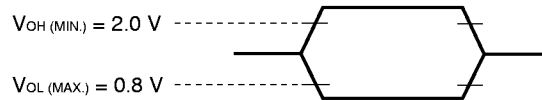

(3) Output load condition

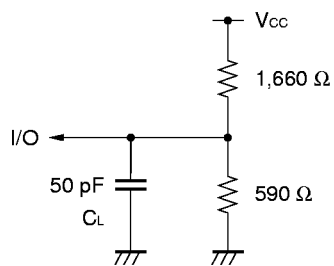

Common to Read, Write, Read Modify Write Cycle

Parameter	Symbol	t <sub>HPC</sub> = 25 ns		t <sub>HPC</sub> = 30 ns		t <sub>HPC</sub> = 35 ns		Unit	Notes
		MIN.	MAX.	MIN.	MAX.	MIN.	MAX.		
Read / Write cycle time	t <sub>RC</sub>	109	–	124	–	124	–	ns	
$\overline{\text{RAS}}$ precharge time	t <sub>RP</sub>	45	–	50	–	50	–	ns	
$\overline{\text{CAS}}$ precharge time	t <sub>CPN</sub>	10	–	10	–	10	–	ns	
$\overline{\text{RAS}}$ pulse width	t <sub>RAS</sub>	60	10,000	70	10,000	70	10,000	ns	
$\overline{\text{CAS}}$ pulse width	t <sub>CAS</sub>	10	10,000	12	10,000	15	10,000	ns	
$\overline{\text{RAS}}$ hold time	t <sub>RSH</sub>	17	–	20	–	20	–	ns	
$\overline{\text{CAS}}$ hold time	t <sub>CSH</sub>	50	–	60	–	70	–	ns	
$\overline{\text{RAS}}$ to $\overline{\text{CAS}}$ delay time	t <sub>RCD</sub>	20	43	20	50	20	50	ns	1
$\overline{\text{RAS}}$ to column address delay time	t <sub>RAD</sub>	15	30	15	35	15	30	ns	1
$\overline{\text{CAS}}$ to $\overline{\text{RAS}}$ precharge time	t <sub>CRP</sub>	5	–	5	–	5	–	ns	2
Row address setup time	t <sub>ASR</sub>	0	–	0	–	0	–	ns	
Row address hold time	t <sub>RAH</sub>	10	–	10	–	10	–	ns	
Column address setup time	t <sub>ASC</sub>	0	–	0	–	0	–	ns	
Column address hold time	t <sub>CAH</sub>	10	–	12	–	15	–	ns	
$\overline{\text{OE}}$ lead time referenced to $\overline{\text{RAS}}$	t <sub>OES</sub>	0	–	0	–	0	–	ns	
$\overline{\text{CAS}}$ to data setup time	t <sub>CLZ</sub>	0	–	0	–	0	–	ns	
$\overline{\text{OE}}$ to data setup time	t <sub>OLZ</sub>	0	–	0	–	0	–	ns	
$\overline{\text{OE}}$ to data delay time	t <sub>OED</sub>	15	–	15	–	15	–	ns	
Masked byte write setup time	t <sub>MCS</sub>	0	–	0	–	0	–	ns	
Masked byte write hold time referenced to $\overline{\text{RAS}}$	t <sub>MRH</sub>	0	–	0	–	0	–	ns	
Masked byte write hold time referenced to $\overline{\text{CAS}}$	t <sub>MCH</sub>	0	–	0	–	0	–	ns	
Transition time (rise and fall)	t <sub>T</sub>	2	50	2	50	2	50	ns	
Refresh time	t <sub>REF</sub>	–	4	–	4	–	4	ms	

Notes 1. For read cycles, access time is defined as follows:

Input conditions	Access time	Access time from $\overline{\text{RAS}}$
t <sub>RAD</sub> ≤ t <sub>RAD</sub> (MAX.) and t <sub>RCD</sub> ≤ t <sub>RCD</sub> (MAX.)	t <sub>RAC</sub> (MAX.)	t <sub>RAC</sub> (MAX.)
t <sub>RAD</sub> > t <sub>RAD</sub> (MAX.) and t <sub>RCD</sub> ≤ t <sub>RCD</sub> (MAX.)	t <sub>AA</sub> (MAX.)	t <sub>RAD</sub> + t <sub>AA</sub> (MAX.)
t <sub>RCD</sub> > t <sub>RCD</sub> (MAX.)	t <sub>CAC</sub> (MAX.)	t <sub>RCD</sub> + t <sub>CAC</sub> (MAX.)

t<sub>RAD</sub>(MAX.) and t<sub>RCD</sub>(MAX.) are specified as reference points only ; they are not restrictive operating parameters. They are used to determine which access time (t<sub>RAC</sub>, t<sub>AA</sub> or t<sub>CAC</sub>) is to be used for finding out when output data will be available. Therefore, the input conditions t<sub>RAD</sub> ≥ t<sub>RAD</sub> (MAX.) and t<sub>RCD</sub> ≥ t<sub>RCD</sub> (MAX.) will not cause any operation problems.

2. t<sub>CRP</sub> (MIN.) requirement is applied to  $\overline{\text{RAS}}$ ,  $\overline{\text{CAS}}$  cycles.

**Read Cycle**

Parameter	Symbol	t <sub>HPC</sub> = 25 ns		t <sub>HPC</sub> = 30 ns		t <sub>HPC</sub> = 35 ns		Unit	Notes
		MIN.	MAX.	MIN.	MAX.	MIN.	MAX.		
Access time from $\overline{RAS}$	t <sub>RAC</sub>	–	60	–	70	–	70	ns	1
Access time from $\overline{CAS}$	t <sub>CAC</sub>	–	17	–	20	–	20	ns	1
Access time from column address	t <sub>AA</sub>	–	30	–	35	–	40	ns	1
Access time from $\overline{OE}$	t <sub>OEA</sub>	–	15	–	20	–	20	ns	
Column address lead time referenced to $\overline{RAS}$	t <sub>RAL</sub>	30	–	35	–	40	–	ns	
Read command setup time	t <sub>RCS</sub>	0	–	0	–	0	–	ns	
Read command hold time referenced to $\overline{RAS}$	t <sub>RRH</sub>	0	–	0	–	0	–	ns	2
Read command hold time referenced to $\overline{CAS}$	t <sub>RCH</sub>	0	–	0	–	0	–	ns	2
Output buffer turn-off delay time from $\overline{OE}$	t <sub>OEZ</sub>	0	15	0	15	0	15	ns	3
$\overline{CAS}$ hold time to $\overline{OE}$	t <sub>CHO</sub>	5	–	5	–	5	–	ns	4

**Notes 1.** For read cycles, access time is defined as follows:

Input conditions	Access time	Access time from $\overline{RAS}$
t <sub>RAD</sub> ≤ t <sub>RAD (MAX.)</sub> and t <sub>RCD</sub> ≤ t <sub>RCD (MAX.)</sub>	t <sub>RAC (MAX.)</sub>	t <sub>RAC (MAX.)</sub>
t <sub>RAD</sub> > t <sub>RAD (MAX.)</sub> and t <sub>RCD</sub> ≤ t <sub>RCD (MAX.)</sub>	t <sub>AA (MAX.)</sub>	t <sub>RAD</sub> + t <sub>AA (MAX.)</sub>
t <sub>RCD</sub> > t <sub>RCD (MAX.)</sub>	t <sub>CAC (MAX.)</sub>	t <sub>RCD</sub> + t <sub>CAC (MAX.)</sub>

t<sub>RAD (MAX.)</sub> and t<sub>RCD (MAX.)</sub> are specified as reference points only; they are not restrictive operating parameters. They are used to determine which access time (t<sub>RAC</sub>, t<sub>AA</sub> or t<sub>CAC</sub>) is to be used for finding out when output data will be available. Therefore, the input conditions t<sub>RAD</sub> ≥ t<sub>RAD (MAX.)</sub> and t<sub>RCD</sub> ≥ t<sub>RCD (MAX.)</sub> will not cause any operation problems.

2. Either t<sub>RCH (MIN.)</sub> or t<sub>RRH (MIN.)</sub> should be met in read cycles.
3. t<sub>OEZ (MAX.)</sub> defines the time when the output achieves the condition of Hi-Z and is not referenced to V<sub>OH</sub> or V<sub>OL</sub>.
4.  $\overline{WE}$ : inactive (in read cycle)  
 $\overline{CAS}$ : inactive,  $\overline{OE}$ : active ..... t<sub>CHO</sub> is effective.  
 $\overline{CAS}$ ,  $\overline{OE}$ : active ..... t<sub>COH</sub> is effective

**Write Cycle**

Parameter	Symbol	t <sub>HPC</sub> = 25 ns		t <sub>HPC</sub> = 30 ns		t <sub>HPC</sub> = 35 ns		Unit	Notes
		MIN.	MAX.	MIN.	MAX.	MIN.	MAX.		
$\overline{WE}$ hold time referenced to $\overline{CAS}$	t <sub>WCH</sub>	10	–	12	–	15	–	ns	1
$\overline{WE}$ pulse width	t <sub>WP</sub>	10	–	12	–	15	–	ns	1
$\overline{WE}$ lead time referenced to $\overline{RAS}$	t <sub>RWL</sub>	15	–	15	–	20	–	ns	
$\overline{WE}$ lead time referenced to $\overline{CAS}$	t <sub>CWL</sub>	10	–	12	–	15	–	ns	
$\overline{WE}$ setup time	t <sub>WCS</sub>	0	–	0	–	0	–	ns	2
$\overline{OE}$ hold time	t <sub>OEH</sub>	0	–	0	–	0	–	ns	
Data-in setup time	t <sub>DS</sub>	0	–	0	–	0	–	ns	3
Data-in hold time	t <sub>DH</sub>	10	–	12	–	15	–	ns	3

- Notes**
1. t<sub>WP</sub> (MIN.) is applied to late write cycles or read modify write cycles. In early write cycles, t<sub>WCH</sub> (MIN.) should be met.
  2. If t<sub>WCS</sub> ≥ t<sub>WCS</sub> (MIN.), the cycle is an early write cycle and the data out will remain Hi-Z through the entire cycle.
  3. t<sub>DS</sub> (MIN.) and t<sub>DH</sub> (MIN.) are referenced to the  $\overline{CAS}$  falling edge in early write cycles. In late write cycles and read modify write cycles, they are referenced to the  $\overline{WE}$  falling edge.

**Read Modify Write Cycle**

Parameter	Symbol	t <sub>HPC</sub> = 25 ns		t <sub>HPC</sub> = 30 ns		t <sub>HPC</sub> = 35 ns		Unit	Note
		MIN.	MAX.	MIN.	MAX.	MIN.	MAX.		
Read modify write cycle time	t <sub>RWC</sub>	145	–	160	–	165	–	ns	
$\overline{RAS}$ to $\overline{WE}$ delay time	t <sub>RWD</sub>	79	–	89	–	89	–	ns	1
$\overline{CAS}$ to $\overline{WE}$ delay time	t <sub>CWD</sub>	36	–	39	–	39	–	ns	1
Column address to $\overline{WE}$ delay time	t <sub>AWD</sub>	49	–	54	–	59	–	ns	1

- Note**
1. If t<sub>WCS</sub> ≥ t<sub>WCS</sub> (MIN.), the cycle is an early write cycle and the data out will remain Hi-Z through the entire cycle. If t<sub>RWD</sub> ≥ t<sub>RWD</sub> (MIN.), t<sub>CWD</sub> ≥ t<sub>CWD</sub> (MIN.), t<sub>AWD</sub> ≥ t<sub>AWD</sub> (MIN.) and t<sub>CPWD</sub> ≥ t<sub>CPWD</sub> (MIN.), the cycle is a read modify write cycle and the data out will contain data read from the selected cell. If neither of the above conditions is met, the state of the data out is indeterminate.

**Hyper Page Mode (EDO)**

Parameter	Symbol	t <sub>HPC</sub> = 25 ns		t <sub>HPC</sub> = 30 ns		t <sub>HPC</sub> = 35 ns		Unit	Notes
		MIN.	MAX.	MIN.	MAX.	MIN.	MAX.		
Read / Write cycle time	t <sub>HPC</sub>	25	–	30	–	35	–	ns	1
$\overline{\text{RAS}}$ pulse width	t <sub>RASP</sub>	60	125,000	70	125,000	70	125,000	ns	
$\overline{\text{CAS}}$ pulse width	t <sub>H<sub>CAS</sub></sub>	10	10,000	12	10,000	15	10,000	ns	
$\overline{\text{CAS}}$ precharge time	t <sub>CP</sub>	10	–	10	–	10	–	ns	
Access time from $\overline{\text{CAS}}$ precharge	t <sub>ACP</sub>	–	33	–	40	–	45	ns	
$\overline{\text{CAS}}$ precharge to $\overline{\text{WE}}$ delay time	t <sub>CPWD</sub>	52	–	59	–	64	–	ns	2
$\overline{\text{RAS}}$ hold time from $\overline{\text{CAS}}$ precharge	t <sub>RHCP</sub>	33	–	40	–	45	–	ns	
Read modify write cycle time	t <sub>HPRWC</sub>	66	–	75	–	83	–	ns	
Data output hold time	t <sub>DHC</sub>	5	–	5	–	5	–	ns	
$\overline{\text{OE}}$ to $\overline{\text{CAS}}$ hold time	t <sub>OCH</sub>	5	–	5	–	5	–	ns	3
$\overline{\text{OE}}$ precharge time	t <sub>OEP</sub>	5	–	5	–	5	–	ns	
Output buffer turn-off delay from $\overline{\text{WE}}$	t <sub>WEZ</sub>	0	15	0	15	0	15	ns	4,5
$\overline{\text{WE}}$ pulse width	t <sub>WPZ</sub>	10	–	10	–	10	–	ns	5
Output buffer turn-off delay from $\overline{\text{RAS}}$	t <sub>OFR</sub>	0	15	0	15	0	15	ns	4,5
Output buffer turn-off delay from $\overline{\text{CAS}}$	t <sub>OFC</sub>	0	15	0	15	0	15	ns	4,5
Access time from previous $\overline{\text{WE}}$ (Hyper page mode (EDO) read modify write cycle)	t <sub>AWE</sub>	–	55	–	65	–	75	ns	
Access time from previous $\overline{\text{CAS}}$ (Hyper page mode (EDO) write and read cycle)	t <sub>ACE</sub>	–	55	–	65	–	75	ns	

- Notes**
- t<sub>HPC</sub> (MIN.) is applied to  $\overline{\text{CAS}}$  access.
  - If  $t_{\text{WCS}} \geq t_{\text{WCS}}(\text{MIN.})$ , the cycle is an early write cycle and the data out will remain Hi-Z through the entire cycle. If  $t_{\text{RWD}} \geq t_{\text{RWD}}(\text{MIN.})$ ,  $t_{\text{CWD}} \geq t_{\text{CWD}}(\text{MIN.})$ ,  $t_{\text{AWD}} \geq t_{\text{AWD}}(\text{MIN.})$  and  $t_{\text{CPWD}} \geq t_{\text{CPWD}}(\text{MIN.})$ , the cycle is a read modify write cycle and the data out will contain data read from the selected cell. If neither of the above conditions is met, the state of the data out is indeterminate.
  - $\overline{\text{WE}}$ : inactive (in read cycle)  
 $\overline{\text{CAS}}$ : inactive,  $\overline{\text{OE}}$ : active ..... t<sub>CHO</sub> is effective.  
 $\overline{\text{CAS}}$ ,  $\overline{\text{OE}}$ : active ..... t<sub>OCH</sub> is effective.
  - t<sub>OFC</sub> (MAX.), t<sub>OFR</sub> (MAX.) and t<sub>WEZ</sub> (MAX.) define the time when the output achieves the conditions of Hi-Z and is not referenced to V<sub>OH</sub> or V<sub>OL</sub>.
  - To make I/Os to Hi-Z in read cycle, it is necessary to control  $\overline{\text{RAS}}$ ,  $\overline{\text{CAS}}$ ,  $\overline{\text{WE}}$ ,  $\overline{\text{OE}}$  as follows. The effective specification depends on state of each signal.
    - Both  $\overline{\text{RAS}}$  and  $\overline{\text{CAS}}$  are inactive (at the end of the read cycle)  
 $\overline{\text{WE}}$ : inactive,  $\overline{\text{OE}}$ : active  
 t<sub>OFC</sub> is effective when  $\overline{\text{RAS}}$  is inactivated before  $\overline{\text{CAS}}$  is inactivated.  
 t<sub>OFR</sub> is effective when  $\overline{\text{CAS}}$  is inactivated before  $\overline{\text{RAS}}$  is inactivated.  
 The slower of t<sub>OFC</sub> and t<sub>OFR</sub> becomes effective.
    - Both  $\overline{\text{RAS}}$  and  $\overline{\text{CAS}}$  are active or either  $\overline{\text{RAS}}$  or  $\overline{\text{CAS}}$  is active (in read cycle)  
 $\overline{\text{WE}}$ ,  $\overline{\text{OE}}$ : inactive ..... t<sub>OEZ</sub> is effective.  
 Both  $\overline{\text{RAS}}$  and  $\overline{\text{CAS}}$  are inactive or  $\overline{\text{RAS}}$  is active and  $\overline{\text{CAS}}$  is inactive (at the end of read cycle)  
 $\overline{\text{WE}}$ ,  $\overline{\text{OE}}$ : active and either t<sub>RRH</sub> or t<sub>RCH</sub> must be met ..... t<sub>WEZ</sub> and t<sub>WPZ</sub> are effective.  
 The faster of t<sub>OEZ</sub> and t<sub>WEZ</sub> becomes effective.
- The faster of (1) and (2) becomes effective.

Refresh Cycle

Parameter	Symbol	t <sub>HPC</sub> = 25 ns		t <sub>HPC</sub> = 30 ns		t <sub>HPC</sub> = 35 ns		Unit	Note
		MIN.	MAX.	MIN.	MAX.	MIN.	MAX.		
$\overline{\text{CAS}}$ setup time	t <sub>CSR</sub>	5	–	5	–	5	–	ns	
$\overline{\text{CAS}}$ hold time ( $\overline{\text{CAS}}$ before $\overline{\text{RAS}}$ refresh)	t <sub>CHR</sub>	10	–	10	–	10	–	ns	
$\overline{\text{RAS}}$ precharge $\overline{\text{CAS}}$ hold time	t <sub>RPC</sub>	5	–	5	–	5	–	ns	
$\overline{\text{WE}}$ hold time	t <sub>WHR</sub>	15	–	15	–	15	–	ns	



Early Write Cycle

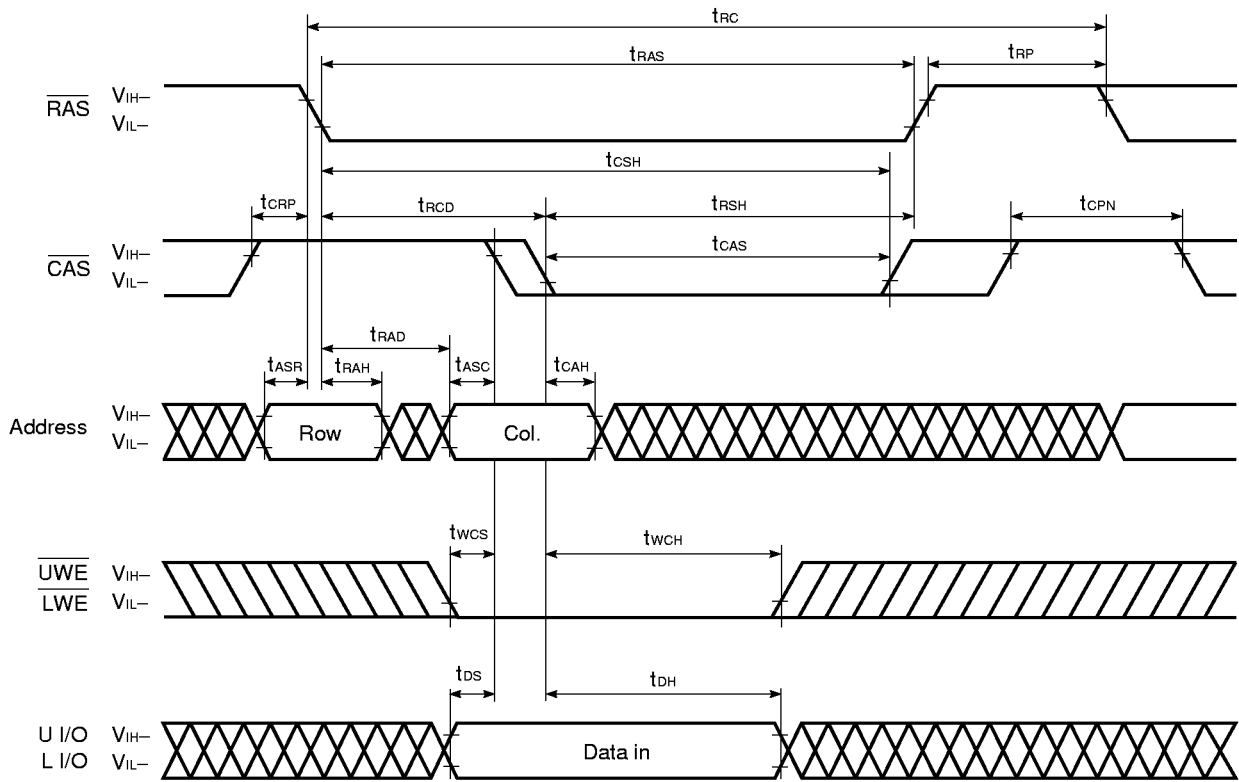

Remark  $\overline{OE}$ : Don't care

Upper Byte Early Write Cycle

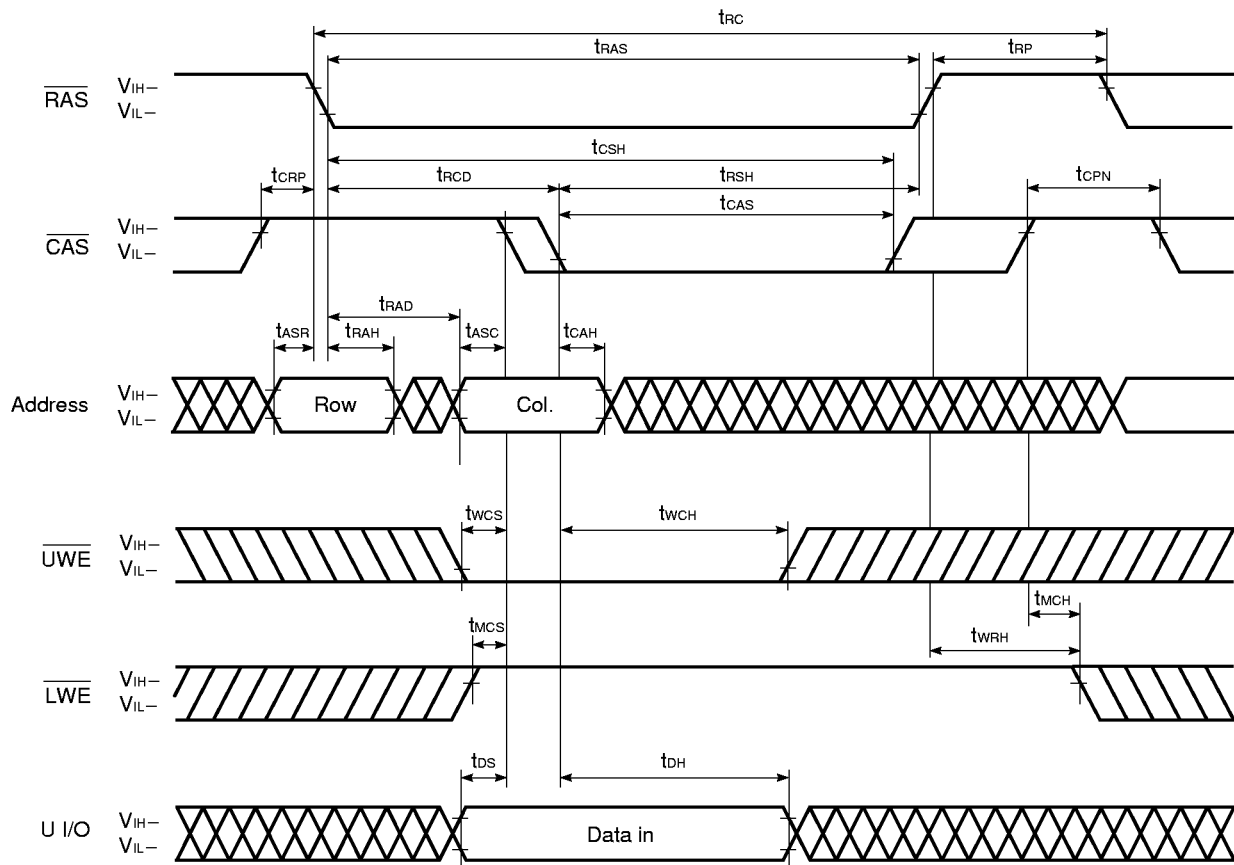

Remark  $\overline{OE}$ , L I/O: Don't care

Lower Byte Early Write Cycle

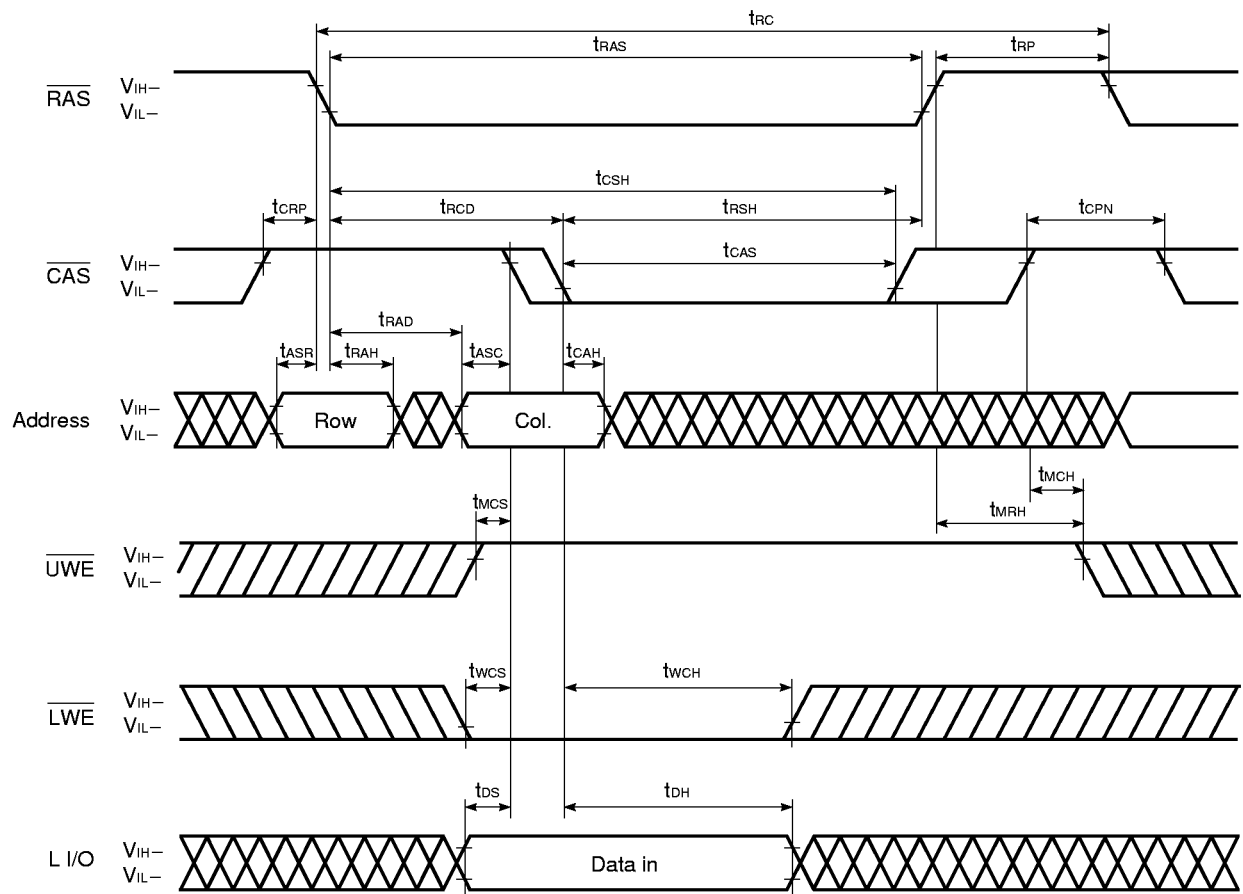

Remark  $\overline{OE}$ , U I/O: Don't care

Late Write Cycle

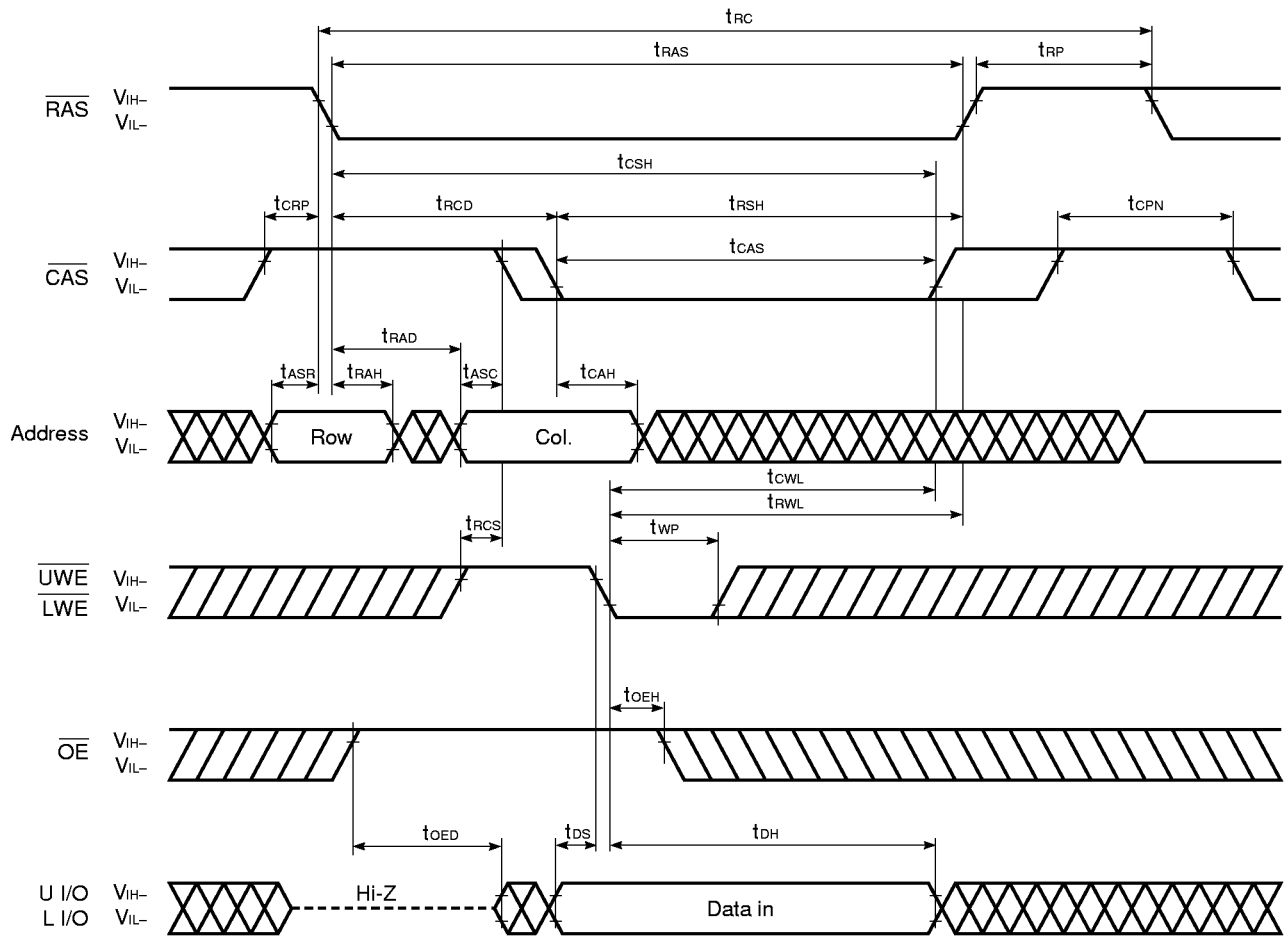

Upper Byte Late Write Cycle

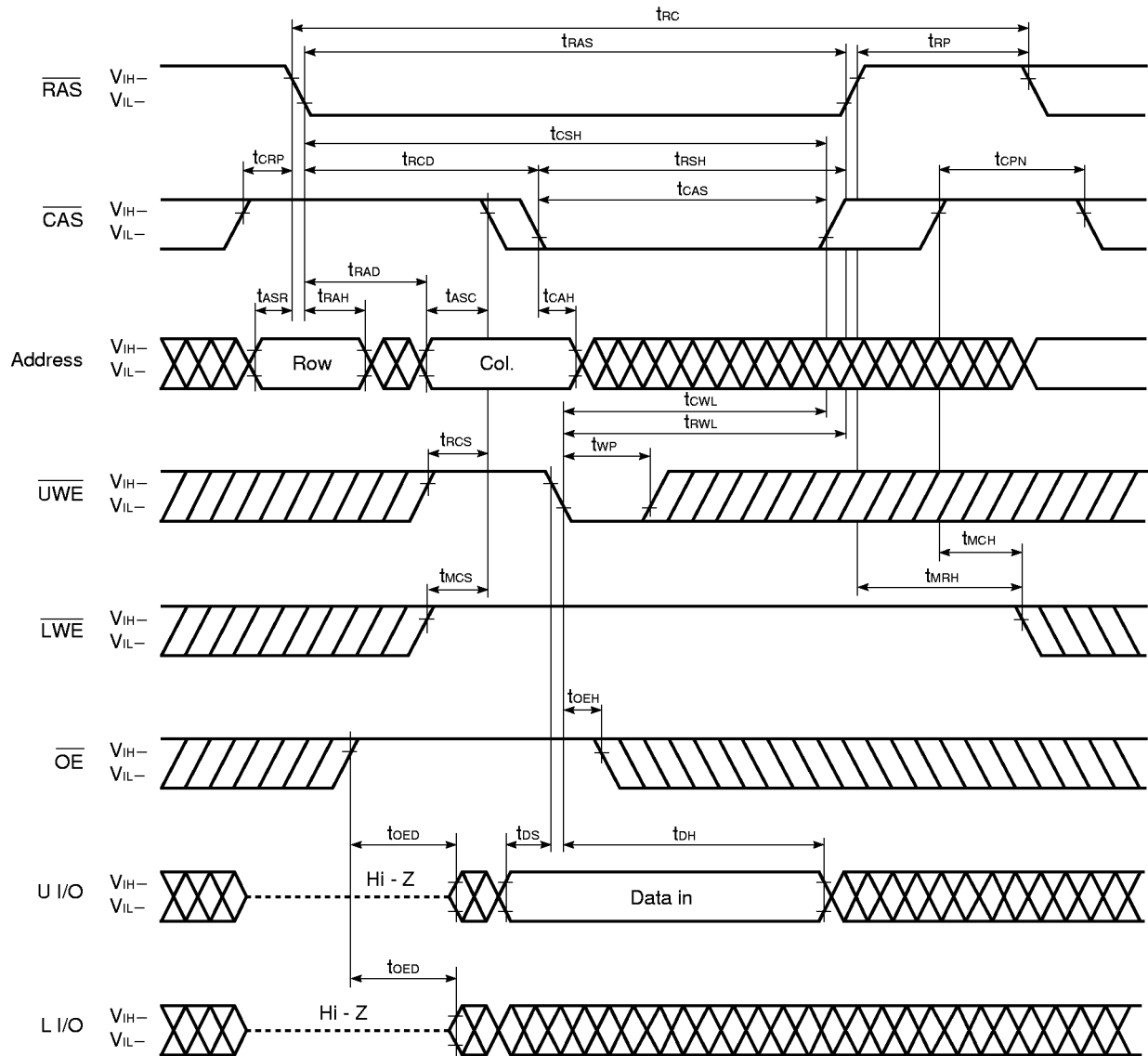

Lower Byte Late Write Cycle

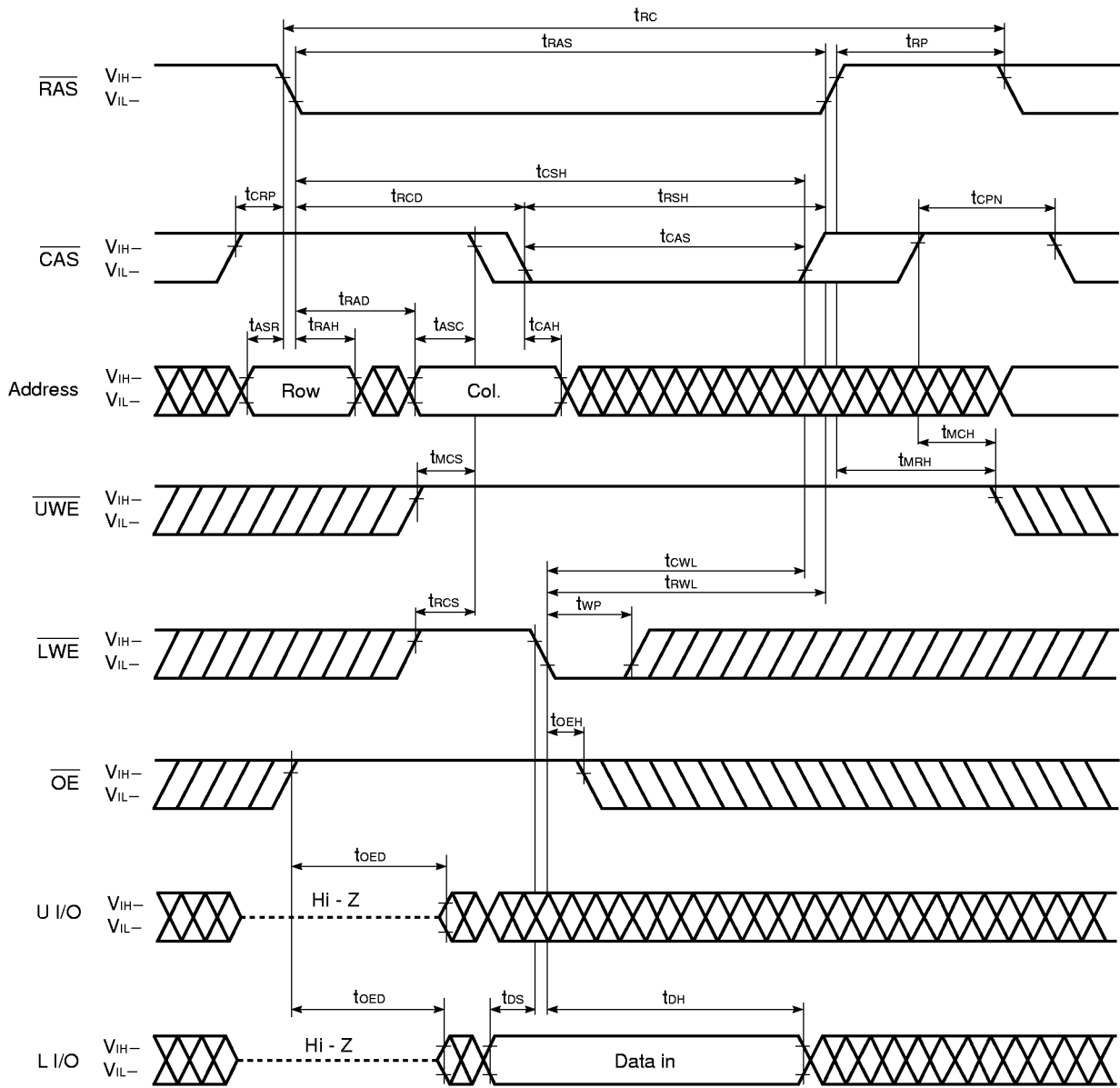

Read Modify Write Cycle

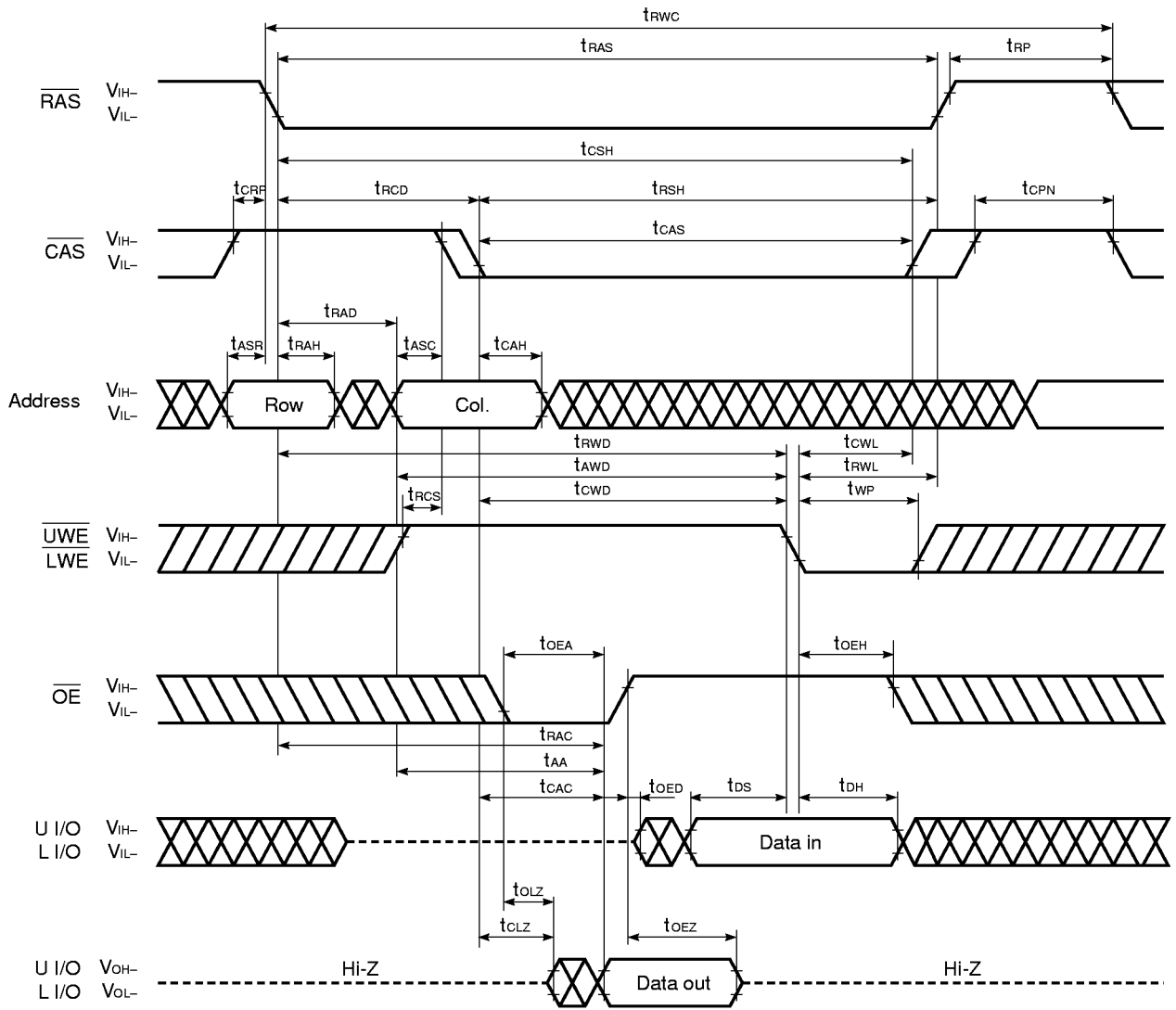

Upper Byte Read Modify Write Cycle

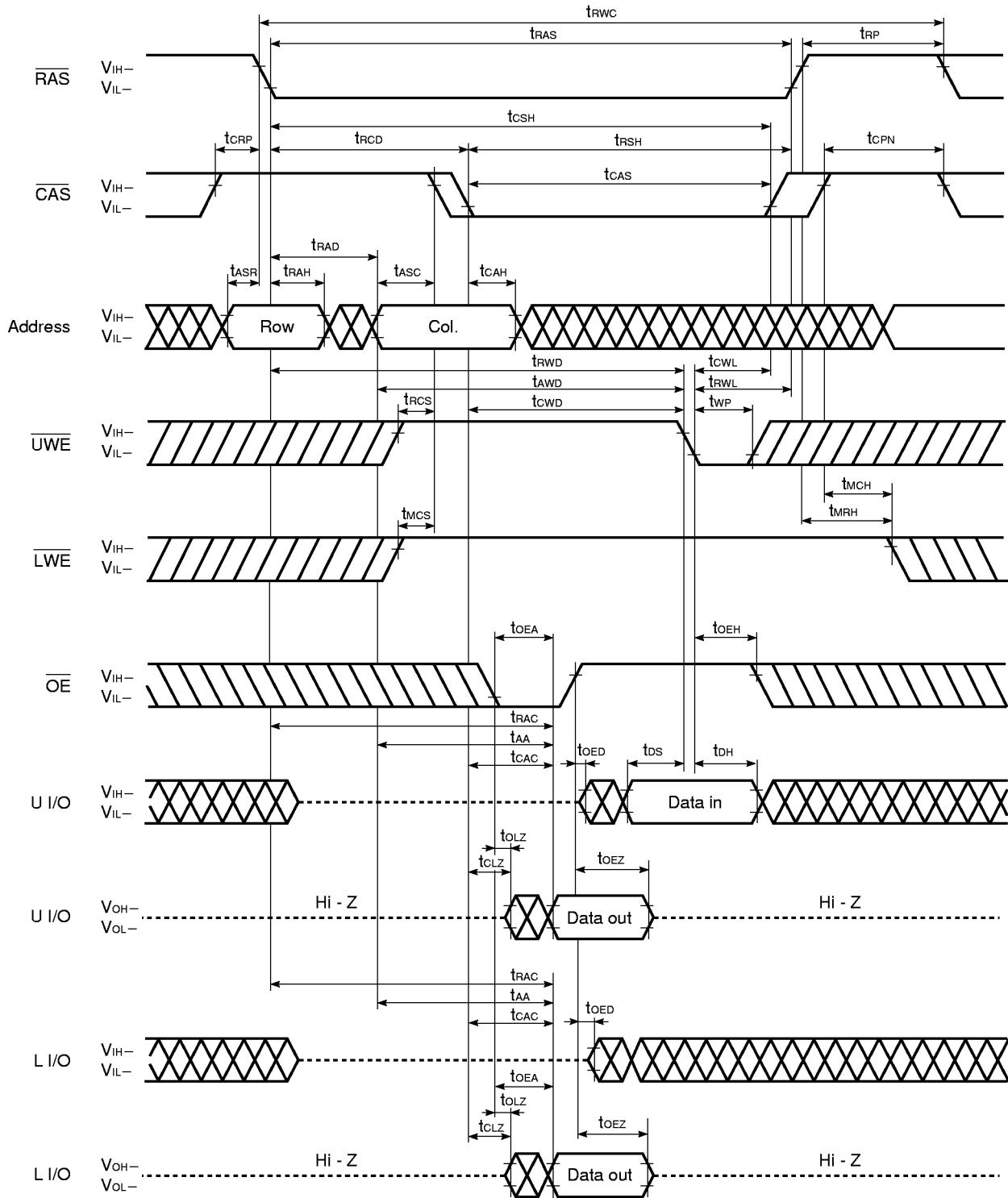

Lower Byte Read Modify Write Cycle

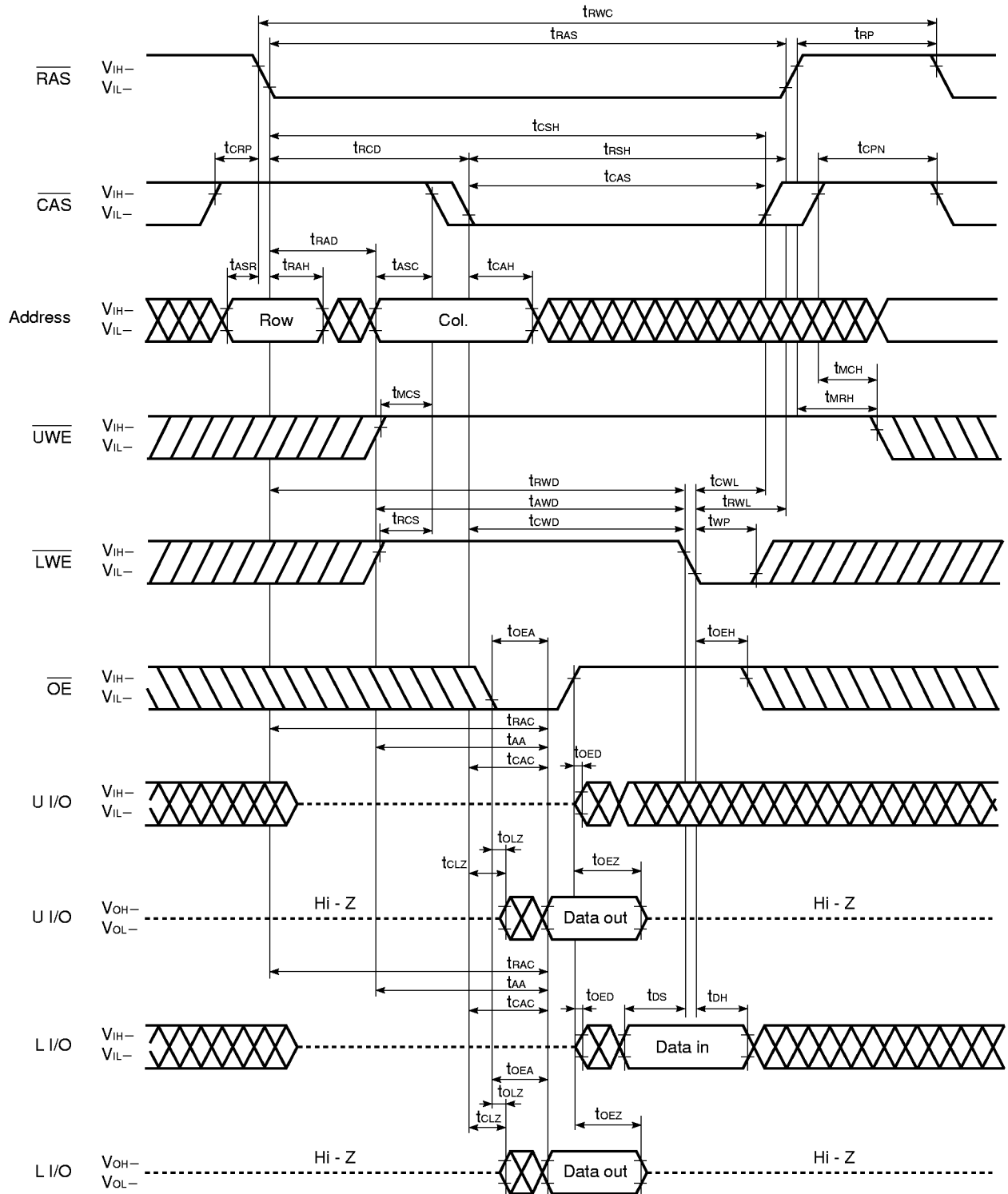







Hyper Page Mode (EDO) Early Write Cycle

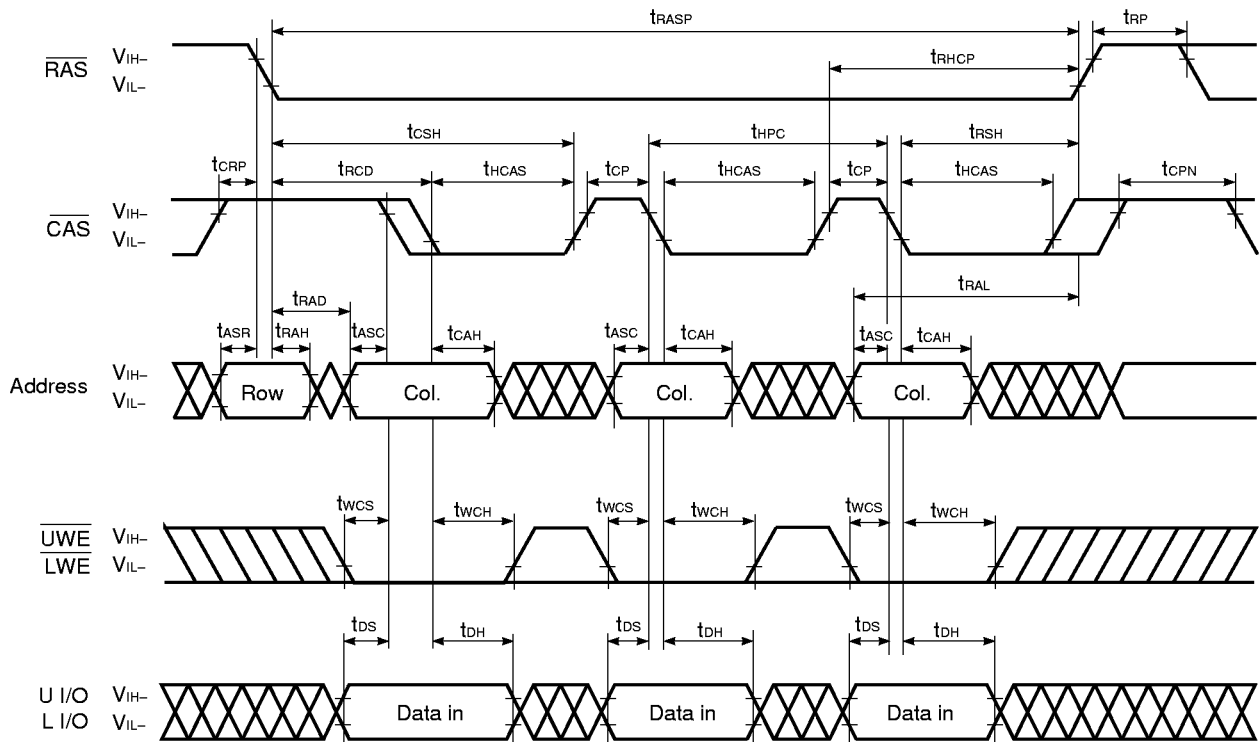

- Remarks**
1.  $\overline{OE}$ : Don't care
  2. In the hyper page mode (EDO), read, write and read modify write cycles are available for each of the consecutive  $\overline{CAS}$  cycles within the same  $\overline{RAS}$  cycle.

Hyper Page Mode (EDO) Byte Early Write Cycle

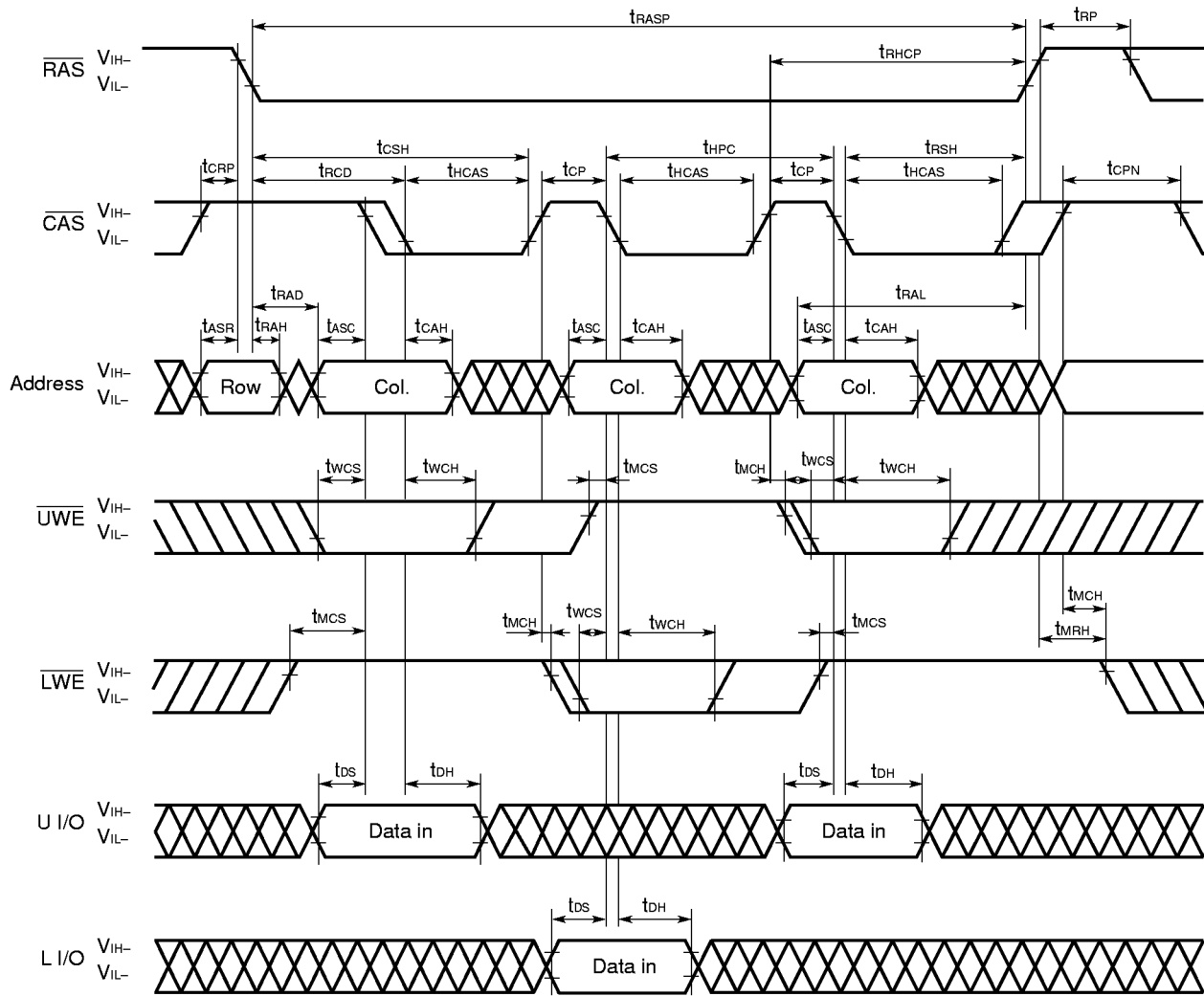

- Remarks**
1.  $\overline{OE}$ : Don't care
  2. In the hyper page mode (EDO), read, write and read modify write cycles are available for each of the consecutive  $\overline{CAS}$  cycles within the same  $\overline{RAS}$  cycle.
  3. This cycle can be used to control either  $\overline{UWE}$  or  $\overline{LWE}$  only. Or, it can be used to control  $\overline{UWE}$  or  $\overline{LWE}$  simultaneously, or at random.



Hyper Page Mode (EDO) Byte Late Write Cycle

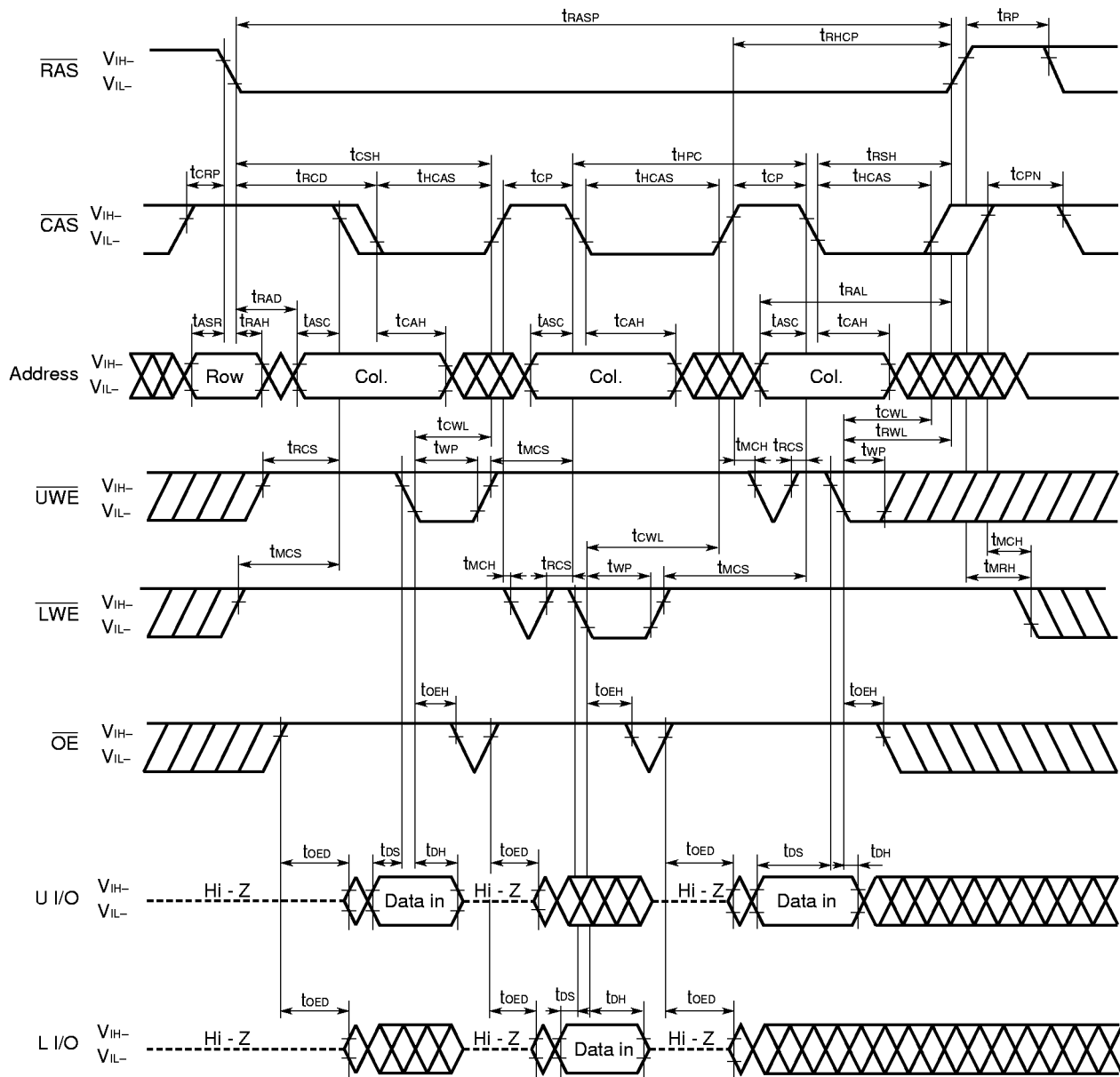

- Remarks**
1. In the hyper page mode (EDO), read, write and read modify write cycles are available for each of the consecutive  $\overline{\text{CAS}}$  cycles within the same  $\overline{\text{RAS}}$  cycle.
  2. This cycle can be used to control either  $\overline{\text{UWE}}$  or  $\overline{\text{LWE}}$  only. Or, it can be used to control  $\overline{\text{UWE}}$  or  $\overline{\text{LWE}}$  simultaneously, or at random.



Hyper Page Mode (EDO) Byte Read Modify Write Cycle

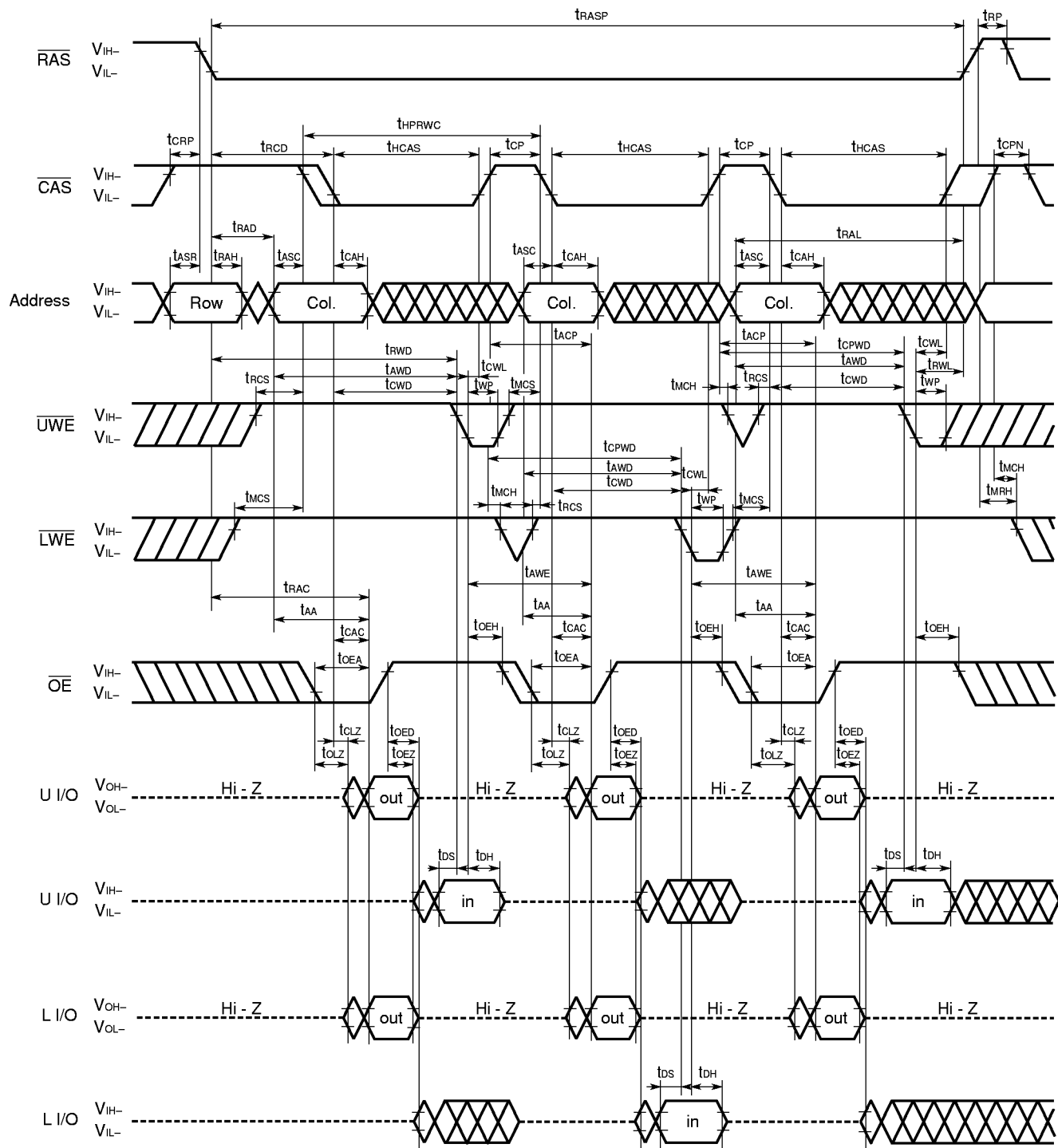

- Remarks**
1. In the hyper page mode (EDO), read, write and read modify write cycles are available for each of the consecutive  $\overline{CAS}$  cycles within the same  $\overline{RAS}$  cycle.
  2. This cycle can be used to control either  $\overline{UWE}$  or  $\overline{LWE}$  only. Or, it can be used to control  $\overline{UWE}$  or  $\overline{LWE}$  simultaneously, or at random.

Hyper Page Mode (EDO) Read and Write Cycle

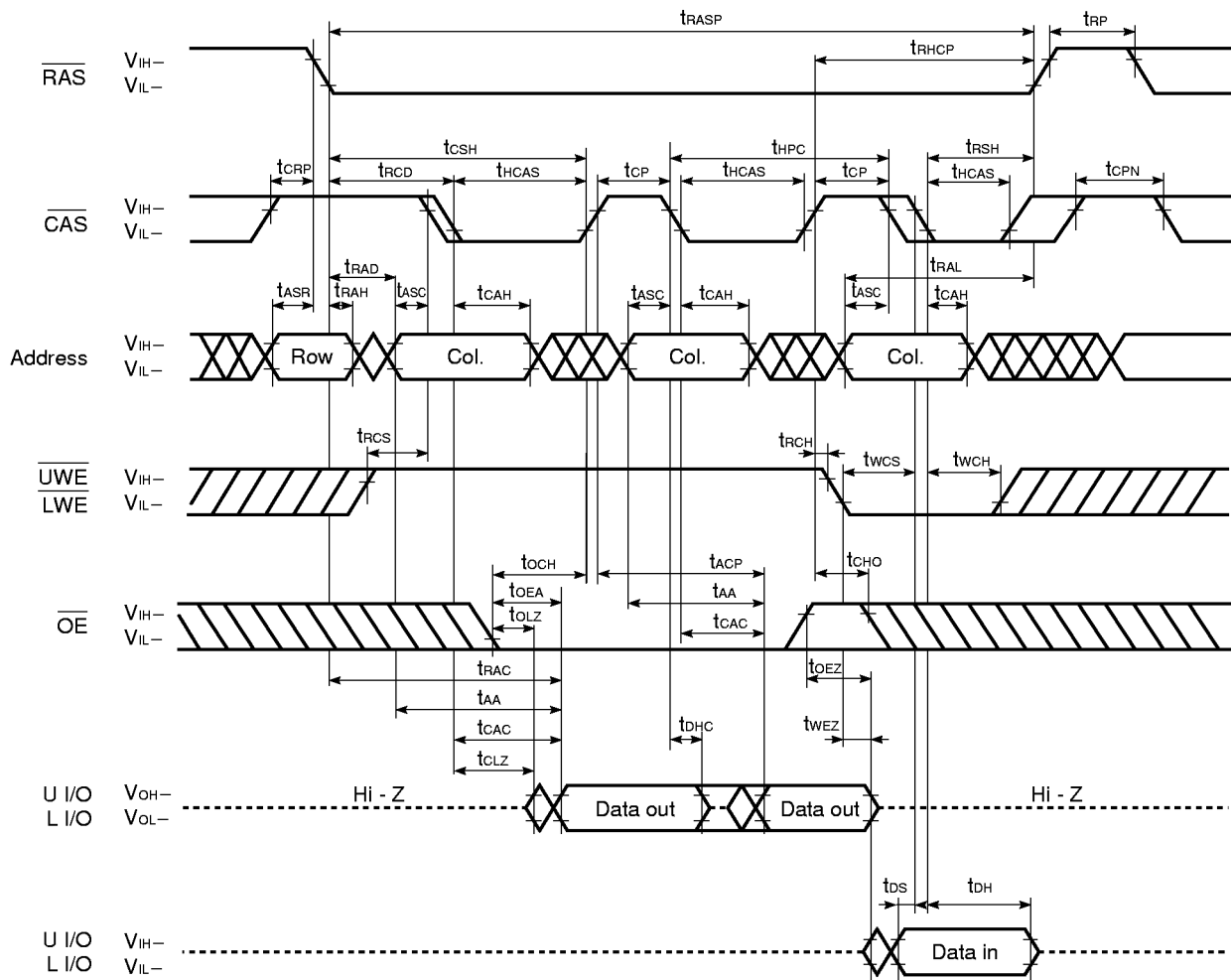

**Remark** In the hyper page mode (EDO), read, write and read modify write cycles are available for each of the consecutive  $\overline{\text{CAS}}$  cycles within the same  $\overline{\text{RAS}}$  cycle.

Hyper Page Mode (EDO) Write and Read Cycle

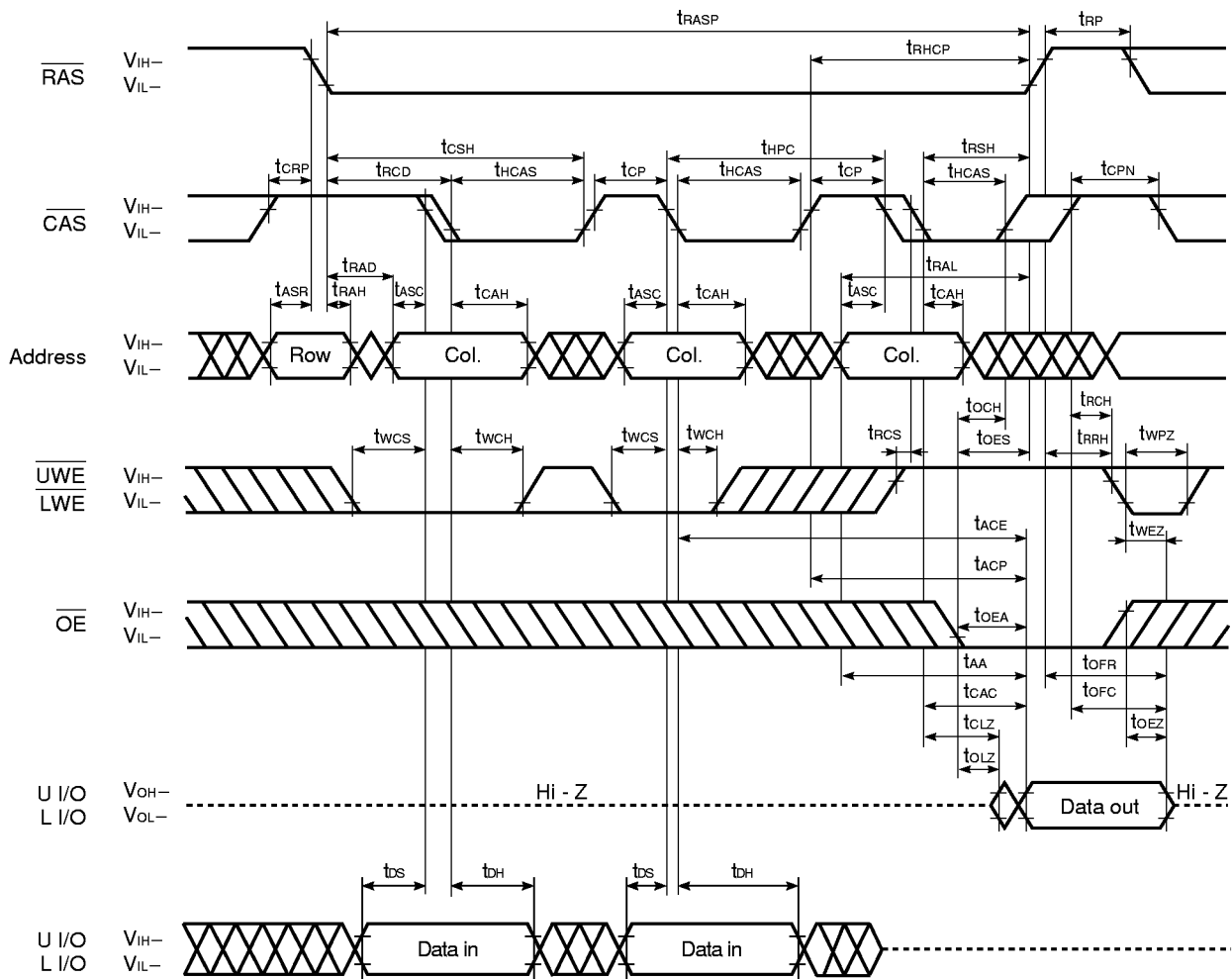

**Remark** In the hyper page mode (EDO), read, write and read modify write cycles are available for each of the consecutive  $\overline{CAS}$  cycles within the same  $\overline{RAS}$  cycle.

**CAS Before RAS Refresh Cycle**

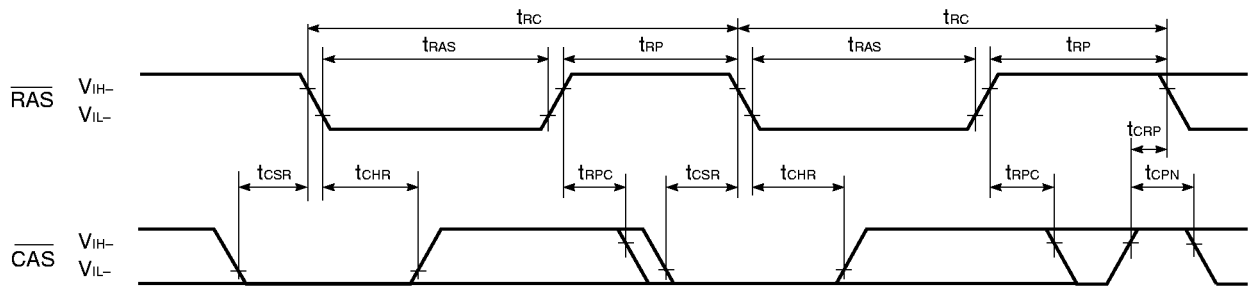

**Remark** Address,  $\overline{UWE}$ ,  $\overline{LWE}$ ,  $\overline{OE}$ : Don't care U I/O, L I/O: Hi-Z

**RAS Only Refresh Cycle**

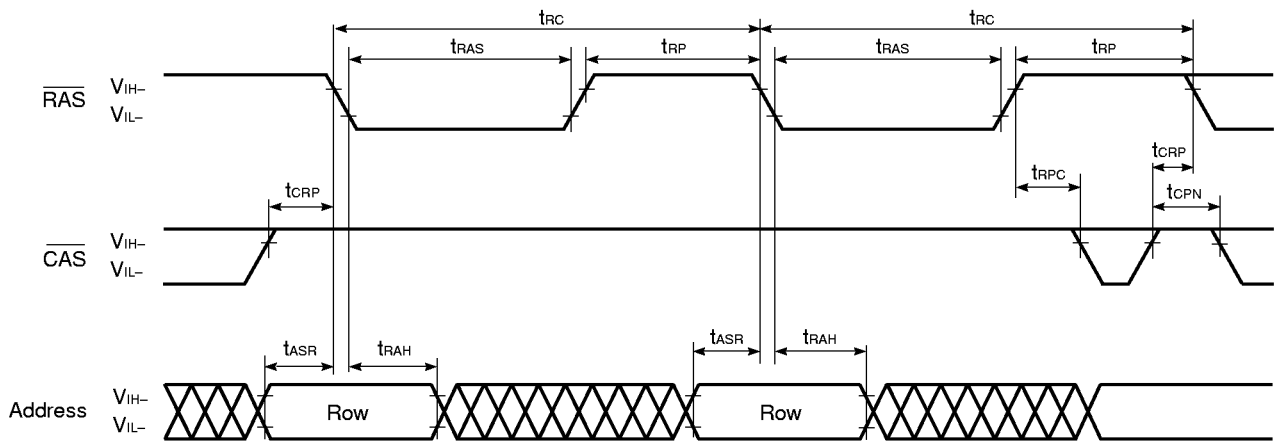

**Remark**  $\overline{UWE}$ ,  $\overline{LWE}$ ,  $\overline{OE}$ : Don't care U I/O, L I/O: Hi-Z

Hidden Refresh Cycle (Read)

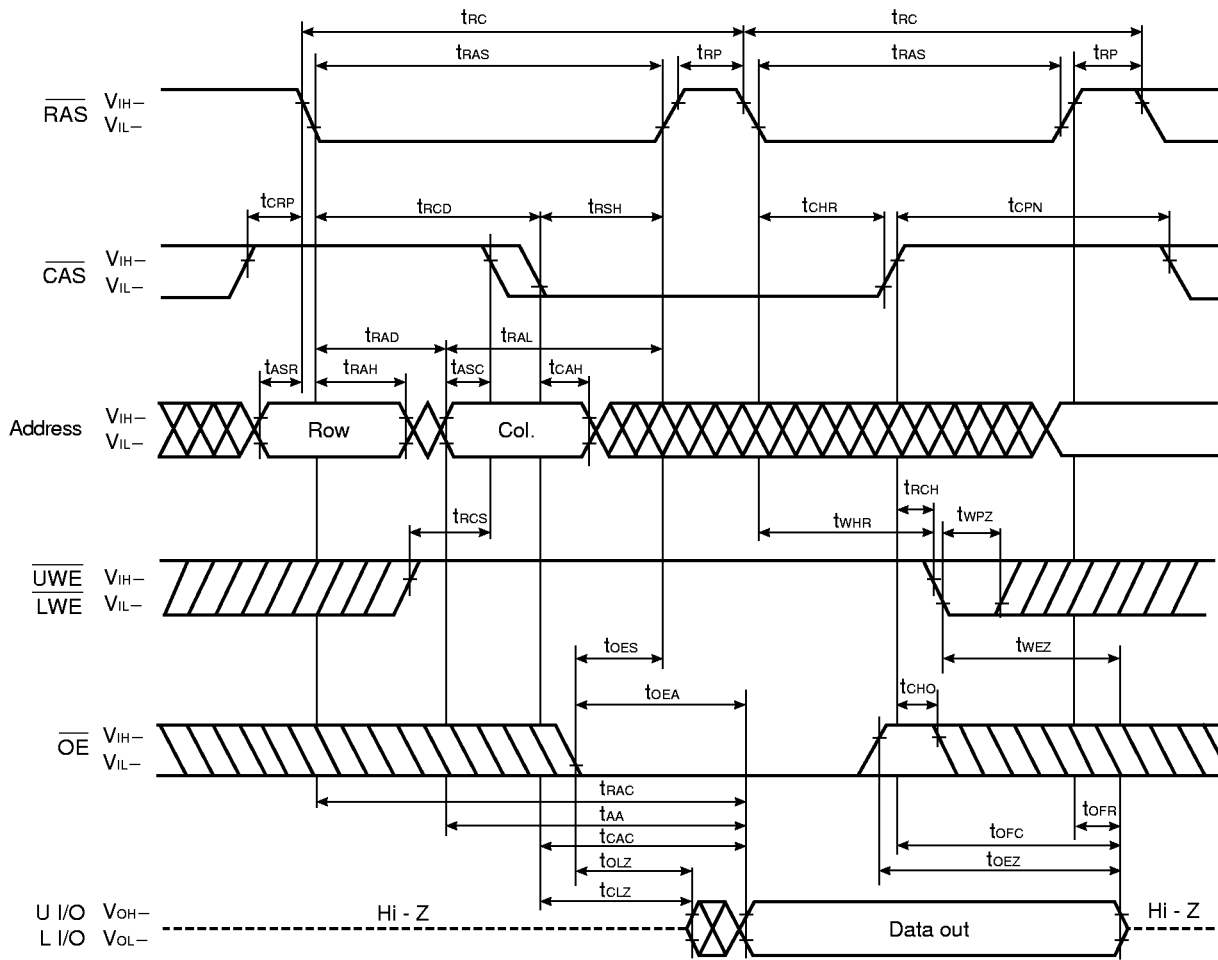

Hidden Refresh Cycle (Write)

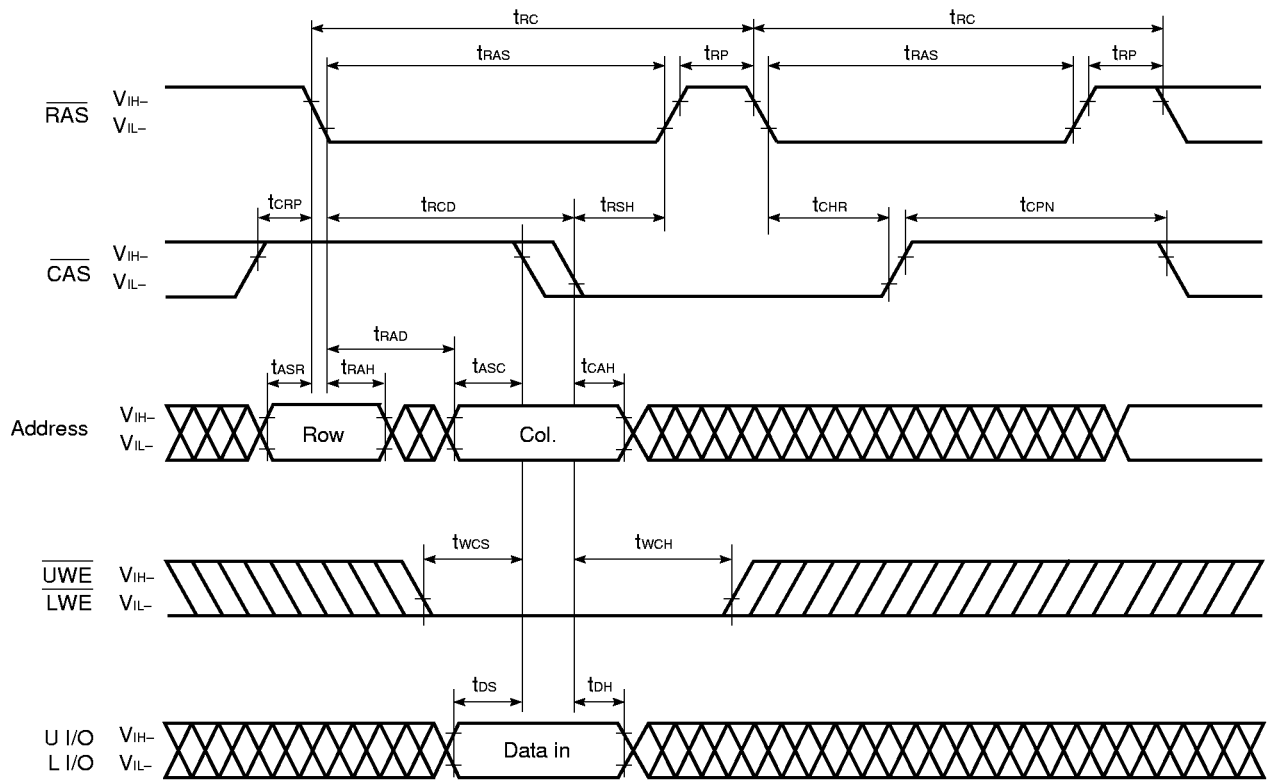

Remark  $\overline{OE}$ : Don't care

Hidden Refresh Cycle (Upper Byte Write)

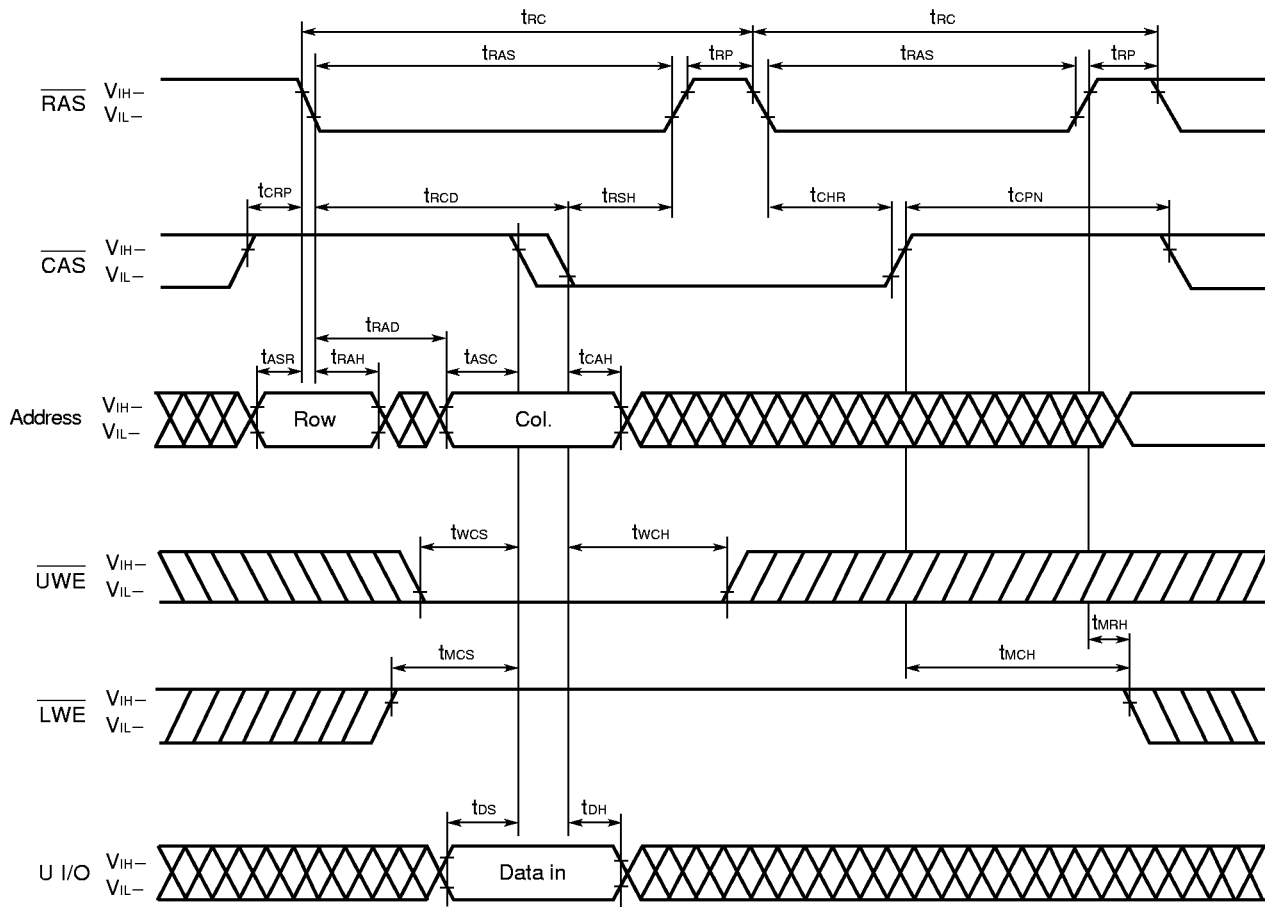

Remark  $\overline{OE}$ , L I/O: Don't care

Hidden Refresh Cycle (Lower Byte Write)

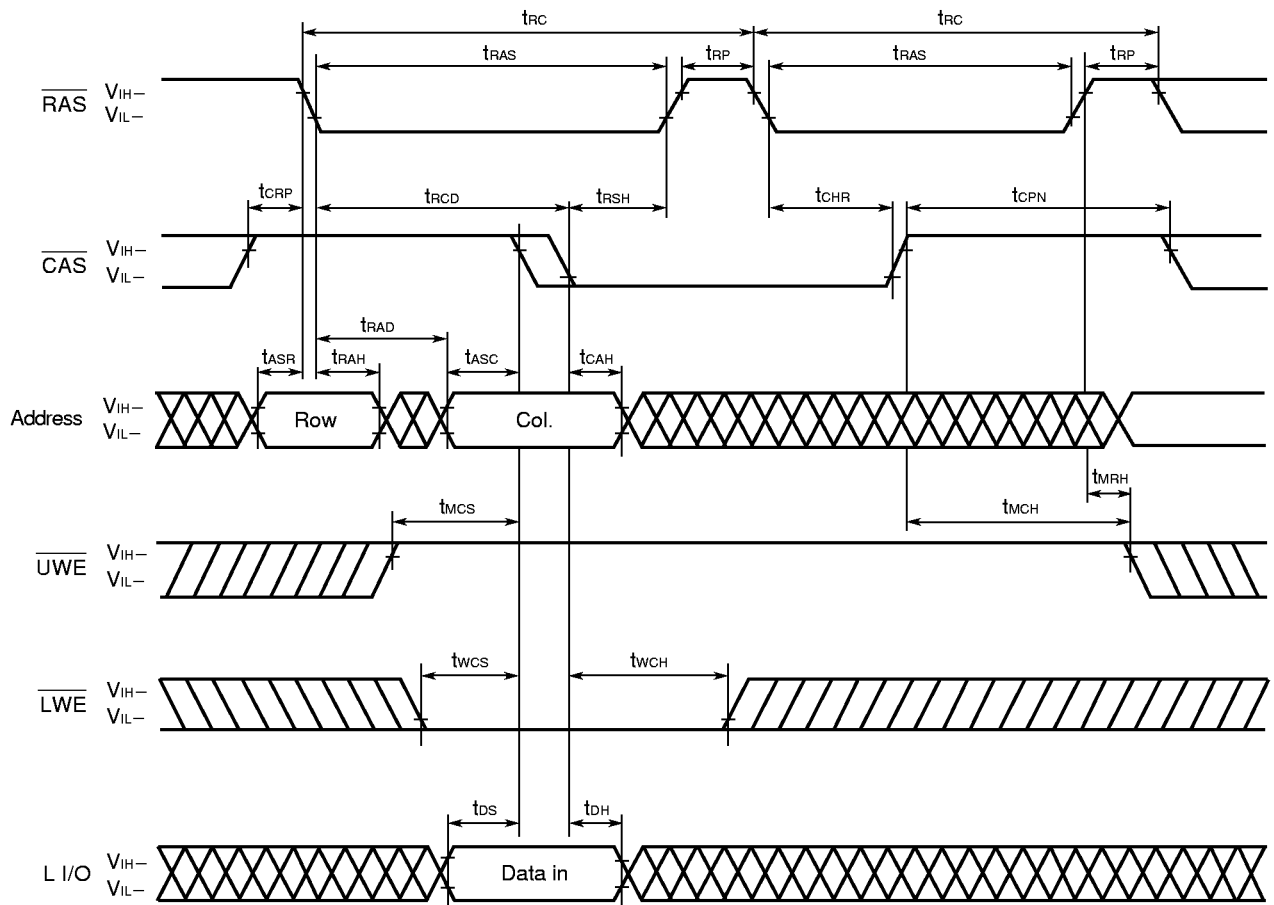

Remark  $\overline{OE}$ , U I/O: Don't care

Package Drawings

44 PIN PLASTIC TSOP(II) (400 mil)

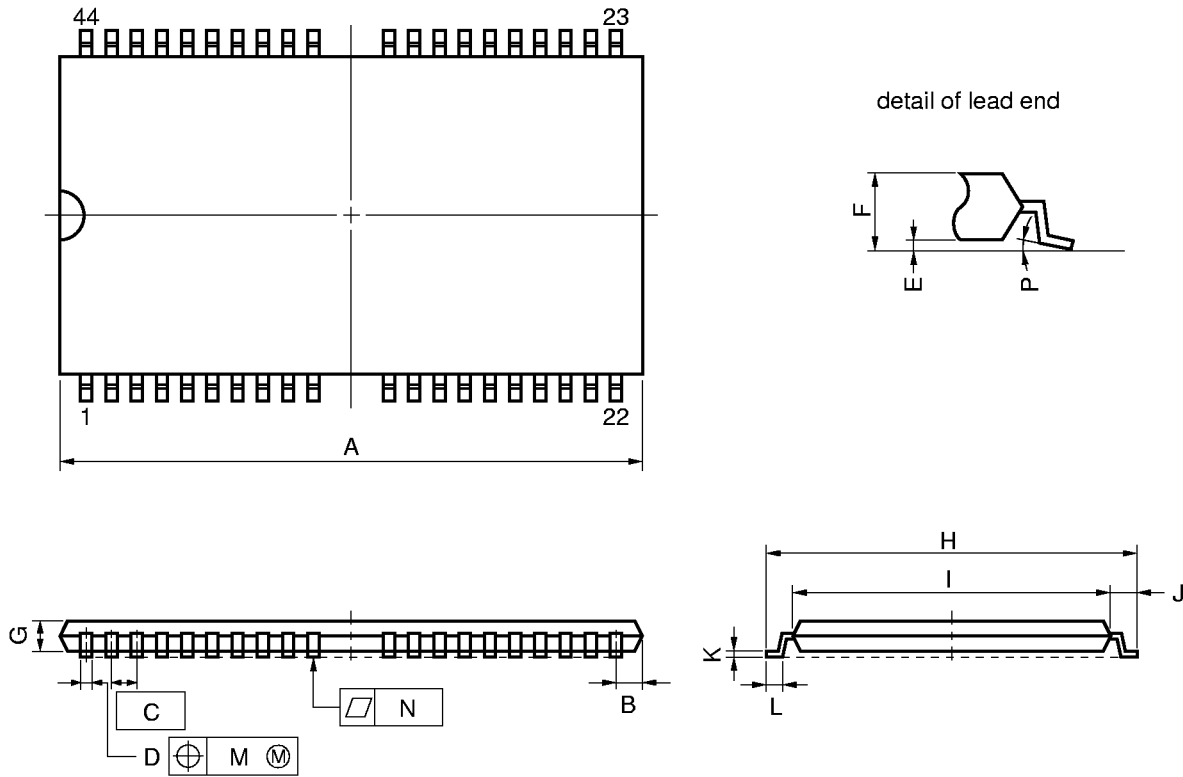

NOTE

Each lead centerline is located within 0.13 mm (0.005 inch) of its true position (T.P.) at maximum material condition.

ITEM	MILLIMETERS	INCHES
A	18.63 MAX.	0.734 MAX.
B	0.93 MAX.	0.037 MAX.
C	0.8 (T.P.)	0.031 (T.P.)
D	$0.32^{+0.08}_{-0.07}$	0.013±0.003
E	0.1±0.05	0.004±0.002
F	1.2 MAX.	0.048 MAX.
G	0.97	0.038
H	11.76±0.2	0.463±0.008
I	10.16±0.1	0.400±0.004
J	0.8±0.2	0.031 <sup>+0.009</sup> <sub>-0.008</sub>
K	$0.145^{+0.025}_{-0.015}$	0.006±0.001
L	0.5±0.1	0.020 <sup>+0.004</sup> <sub>-0.005</sub>
M	0.13	0.005
N	0.10	0.004
P	$3^{\circ+7^{\circ}}$ $-3^{\circ}$	$3^{\circ+7^{\circ}}$ $-3^{\circ}$

S44G5-80-7JF4

40 PIN PLASTIC SOJ (400 mil)

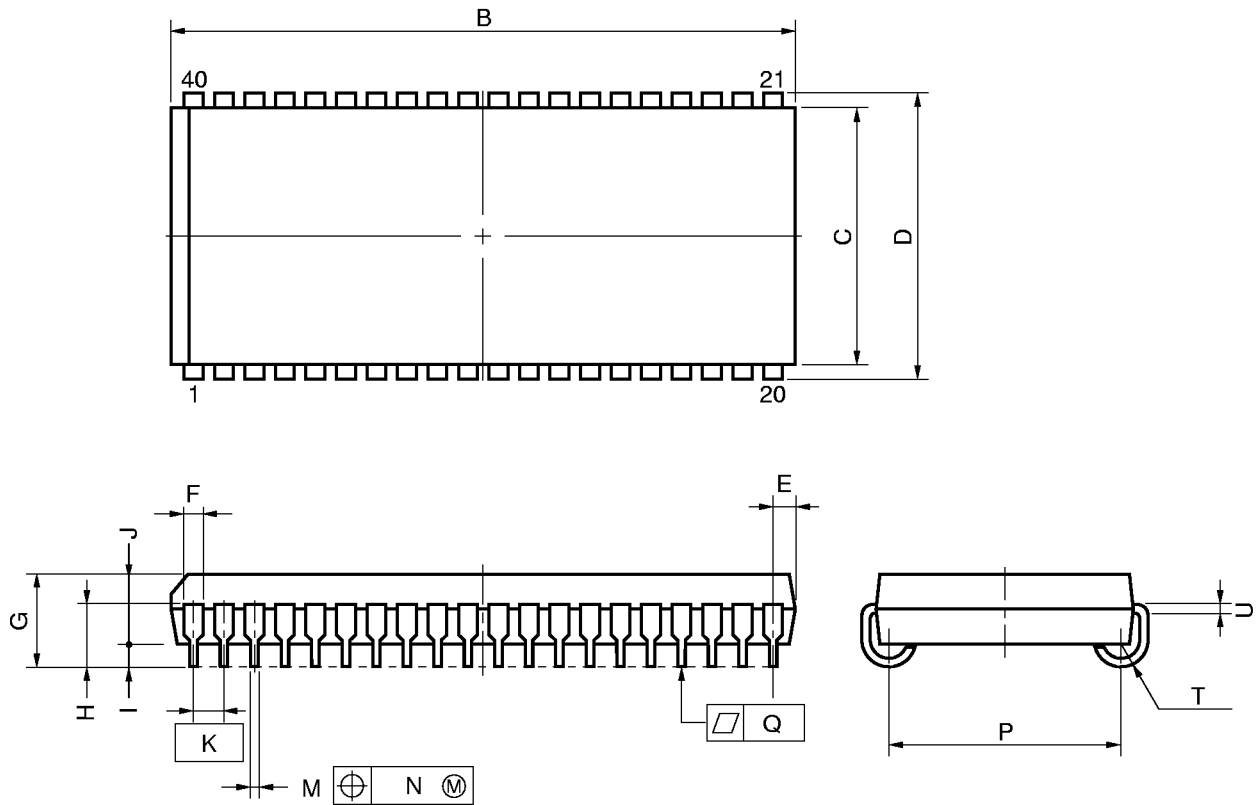

**NOTE**

Each lead centerline is located within 0.12 mm (0.005 inch) of its true position (T.P.) at maximum material condition.

ITEM	MILLIMETERS	INCHES
B	26.29 <sup>+0.2</sup> <sub>-0.35</sub>	1.035 <sup>+0.008</sup> <sub>-0.014</sub>
C	10.16	0.400
D	11.18±0.2	0.440±0.008
E	1.08±0.15	0.043 <sup>+0.006</sup> <sub>-0.007</sub>
F	0.7	0.028
G	3.5±0.2	0.138±0.008
H	2.4±0.2	0.094 <sup>+0.009</sup> <sub>-0.008</sub>
I	0.8 MIN.	0.031 MIN.
J	2.6	0.102
K	1.27(T.P.)	0.050(T.P.)
M	0.40±0.10	0.016 <sup>+0.004</sup> <sub>-0.005</sub>
N	0.12	0.005
P	9.40±0.20	0.370±0.008
Q	0.15	0.006
T	R0.85	R0.033
U	0.20 <sup>+0.10</sup> <sub>-0.05</sub>	0.008 <sup>+0.004</sup> <sub>-0.002</sub>

P40LE-400A-2

★ Recommended Soldering Conditions

The following conditions (see tables below and next page) must be met for soldering conditions of the  $\mu$ PD421175.

For more details, refer to our document “SEMICONDUCTOR DEVICE MOUNTING TECHNOLOGY MANUAL” (C10535E).

Please consult with our sales offices in case other soldering process is used, or in case the soldering is done under different conditions.

Types of Surface Mount Device

$\mu$ PD421175G5-7JF: 44-pin plastic TSOP (II) (400 mil)

Soldering process	Soldering conditions	Symbol
Infrared ray reflow	Peak temperature of package surface: 235 °C or lower, Reflow time: 30 seconds or less (210 °C or higher), Number of reflow processes: MAX. 3 Exposure limit: 7 days <sup>Note</sup> (10 hours pre-baking is required at 125 °C afterwards)	IR35-107-3
VPS	Peak temperature of package: 215 °C or lower, Reflow time: 40 seconds or less (200 °C or higher), Number of reflow processes: MAX. 3 Exposure limit :7 days <sup>Note</sup> (10 hours pre-baking is required at 125 °C afterwards)	VP15-107-3
Partial heating method	Terminal temperature: 300 °C or lower, Time: 3 seconds or lower (Per side of the package).	—————

**Note** Exposure limit before soldering after dry-pack package is opened.  
Storage conditions: 25 °C and relative humidity at 65 % or less.

**Caution** Do not apply more than one soldering method at any one time, except for “Partial heating method”.

μPD421175LE: 40-pin plastic SOJ (400 mil)

Soldering process	Soldering conditions	Symbol
Infrared ray reflow	Peak temperature of package surface: 235 °C or lower, Reflow time: 30 seconds or less (210 °C or higher), Number of reflow processes: MAX. 3 Exposure limit: 7 days <sup>Note</sup> (20 hours pre-baking is required at 125 °C afterwards)	IR35-207-3
VPS	Peak temperature of package: 215 °C or lower, Reflow time: 40 seconds or less (200 °C or higher), Number of reflow processes: MAX. 3 Exposure limit: 7 days <sup>Note</sup> (20 hours pre-baking is required at 125 °C afterwards)	VP15-207-3
Partial heating method	Terminal temperature: 300 °C or lower, Time: 3 seconds or less (Per side of the package).	_____

**Note** Exposure limit before soldering after dry-pack package is opened.  
Storage conditions: 25 °C and relative humidity at 65 % or less.

**Caution** Do not apply more than one soldering method at any one time, except for “Partial heating method”.