

5.5V Wide Temperature Range Capacitors

GREEN CAP

85°C

- It is a category temperature range larger than battery.
- $\phi 13.5$ size can encase up to 0.22F, $\phi 21.5$ size can encase up to 1.0F.
- It excels in rapid charge.
- Ideal for backing up of CMOS IC's, microcomputers, RAM's, RTC's for smart meter, outdoor equipment, auto motive and industrial.

Wide temperature range

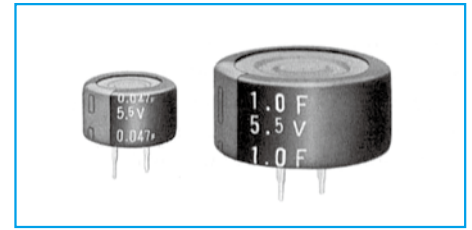

Marking color : White print on an indigo sleeve

Specifications

Item	Performance						
Category temperature range (°C)	-40 to +85						
Tolerance at rated capacitance (%)	-20 to +80						
Internal resistance at 1 kHz	Rated capacitance (F)	0.047	0.1	0.22	0.47	0.68	1
	Internal resistance (Ω Max.)	40	40	40	20	20	20
Characteristics at high and low temperature	Percentage of capacitance change	Within $\pm 30\%$ of the value at 20°C					
	Internal resistance	-40°C : Seven times or less of the value at 20°C 85°C : Five times or less of the value at 20°C					
Endurance (85°C)	Test time	1000 hours					
	Percentage of capacitance change	Within $\pm 30\%$ of the initial measured value					
	Internal resistance	Four times or less of the initial specified value					
Shelf life (85°C)	Test time : 1000 hours ; Same as endurance.						
Applicable standards	Conforms to JIS C5160-1 (IEC 62391-1)						

Outline Drawing

Unit : mm

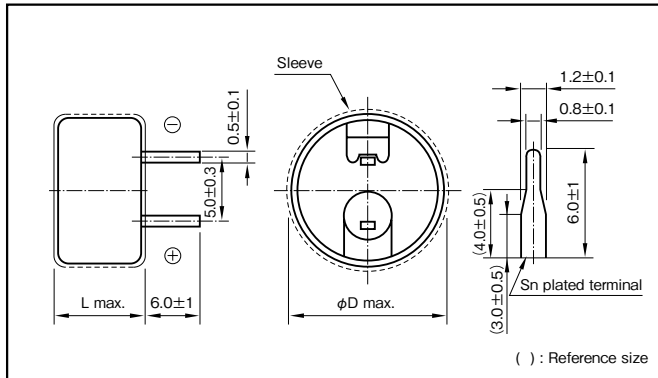

Part numbering system (example : 5.5V0.22F)

DHL	—	5R5	D	224	T
Series code		Rated voltage symbol		Rated capacitance symbol	

Part number is refer to following table.

Standard Ratings

Max. operating voltage (V)	Rated capacitance (F)	ELNA Parts No.	$\phi D \times L$ (mm)
5.5	0.047	DHL-5R5D473T	13.5×9.5
5.5	0.1	DHL-5R5D104T	13.5×9.5
5.5	0.22	DHL-5R5D224T	13.5×9.5
5.5	0.47	DHL-5R5D474T	21.5×9.5
5.5	0.68	DHL-5R5D684T	21.5×9.5
5.5	1	DHL-5R5D105T	21.5×9.5

NOTE : Design, Specifications are subject to change without notice. It is recommended that you shall obtain technical specifications from ELNA to ensure that the component is suitable for your use.