

REVISIONS			
REV.	DESCRIPTION	ECN NO.	DATE
01	FIRST RELEASE FOR A2008-11133	N/A	12/10/08

PAGE 4 IS FOR INTERNAL USE

PART NUMBER		PART DESCRIPTION		TITLE											
835-01076		Standard version, with Lead(Pb)		TRANSFORMER, FLYBACK, SMT, 10 PIN											
835-01076F		RoHS compliant per EU Directive 2002/95/EC(without exemption of solder content)													
<p align="center"><u>WARNING !</u></p> <p>ALL SHEETS OF THIS DOCUMENT ARE CONTROLLED DOCUMENTATION AND ARE NOT TO BE RELEASED OUTSIDE OF E&E OR ITS SUB-CONTRACTORS WITHOUT AUTHORIZATION.</p>		UNLESS OTHERWISE SPECIFIED, DIMENSIONS ARE IN INCH/mm.		APPROVALS											
		<p align="center"><u>TOLERANCE ARE:</u></p> <table border="0"> <tr> <td>INCH</td> <td>mm</td> <td>ANGLE</td> </tr> <tr> <td>.XXX ± .005</td> <td>.XX ± .13</td> <td>X.X ± 0.3</td> </tr> <tr> <td>.XX ± .02</td> <td>.X ± .5</td> <td>X. ± 1</td> </tr> </table>		INCH	mm	ANGLE	.XXX ± .005	.XX ± .13	X.X ± 0.3	.XX ± .02	.X ± .5	X. ± 1	DATE		 <p>E & E Magnetic Products Ltd.</p>
		INCH	mm	ANGLE											
		.XXX ± .005	.XX ± .13	X.X ± 0.3											
		.XX ± .02	.X ± .5	X. ± 1											
DRAWN BY		W.P. CHENG		12/10/08											
PROJ. ENG		W.P. CHENG		12/10/08											
APPROVED BY		V. TSUI		12/10/08											
Q.A.		C.M. TSUI		12/10/08											
DRAWING NO./MODEL		835-01076		REV											
SCALE		DO NOT SCALE		1 OF 4											

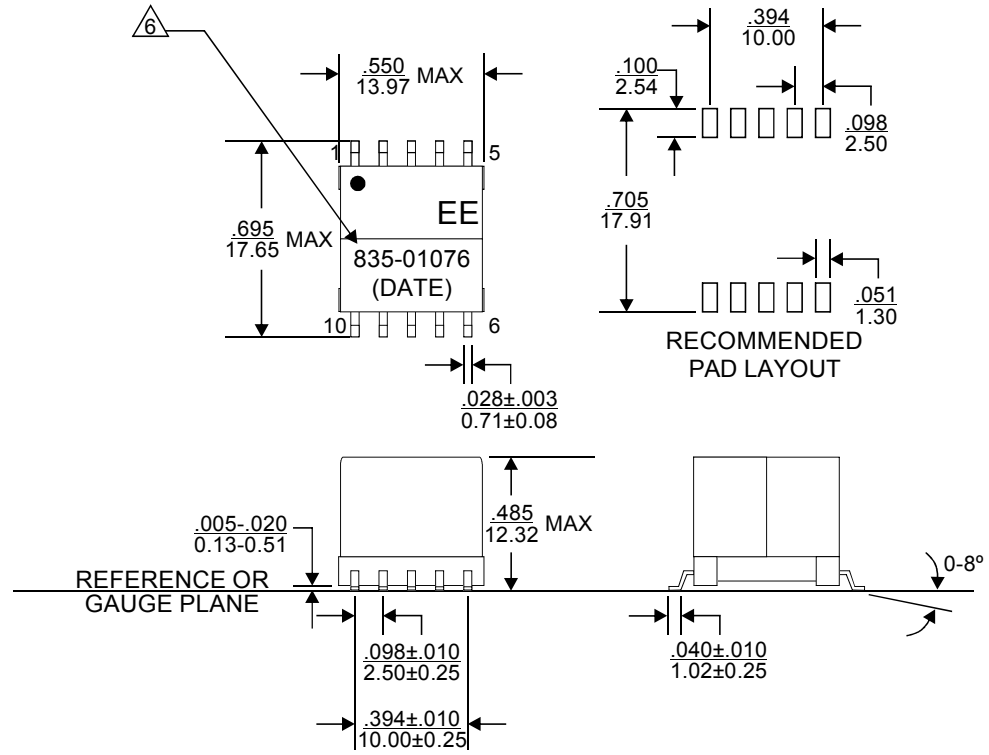

1. Dimension are specified in $\frac{\text{inches}}{\text{mm}}$ with higher precedence in mm.
 2. Unless otherwise specified, all tolerance are $\pm \frac{.010}{.25}$.
 3. Coplanarity: $\frac{.004}{0.10}$ max.
 4. "(DATE)" includes at least the manufacturing date code(in YYWW format) plus two character country code.
 5. Dimensions are to be measured in accordance with JEDEC standard 95-1.
- ⚠ For RoHS compliant version, 835-01076F, the part will be marked with "835-01076F", instead of "835-01076".

MECHANICAL OUTLINE

 E & E Magnetic Products Ltd.		
DRAWING NO./MODEL		REV
835-01076		01
SCALE	PAGE	OF
DO NOT SCALE	2	4

ELECTRICAL SPECIFICATION @25°C:

PARAMETERS	UNIT	LIMITS
Turns Ratio(3-4):(8/7-10/9)	-	1 : 0.156 ± 2%
Turns Ratio(3-4):(2-1)	-	1 : 0.50 ± 2%
Polarity	-	Per Schematic
Inductance, Ls(3-4)@100kHz, 0.1Vrms, 0Adc	uH	62.4 ± 10%
Inductance, Ls(3-4)@100kHz, 0.1Vrms, 1Adc	uH	50 Min
LL(3-4), short 8-7-10-9-2-1@100kHz, 0.1Vrms	uH	1.0 Max
DCR(3-4)	mΩ	150 Max
DCR(2-1)	mΩ	500 Max
DCR(8/7-10/9)	mΩ	9 Max
HIPOT(3-4-2-1):(8-7-10-9), 1 minute	VAC	1500 Min

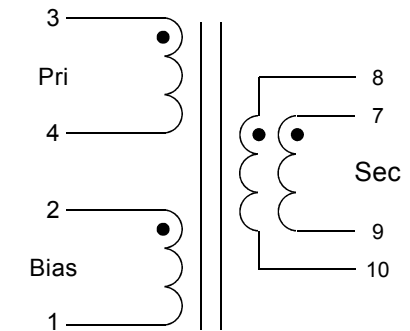

SCHEMATIC

- Operating temperature range: -40°C to +85°C. The part temperature (ambient temperature + temperature rise) should not exceed the upper limit of the operating temperature under worst case operating conditions. Circuit design, component placement, PWB trace size and thickness, airflow and other cooling provisions all affect the part temperature. Part temperature should be verified in the end application.
- Output of the secondary is with the windings connected in parallel. Bias winding output is 12V, 20mA.



E & E Magnetic Products Ltd.

DRAWING NO./MODEL		REV
835-01076		01
SCALE	PAGE	OF
DO NOT SCALE	3	4