

9-Bit Parity Generator/Checker

The LS280 is a bipolar, NPN, sealed-junction, silicon integrated circuit. It is manufactured in low-power Schottky technology and is available in a wire-bonded, 14-pin plastic DIP or surface mount package.

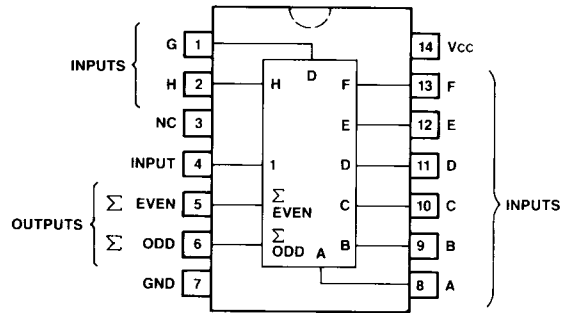

Logic Diagram

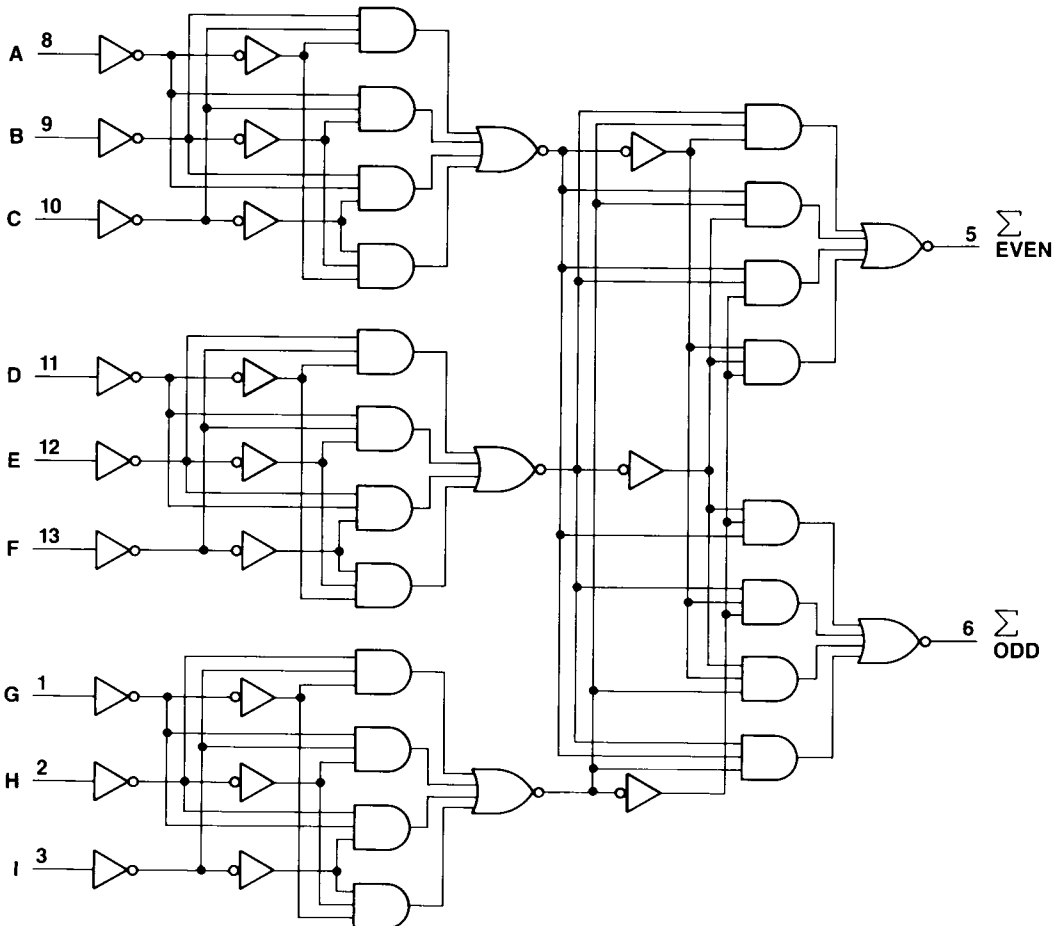

LS280 (Preliminary)

Electrical Characteristics

VCC = 5.0 ±0.5 V, TA = -55 to +125°C (WA-LS)

VCC = 5.0 ±0.25 V, TA = 0 to 70°C (WP90352L2)

VCC = 5.0 ±0.5 V, TA = -40 to +85°C (WP91400L3)

Parameter	Symbol	WA-LS		WP		Units
		Min	Max	Min	Max	
Output Voltage, VCC = 4.5 V (WA-LS), 4.75 V (WP)						
Low, IOL = 4.0 mA	VOL	—	0.4	—	0.4	V
IOL = 8.0 mA	VOL	—	0.5	—	0.5	V
High, IOH = -0.4 mA	VOH	2.5	—	2.7	—	V
Input Voltage, VCC = 4.5 V (WA-LS), 4.75 V (WP)						
Low	VIL	—	0.7	—	0.8*	V
High	VIH	2.0	7.5	2.0	5.5	V
Clamp, IIN = -18.0 mA	VIK	—	-1.5	—	-1.5	V
Input Current, VCC = 5.5 V (WA-LS), 5.25 V (WP)						
Low, VIL = 0.4 V	IIL	—	-0.4	—	-0.4	mA
High, VIH = 2.7 V	IIH	—	20.0	—	20.0	μA
@ Vi max, Vi = 7.0 V (WA-LS), 5.5 V (WP)	II	—	0.1	—	0.1	mA
Output Current, VCC = 5.5 V (WA-LS), 5.25 V (WP)						
Short-Circuit	Ios	-20.0	-100.0	-20.0	-100.0	mA
Supply Current, VCC = 5.5 V (WA-LS), 5.25 V (WP)	Icc	—	27.0	—	27.0	mA

* WP91400L3: VIL = 0.7 V

Timing Characteristics

VCC = 5.0 V, TA = 25°C, CL = 15 pF

Parameter	Symbol	WA-LS		WP		Units
		Min	Max	Min	Max	
Propagation Delay						
Data to Output (Σ Even)						
Low-to-High	tPLH	—	50.0	—	50.0	ns
High-to-Low	tPHL	—	45.0	—	45.0	ns
Data to Output (Σ Odd)						
Low-to-High	tPLH	—	35.0	—	35.0	ns
High-to-Low	tPHL	—	50.0	—	50.0	ns

Maximum Ratings

Power supply voltage (VCC).....	7.0 V
Operating temperature (TA).....	WA-LS: -55 to +125°C WP90352L2: 0 to 70°C WP91400L3: -40 to +85°C
Storage temperature (T _{stg}).....	-65 to +150°C

Maximum ratings are defined as the limiting conditions that the user can apply to the device under all variations of circuit and environmental conditions. If any rating is exceeded, permanent damage to the device may result.

Bonding or soldering of the external leads of this device can be performed safely at temperatures up to 300°C.