



Micro Commercial Components
 21201 Itasca Street Chatsworth
 CA 91311
 Phone: (818) 701-4933
 Fax: (818) 701-4939

BC817-16 THRU BC817-40

NPN Small Signal Transistor 310mW

Features

- Ideally Suited for Automatic Insertion
- 150°C Junction Temperature
- For Switching and AF Amplifier Applications
- Epitaxial Planar Die Construction

Mechanical Data

- Case: SOT-23, Molded Plastic
- Terminals: Solderable per MIL-STD-202, Method 208
- Polarity: See Diagram
- Weight: 0.008 grams (approx.)
- Marking: BC817-16 6A
 BC817-25 6B
 BC817-40 6C

Maximum Ratings @ 25°C Unless Otherwise Specified

Charateristic	Symbol	Value	Unit
Collector-Emitter Voltage	V_{CEO}	45	V
Emitter-Base Voltage	V_{EBO}	5	V
Collector Current	I_C	800	mA
Peak Collector Current	I_{CM}	1000	mA
Peak Emitter Current	I_{EM}	1000	mA
Power Dissipation@ $T_s=50^\circ\text{C}$ (Note1)	P_d	310	mW
Operating & Storage Temperature	T_j, T_{STG}	-55~150	°C

Note: 1. Device mounted on Ceramic Substrate 0.7mm X 2.5cm² area

SOT-23

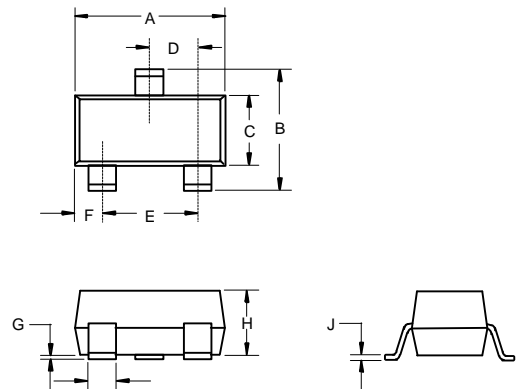

DIM	INCHES		MM		NOTE
	MIN	MAX	MIN	MAX	
A	.110	.120	2.80	3.04	
B	.083	.098	2.10	2.64	
C	.047	.055	1.20	1.40	
D	.035	.041	.89	1.03	
E	.070	.081	1.78	2.05	
F	.018	.024	.45	.60	
G	.0005	.0039	.013	.100	
H	.035	.044	.89	1.12	
J	.003	.007	.085	.180	
K	.015	.020	.37	.51	

Suggested Solder Pad Layout

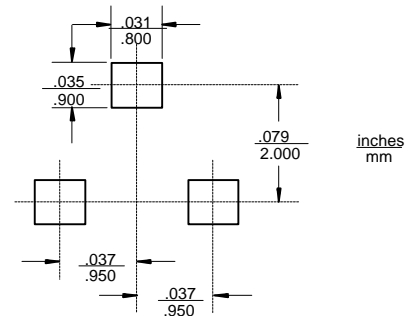

BC817-16 thru BC817-40



Electrical Characteristics

@25°C unless otherwise specified

Characteristic	Symbol	Min	Max	Unit	Test Condition
DC Current Gain	Current Gain Group -16 -25 -40	100	250	—	$V_{CE} = 1.0V, I_C = 100mA$
		160	400		$V_{CE} = 1.0V, I_C = 300mA$
	Current Gain Group -16 -25 -40	250	600	—	
		60	—		
		100	—		
		170	—		
Thermal Resistance, Junction to Substrate Backside	$R_{\theta SB}$	—	320	K/W	Note 1
Thermal Resistance, Junction to Ambient Air	$R_{\theta JA}$	—	400	K/W	Note 1
Collector-Emitter Saturation Voltage	$V_{CE(SAT)}$	—	0.7	V	$I_C = 500mA, I_B = 50mA$
Base-Emitter Voltage	V_{BE}	—	1.2	V	$V_{CE} = 1.0V, I_C = 300mA$
Collector-Emitter Cutoff Current	I_{CES}	—	100	nA	$V_{CE} = 45V$
		—	5.0	μA	$V_{CE} = 25V, T_J = 150^\circ C$
Emitter-Base Cutoff Current	I_{EBO}	—	100	nA	$V_{EB} = 4.0V$
Gain Bandwidth Product	f_T	100	—	MHz	$V_{CE} = 5.0V, I_C = 10mA, f = 50MHz$
Collector-Base Capacitance	C_{CBO}	—	12	pF	$V_{CB} = 10V, f = 1.0MHz$

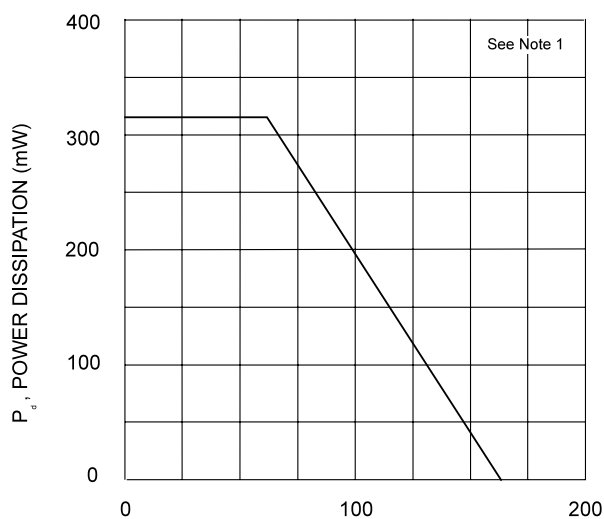

T_{sB} , SUBSTRATE TEMPERATURE (°C)

Fig. 1, Power Derating Curve

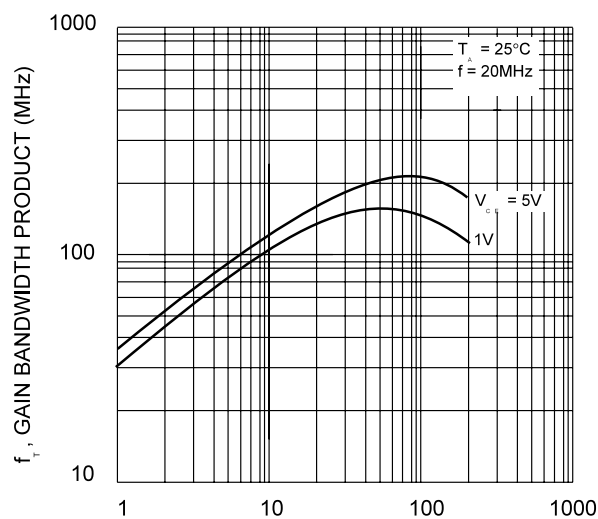

I_C , COLLECTOR CURRENT (mA)

Fig. 2, Gain-Bandwidth Product vs Collector Current

BC817-16 thru BC817-40

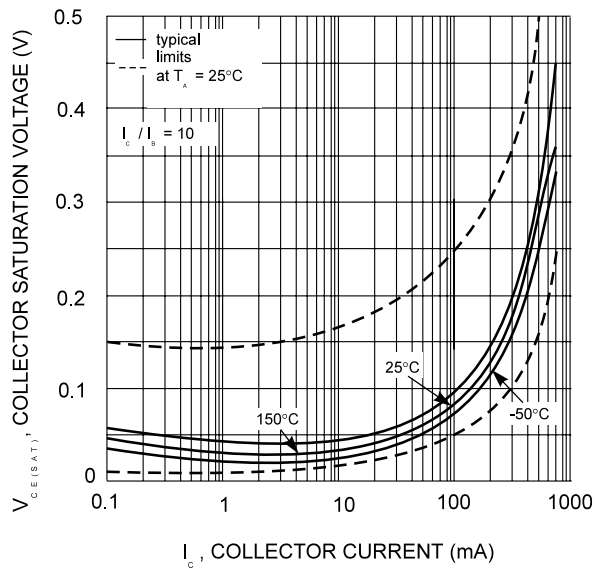

Fig. 3, Collector Sat. Voltage vs Collector Current

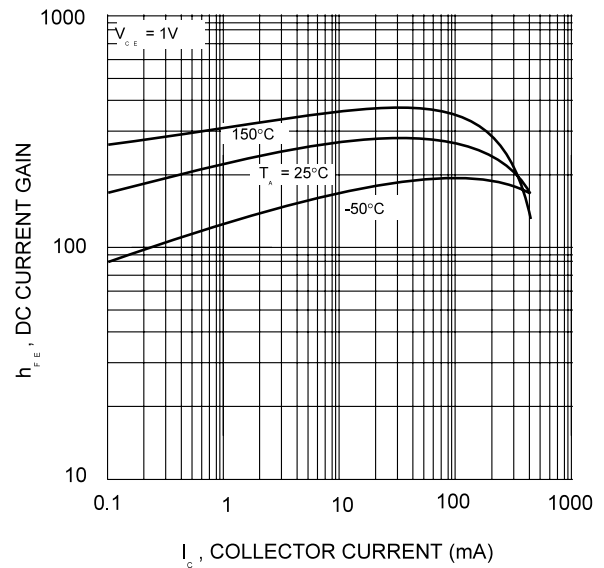

Fig. 4, DC Current Gain vs Collector Current

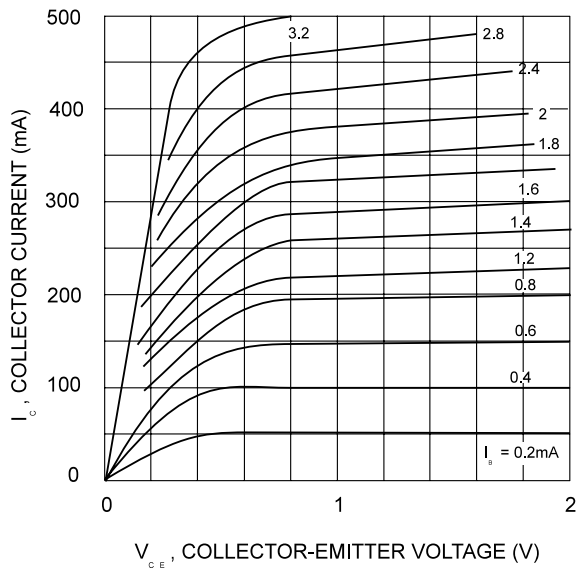

Fig. 5, Typical Emitter-Collector Characteristics

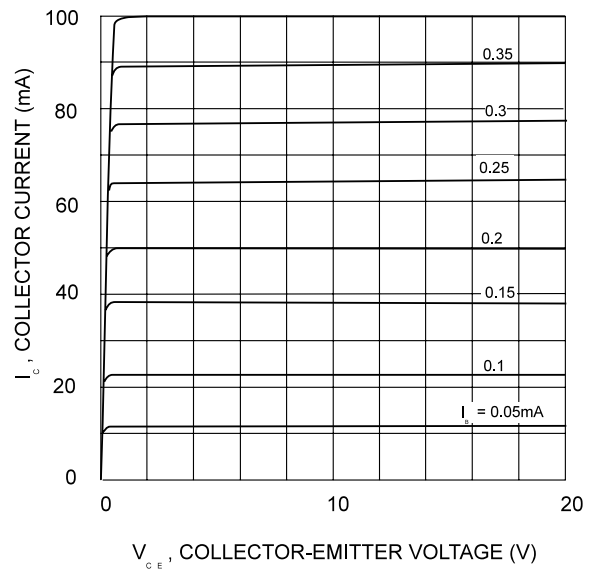

Fig. 6, Typical Emitter-Collector Characteristics