

Features

- Low Phase Noise
- Low power consumption
- Output: HCMOS, PECL, True Sinewave
- Tight Tolerances
- Frequency range ¹ of 50 - 160 MHz
- Standard Frequencies : 50, 50.4, 77.76, 80, 98.304, 100, 122.88, 125, 155.52, 156.25 MHz

Applications

- Test Equipment
- Communication Equipment
- Military
- Industrial Application

Performance Specifications

Frequency Stabilities¹ (Standard TCXO)

Parameter	Min	Typical	Max	Units	Condition	Options ³
vs. operating temperature range (referenced to +25°C)	-1		+1	ppm	-40 to +85°C	
	-0.5		+0.5	ppm	-40 to +85°C	
	-1		+1	ppm	-20 to +70°C	
	-0.28		-0.28	ppm	-20 to +70°C	
Initial tolerance	-1		+1	ppm	at time of shipment, nominal EFC V _S ±5% static Load ±10% static after 30 days of operation	
vs. supply voltage change	-0.2		+0.2	ppm		
vs. load change	-0.1		+0.1	ppm		
vs. aging / year	-1		+1	ppm		

Frequency Stabilities¹ (Stratum 3 TCXO)

Parameter	Min	Typical	Max	Units	Condition	Options ³
vs. operating temperature range (referenced to +25°C)	-0.8		+0.8	ppm	-40 to +85°C	
	-0.28		+0.28	ppm	-40 to +85°C	
	-0.8		+0.8	ppm	-20 to +70°C	
	-0.28		-0.28	ppm	-20 to +70°C	
Initial tolerance	-1		+1	ppm	at time of shipment, nominal EFC V _S ±5% static Load ±10% static after 30 days of operation	
vs. supply voltage change	-0.2		+0.2	ppm		
vs. load change	-0.1		+0.1	ppm		
vs. aging / year	-1		+1	ppm		
vs. aging / 20 years	-2.5		+2.5	ppm	Note: Stratum 3 per GR-1244-CORE: <±4.6ppm for all causes and 20years aging Holdover: <±0.37ppm over 24 hours	
Over all tolerance	-4.6		+4.6	ppm		

Performance Specifications

Supply Voltage (Vs)						
Parameter	Min	Typical	Max	Units	Condition	
Supply voltage (standard)	3.135	3.3	3.465	VDC		
Supply voltage (Option)	4.75	5	5.25	VDC		
Current consumption			35 100	mA mA	steady state @25°C, HCMOS, Clipped sinewave steady state @25°C, PECL	
RF Output						
Signal [standard]	HCMOS					
Load	13.5	15	16.5	pF		
Signal Level (Vol)			0.3	VDC	with Vs=3.3V and 15pF Load	
Signal Level (Voh)	2.6				with Vs=3.3V and 15pF Load	
Duty Cycle	40		60	%	@ (Voh-Vol)/2	
Rise and Fall time			5	ns	@15 pF 10 to 90 %	
Signal [Option]	PECL				Available > 40MHz only	
Load	45	50	55	Ohm	to Vs - 2V	
Rise and Fall time			1	ns	20 to 80%	
Duty Cycle	45		55	%		
Signal [Option]	True Sinewave					
Load	45	50	55	Ohm		
Output power	0	3	6	dBm		
Frequency Tuning (EFC)						
Tuning Range	Fixed TCXO; No adjust					Option
Tuning Range	±8 ±5			ppm ppm	Standard Version Stratum 3 Version	
Linearity	<10%					
Tuning Slope	Positive					
Control Input Impedance	10			kOhm		
Control Voltage Range	0.3	1.65	3.0	VDC	with Vs=3.3V	
Additional Parameters						
Phase Noise ²		-78		dBc/Hz	10 Hz	@ 100MHz LVPECL 3.3 V
		-104		dBc/Hz	100 Hz	
		-134		dBc/Hz	1 kHz	
		-147		dBc/Hz	10 kHz	
		-152		dBc/Hz	100 kHz	
		-152		dBc/Hz	1 MHz	
Jitter		0.2		ps RMS	@ 12 kHz to 20 MHz	
Phase Noise ²		-73		dBc/Hz	10 Hz	@ 100MHz HCMOS 3.3V
		-102		dBc/Hz	100 Hz	
		-132		dBc/Hz	1 kHz	
		-150		dBc/Hz	10 kHz	
		-158		dBc/Hz	100 kHz	
		-160		dBc/Hz	1 MHz	
Jitter		0.1		ps RMS	@ 12 kHz to 20 MHz	
Phase Noise ²		-76		dBc/Hz	10 Hz	@ 100MHz Sine 3.3V
		-102		dBc/Hz	100 Hz	
		-132		dBc/Hz	1 kHz	
		-151		dBc/Hz	10 kHz	
		-155		dBc/Hz	100 kHz	
		-157		dBc/Hz	1 MHz	
Jitter		0.1		ps RMS	@ 12 kHz to 20 MHz	

Absolute Maximum Ratings

supply voltage (Vs)		6.0	V	with Vs=3.3 VDC
Output Load		50	pF	
Operable Temperature Range	-40	+85	°C	
Storage Temperature Range	-40	+105	°C	

Typical Performance

Phase Noise

TX-500 @ 100MHz LVPECL

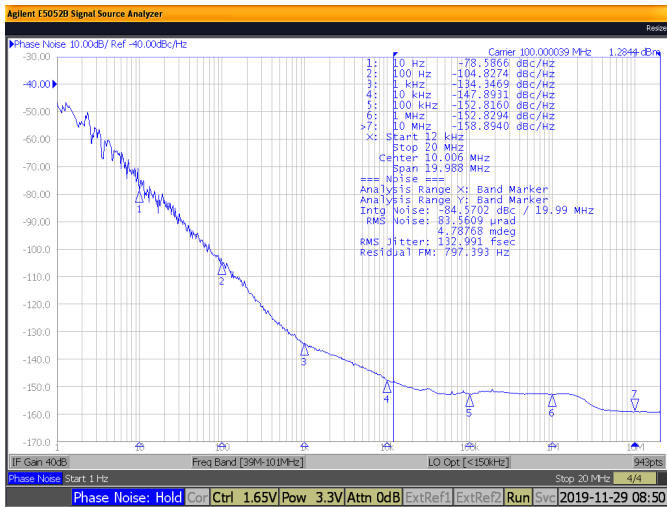

Phase Noise

TX-500 @ 100MHz Sinewave

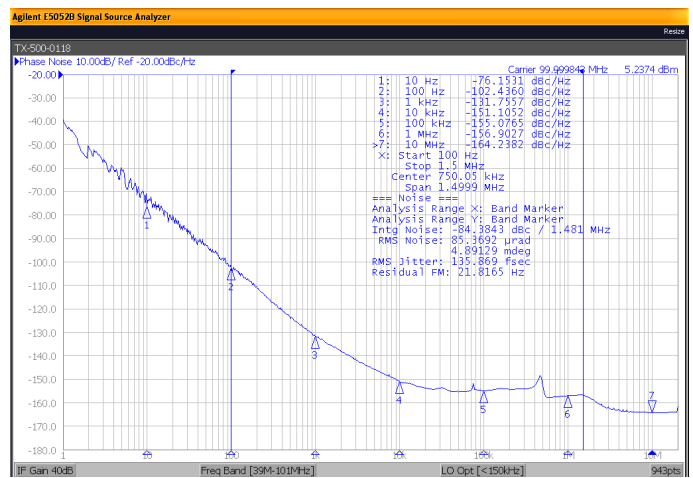

Phase Noise

TX-500 @ 100MHz HCMOS

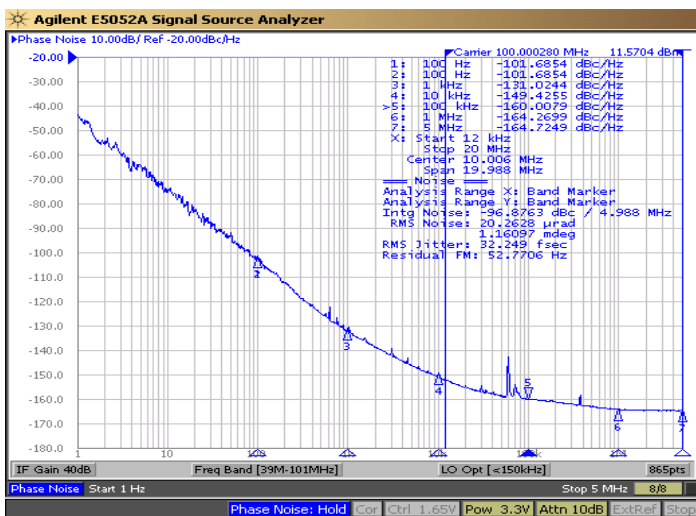

Phase Noise

Outline Drawing / Enclosure

TX-500	
Type	Height "H" in mm
G214B [Standard]	5.9 (metal cap)
G214C [Option]	2.8 (metal cap)
G286B	5.9 (black plastic cap)
G371	3.8 (black plastic cap)

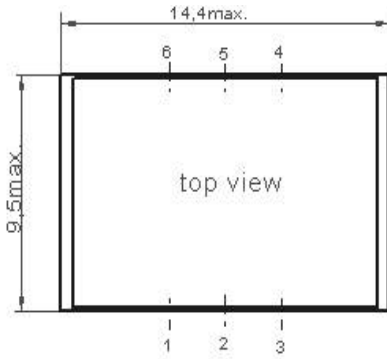

G 214

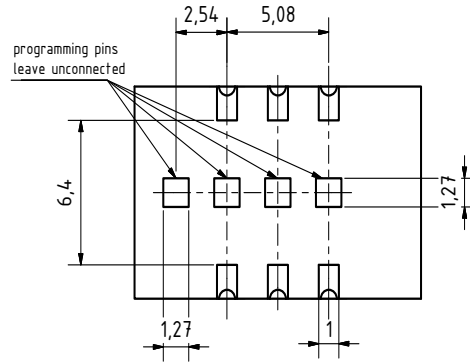

G286B
G371

land pattern recommendation

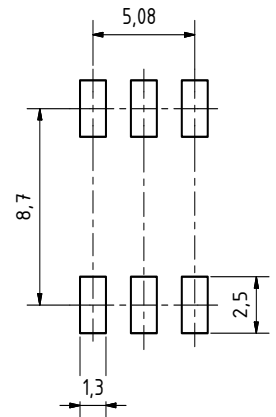
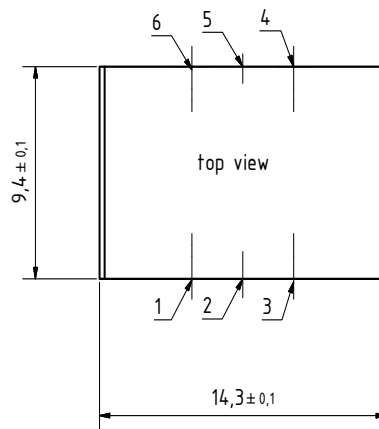
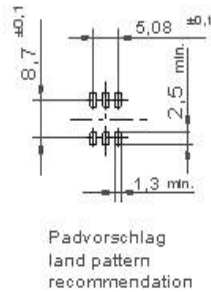
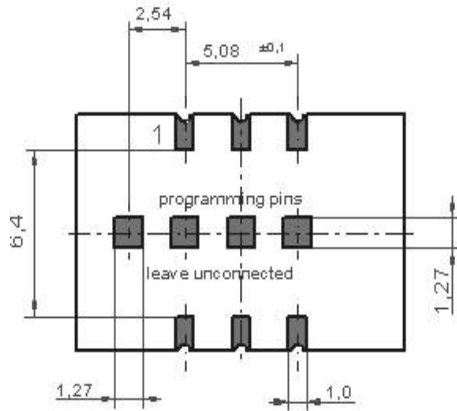
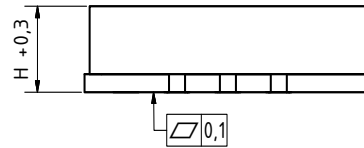
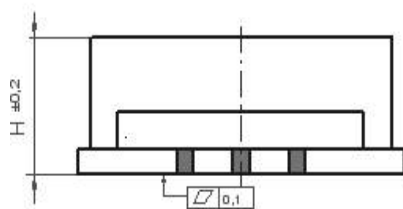

Pin Connections (CMOS, True Sinewave)	
1	Control Voltage Input (Vc) / N.C.
2	N.C.
3	Ground (Case)
4	RF-Output
5	N.C.
6	Supply Voltage Input (Vs)

Pin Connections (PECL)	
1	Control Voltage Input (Vc) / N.C.
2	N.C.
3	Ground (Case)
4	RF-Output
5	RF-Output_complementary
6	Supply Voltage Input (Vs)

Standard Shipping Method (TX-500)

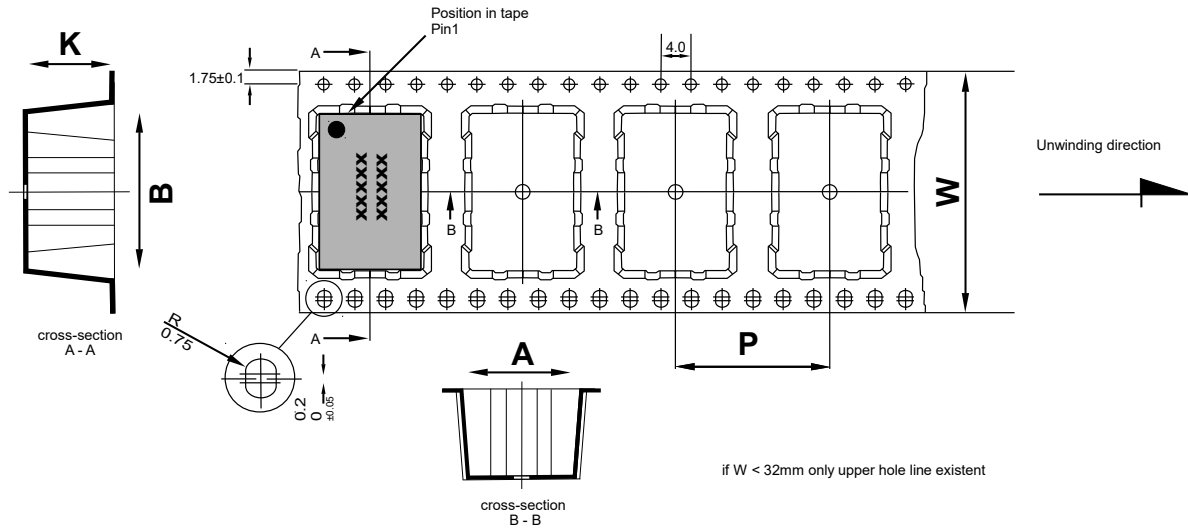

Dimension in mm:
 A, B and K are dependent upon component dimensions
 production tolerance complying DIN IEC 286-3

All dimensions in millimeters unless otherwise stated

Enclosure Type	Tape Width W (mm)	Quantity per meter	Quantity per reel	Dimension P
G214B / G286C	24	83.3	850	12
G214C	24	83.3	1700	12

Recommended Reflow Profile

TP: max 250°C (@ solder joint, customer board level)

T_p: max: 10...30 sec

Additional Information:

This SMD oscillator has been designed for pick and place reflow soldering

SMD oscillators must be on the top side of the PCB during the reflow process.

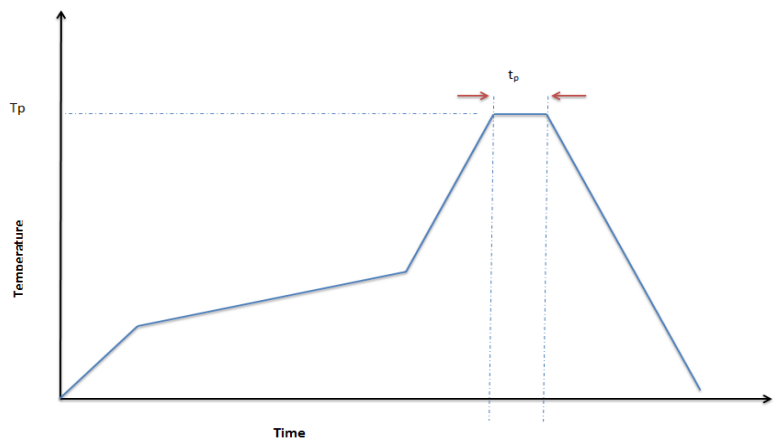

Ordering Information

TX - 500 0 - E A E - 507 0 - 100M000000

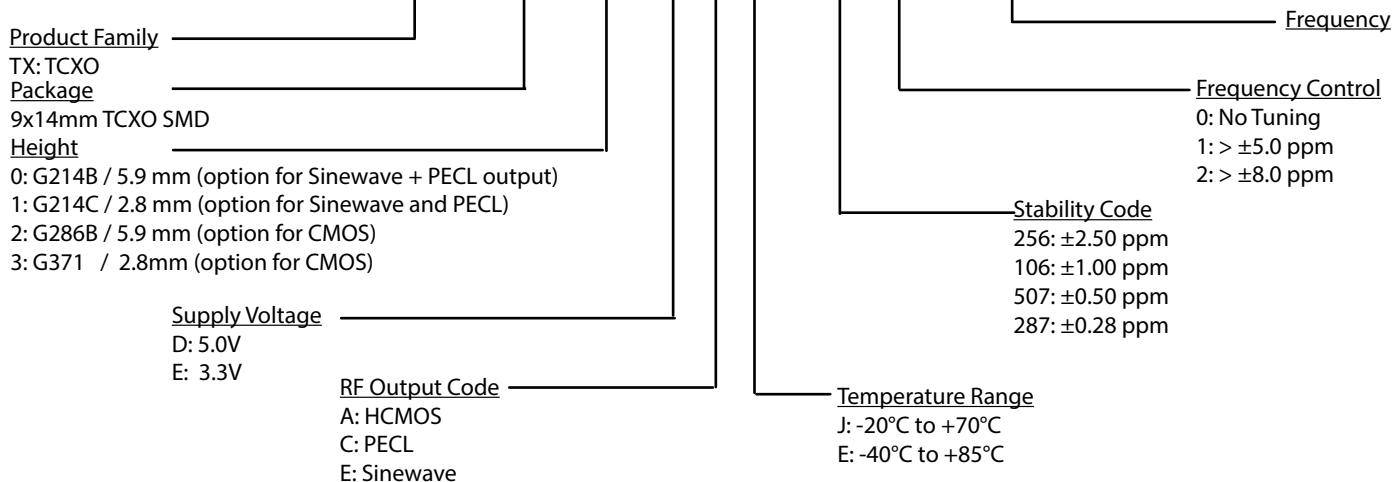

Notes:

1. Contact factory for improved stabilities or additional product options. Not all options and codes are available at all frequencies.
2. Phase noise degrades with increasing output frequency.
3. Contact factory for availability.

Unless other stated all values are valid at typical conditions for supply voltage, frequency control voltage, load, temperature (25°C).

Subject to technical modification.

Contact Information

USA:

100 Watts Street
Mt Holly Springs, PA 17065
Tel: 1.717.486.3411
Fax: 1.717.486.5920

Europe:

Landstrasse
74924 Neckarbischofsheim
Germany
Tel: +49 (0) 7268.801.0
Fax: +49 (0) 7268.801.281



Information contained in this publication regarding device applications and the like is provided only for your convenience and may be superseded by updates. It is your responsibility to ensure that your application meets with your specifications. MICROCHIP MAKES NO REPRESENTATION OR WARRANTIES OF ANY KIND WHETHER EXPRESS OR IMPLIED, WRITTEN OR ORAL, STATUTORY OR OTHERWISE, RELATED TO THE INFORMATION INCLUDING, BUT NOT LIMITED TO ITS CONDITION, QUALITY, PERFORMANCE, MERCHANTABILITY OR FITNESS FOR PURPOSE. Microchip disclaims all liability arising from this information and its use. Use of Microchip devices in life support and/or safety applications is entirely at the buyer's risk, and the buyer agrees to defend, indemnify and hold harmless Microchip from any and all damages, claims, suits, or expenses resulting from such use. No licenses are conveyed, implicitly, or otherwise, under any Microchip intellectual property rights unless otherwise stated.

Trademarks

The Microchip and Vectron names and logos are registered trademarks of Microchip Technology Incorporated in the U.S.A. and other countries.

Rev. May 2020