

DABiC-IV, 32-BIT SERIAL-INPUT, LATCHED SOURCE DRIVER

A6818xA

Dwg. FP-029-4

ABSOLUTE MAXIMUM RATINGS
at $T_A = 25^\circ\text{C}$

Logic Supply Voltage, V_{DD}	7.0 V
Driver Supply Voltage, V_{BB}	60 V
Continuous Output Current Range, I_{OUT}	-40 mA to +15 mA
Input Voltage Range, V_{IN}	-0.3 V to $V_{DD} + 0.3$ V
Package Power Dissipation, P_D	See Graph
Operating Temperature Range, T_A	
(Suffix 'E-')	-40°C to $+85^\circ\text{C}$
(Suffix 'K-')	-40°C to $+125^\circ\text{C}$
(Suffix 'S-')	-20°C to $+85^\circ\text{C}$
Storage Temperature Range, T_S	-55°C to $+125^\circ\text{C}$

Caution: These CMOS devices have input static protection (Class 2) but are still susceptible to damage if exposed to extremely high static electrical charges.

The A6818- devices combine a 32-bit CMOS shift register, accompanying data latches and control circuitry with bipolar sourcing outputs and pnp active pull downs. Designed primarily to drive vacuum-fluorescent displays, the 60 V and -40 mA output ratings also allow these devices to be used in many other peripheral power driver applications. The A6818- features an increased data input rate (compared with the older UCN/UCQ5818-F) and a controlled output slew rate.

The CMOS shift register and latches allow direct interfacing with microprocessor-based systems. With a 3.3 V or 5 V logic supply, typical serial-data input rates are up to 33 MHz.

A CMOS serial data output permits cascade connections in applications requiring additional drive lines. Similar devices are available as the A6809- and A6810- (10 bits), A6811- (12 bits), and A6812- (20 bits).

The A6818- output source drivers are npn Darlington's, capable of sourcing up to 40 mA. The controlled output slew rate reduces electromagnetic noise, which is an important consideration in systems that include telecommunications and/or microprocessors and to meet government emissions regulations. For inter-digit blanking, all output drivers can be disabled and all sink drivers turned on with a BLANKING input high. The pnp active pull-downs will sink at least 2.5 mA.

Three temperature ranges are available for optimum performance in commercial (suffix S-), industrial (suffix E-), or automotive (suffix K-) applications. Package styles are provided for through-hole DIP (suffix -A) or minimum-area surface-mount PLCC (suffix -EP). Copper lead frames, low logic-power dissipation, and low output-saturation voltages allow these devices to drive most multiplexed vacuum-fluorescent displays over the maximum operating temperature range.

FEATURES

- Controlled Output Slew Rate
- High-Speed Data Storage
- 60 V Minimum Output Breakdown
- High Data Input Rate
- PNP Active Pull-Downs
- Low Output-Saturation Voltages
- Low-Power CMOS Logic and Latches
- Improved Replacements for SN75518N, SN75518NF, UCN5818-, and UCQ5818-

Complete part number includes a suffix to identify operating temperature range (E-, K-, or S-) and package type (-A or -EP). Always order by complete part number, e.g., **A6818SEP**.

A6818 32-BIT SERIAL INPUT, LATCHED SOURCE DRIVER

TYPICAL INPUT CIRCUIT

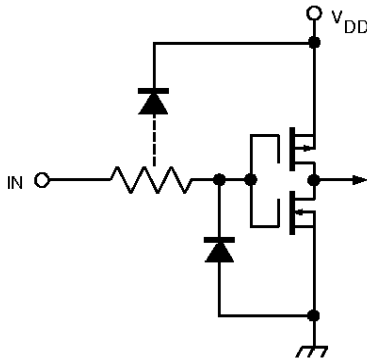

Dwg. EP-010-5

A6818xEP

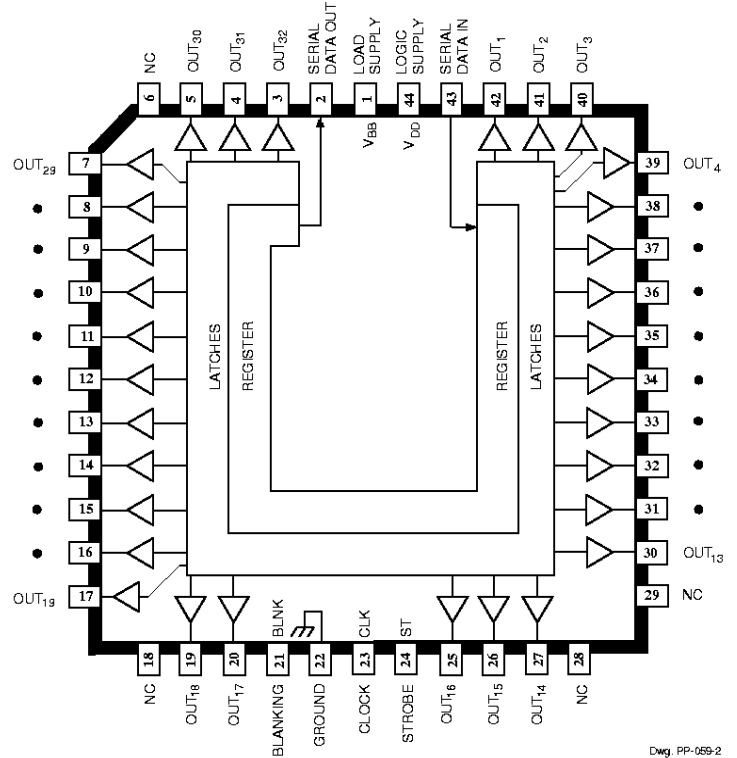

Dwg. PP-069-2

TYPICAL OUTPUT DRIVER

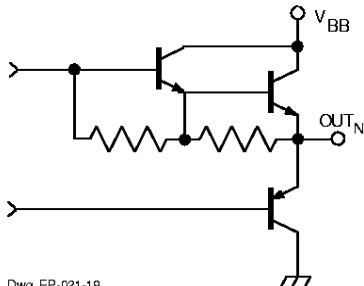

Dwg. EP-021-19

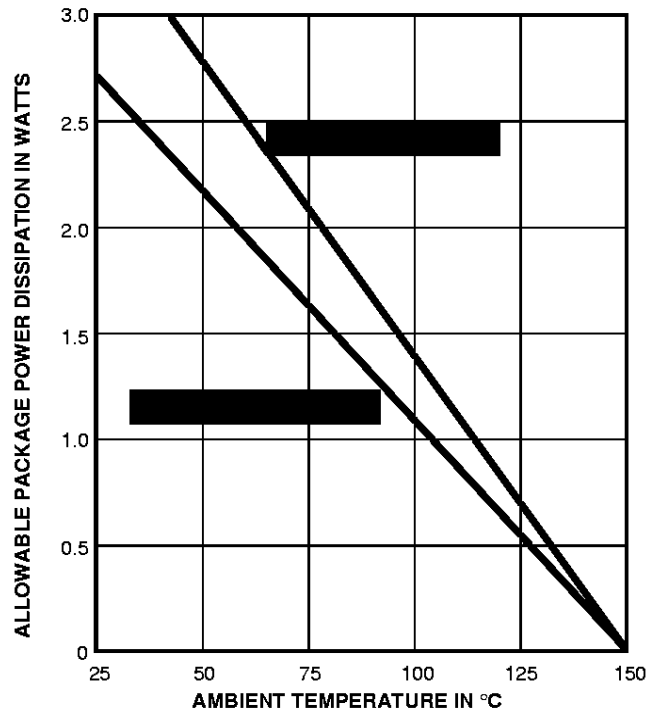

Dwg. GP-025A



6818

32-BIT SERIAL INPUT,
LATCHED SOURCE DRIVER

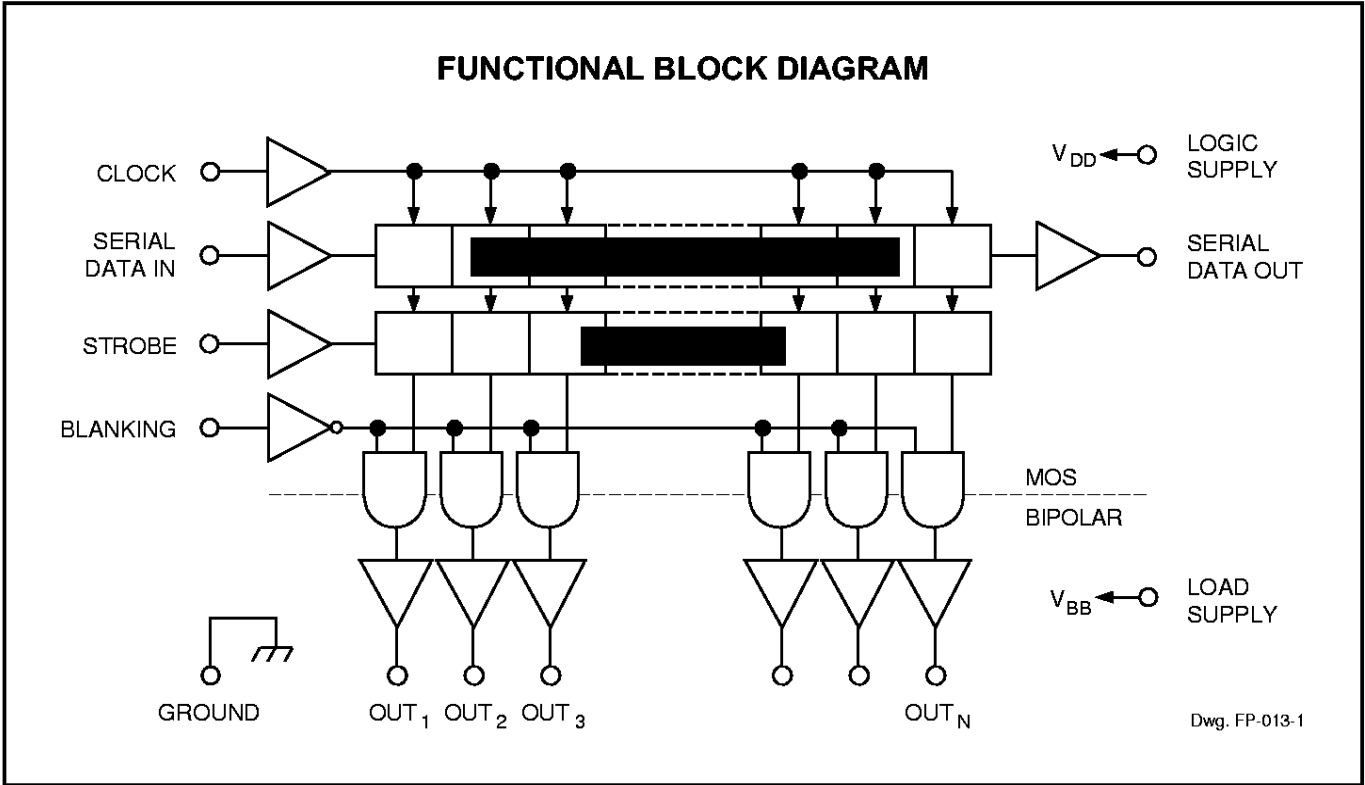

TRUTH TABLE

Serial Data Input	Clock Input	Shift Register Contents						Serial Data Output	Strobe Input	Latch Contents						Blanking	Output Contents					
		I ₁	I ₂	I ₃	...	I _{N-1}	I _N			I ₁	I ₂	I ₃	...	I _{N-1}	I _N		I ₁	I ₂	I ₃	...	I _{N-1}	I _N
H	⌋	H	R ₁	R ₂	...	R _{N-2}	R _{N-1}	R _{N-1}														
L	⌋	L	R ₁	R ₂	...	R _{N-2}	R _{N-1}	R _{N-1}														
X	⌋	R ₁	R ₂	R ₃	...	R _{N-1}	R _N	R _N														
		X	X	X	...	X	X	X	L	R ₁	R ₂	R ₃	...	R _{N-1}	R _N							
		P ₁	P ₂	P ₃	...	P _{N-1}	P _N	P _N	H	P ₁	P ₂	P ₃	...	P _{N-1}	P _N	L	P ₁	P ₂	P ₃	...	P _{N-1}	P _N
					...					X	X	X	...	X	X	H	L	L	L	...	L	L

L = Low Logic Level H = High Logic Level X = Irrelevant P = Present State R = Previous State

A6818

32-BIT SERIAL INPUT, LATCHED SOURCE DRIVER

ELECTRICAL CHARACTERISTICS at $T_A = +25^\circ\text{C}$ (A6818S-) or over operating temperature range (A6818E- and A6818K-), $V_{BB} = 60\text{ V}$ unless otherwise noted.

Characteristic	Symbol	Test Conditions	Limits @ $V_{DD} = 3.3\text{ V}$			Limits @ $V_{DD} = 5\text{ V}$			Units
			Min.	Typ.	Max.	Min.	Typ.	Max.	
Output Leakage Current	I_{OEX}	$V_{OUT} = 0\text{ V}$	—	<-0.1	-15	—	<-0.1	-15	μA
Output Voltage	$V_{OUT(1)}$	$I_{OUT} = -25\text{ mA}$	57.5	58.3	—	57.5	58.3	—	V
	$V_{OUT(0)}$	$I_{OUT} = 1\text{ mA}$	—	1.0	1.5	—	1.0	1.5	V
Output Pull-Down Current	$I_{OUT(0)}$	$V_{OUT} = 5\text{ V to }V_{BB}$	2.5	5.0	—	2.5	5.0	—	mA
Input Voltage	$V_{IN(1)}$		2.2	—	—	3.3	—	—	V
	$V_{IN(0)}$		—	—	1.1	—	—	1.7	V
Input Current	$I_{IN(1)}$	$V_{IN} = V_{DD}$	—	<0.01	1.0	—	<0.01	1.0	μA
	$I_{IN(0)}$	$V_{IN} = 0.8\text{ V}$	—	<-0.01	-1.0	—	<-0.01	-1.0	μA
Input Clamp Voltage	V_{IK}	$I_{IN} = -200\ \mu\text{A}$	—	-0.8	-1.5	—	-0.8	-1.5	V
Serial Data Output Voltage	$V_{OUT(1)}$	$I_{OUT} = -200\ \mu\text{A}$	2.8	3.05	—	4.5	4.75	—	V
	$V_{OUT(0)}$	$I_{OUT} = 200\ \mu\text{A}$	—	0.15	0.3	—	0.15	0.3	V
Maximum Clock Frequency	f_c		10	33	—	10	33	—	MHz
Logic Supply Current	$I_{DD(1)}$	All Outputs High	—	0.25	0.75	—	0.3	1.0	mA
	$I_{DD(0)}$	All Outputs Low	—	0.25	0.75	—	0.3	1.0	mA
Load Supply Current	$I_{BB(1)}$	All Outputs High, No Load	—	4.5	9.0	—	4.5	9.0	mA
	$I_{BB(0)}$	All Outputs Low	—	0.2	20	—	0.2	20	μA
Blanking-to-Output Delay	$t_{dis(BQ)}$	$C_L = 30\text{ pF}$, 50% to 50%	—	0.7	2.0	—	0.7	2.0	μs
	$t_{en(BQ)}$	$C_L = 30\text{ pF}$, 50% to 50%	—	1.8	3.0	—	1.8	3.0	μs
Strobe-to-Output Delay	$t_{p(STH-QL)}$	$R_L = 2.3\text{ k}\Omega$, $C_L \leq 30\text{ pF}$	—	0.7	2.0	—	0.7	2.0	μs
	$t_{p(STH-QH)}$	$R_L = 2.3\text{ k}\Omega$, $C_L \leq 30\text{ pF}$	—	1.8	3.0	—	1.8	3.0	μs
Output Fall Time	t_f	$R_L = 2.3\text{ k}\Omega$, $C_L \leq 30\text{ pF}$	2.4	—	12	2.4	—	12	μs
Output Rise Time	t_r	$R_L = 2.3\text{ k}\Omega$, $C_L \leq 30\text{ pF}$	2.4	—	12	2.4	—	12	μs
Output Slew Rate	dV/dt	$R_L = 2.3\text{ k}\Omega$, $C_L \leq 30\text{ pF}$	4.0	—	20	4.0	—	20	V/ μs
Clock-to-Serial Data Out Delay	$t_{p(CH-SQX)}$	$I_{OUT} = \pm 200\ \mu\text{A}$	—	50	—	—	50	—	ns

Negative current is defined as coming out of (sourcing) the specified device terminal.

Typical data is for design information only and is at $T_A = +25^\circ\text{C}$.



TIMING REQUIREMENTS and SPECIFICATIONS

(Logic Levels are V_{DD} and Ground)

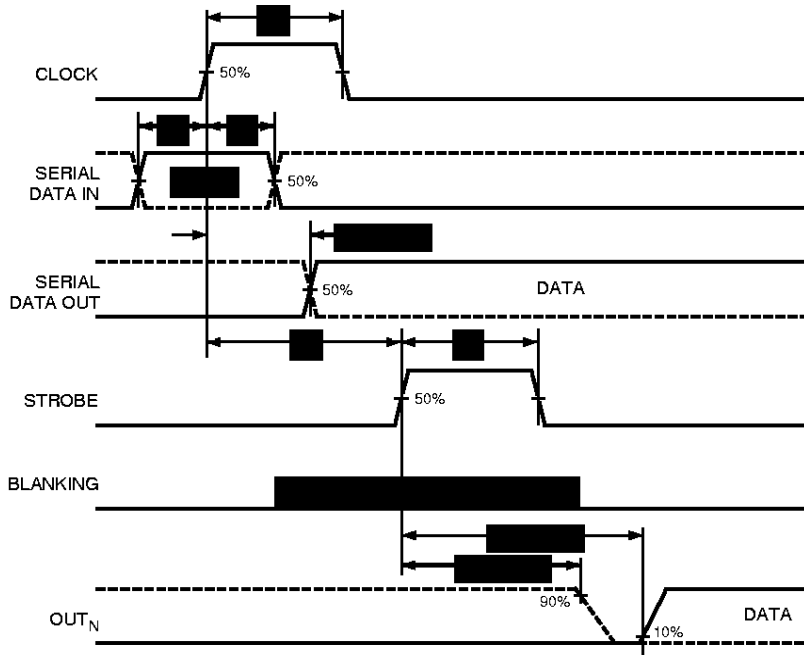

Dwg. WP-029

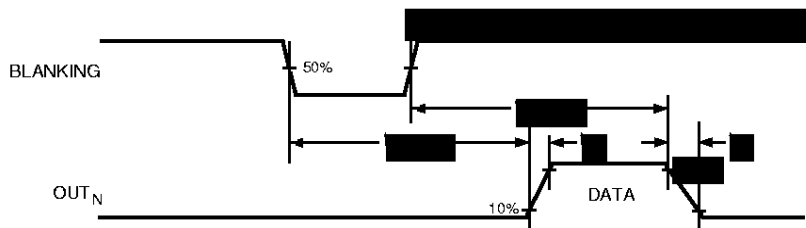

Dwg. WP-030

- A. Data Active Time Before Clock Pulse
(Data Set-Up Time), $t_{su(D)}$ **25 ns**
- B. Data Active Time After Clock Pulse
(Data Hold Time), $t_{h(D)}$ **25 ns**
- C. Clock Pulse Width, $t_{w(CH)}$ **50 ns**
- D. Time Between Clock Activation and Strobe, $t_{su(C)}$ **100 ns**
- E. Strobe Pulse Width, $t_{w(STH)}$ **50 ns**

NOTE – Timing is representative of a 10 MHz clock. Significantly higher speeds are attainable.

Serial Data present at the input is transferred to the shift register on the logic “0” to logic “1” transition of the CLOCK input pulse. On succeeding CLOCK pulses, the registers shift data information towards the SERIAL DATA OUTPUT. The SERIAL DATA must appear at the input prior to the rising edge of the CLOCK input waveform.

Information present at any register is transferred to the respective latch when the STROBE is high (serial-to-parallel conversion). The latches will continue to accept new data as long as the STROBE is held high. Applications where the latches are bypassed (STROBE tied high) will require that the BLANKING input be high during serial data entry.

When the BLANKING input is high, the output source drivers are disabled (OFF); the pnp active pull-down sink drivers are ON. The information stored in the latches is not affected by the BLANKING input. With the BLANKING input low, the outputs are controlled by the state of their respective latches.

A6818
32-BIT SERIAL INPUT,
LATCHED SOURCE DRIVER

A6818EA, A6811KA, & A6811SA

Dimensions in Inches
 (controlling dimensions)

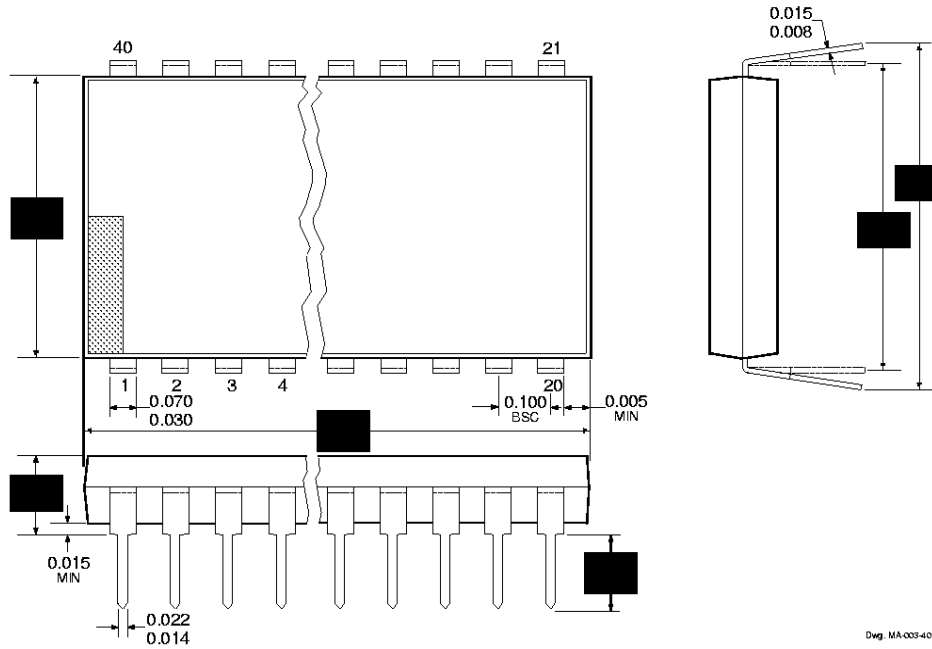

Dwg. MA-003-40.in

Dimensions in Millimeters
 (for reference only)

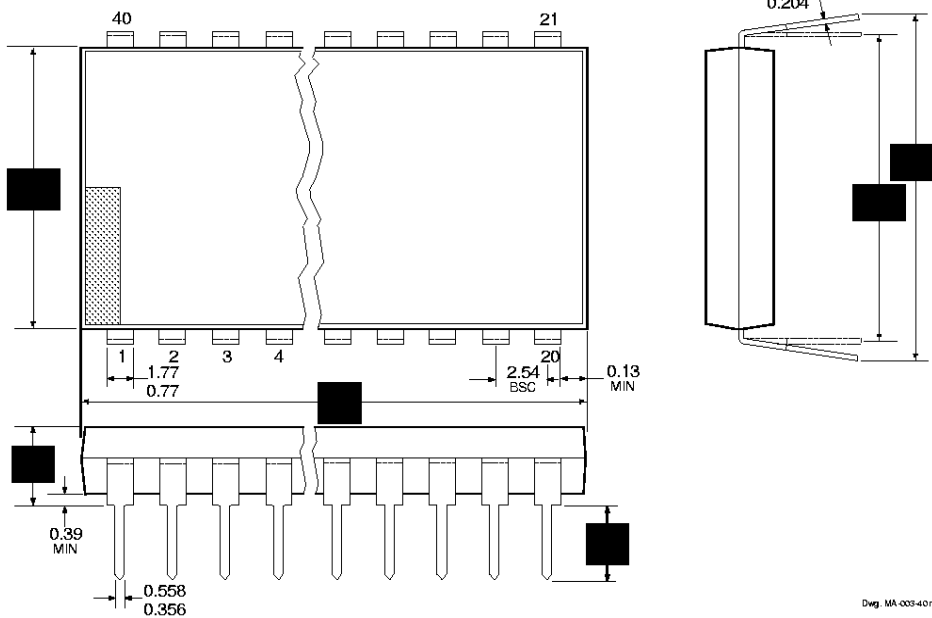

Dwg. MA-003-40.mm

- NOTES: 1. Exact body and lead configuration at vendor's option within limits shown.
 2. Lead spacing tolerance is non-cumulative.
 3. Lead thickness is measured at seating plane or below.



115 Northeast Cutoff, Box 15036
 Worcester, Massachusetts 01615-0036 (508) 853-5000

6818
32-BIT SERIAL INPUT,
LATCHED SOURCE DRIVER

A6818EEP, A6818KEP, & A6818SEP

Dimensions in Inches
 (controlling dimensions)

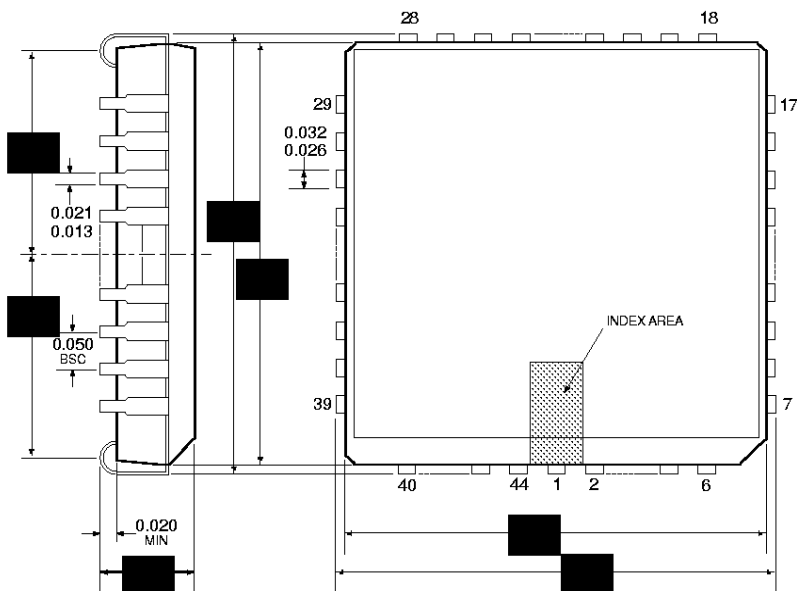

Dwg. MA-005-44A.in

Dimensions in Millimeters
 (for reference only)

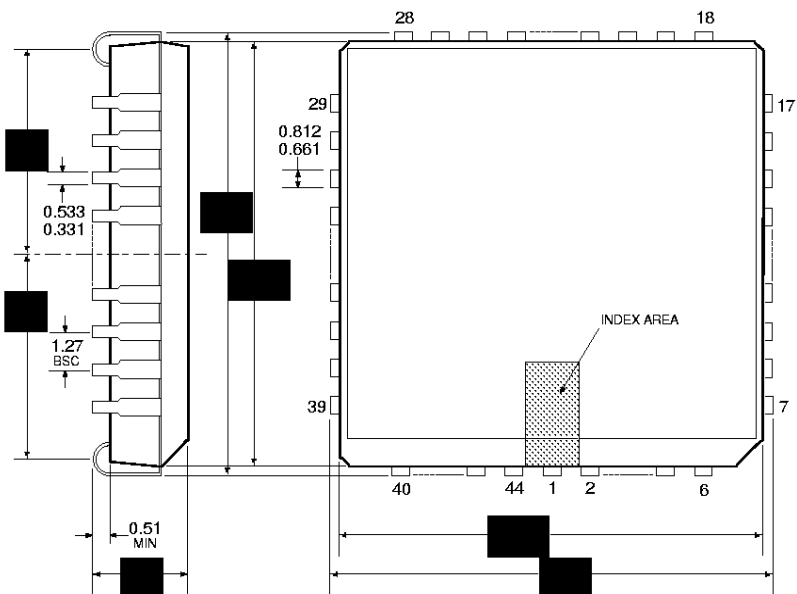

Dwg. MA-005-44A.mm

- NOTES: 1. Exact body and lead configuration at vendor's option within limits shown.
 2. Lead spacing tolerance is non-cumulative.

6818
32-BIT SERIAL-INPUT,
LATCHED SOURCE DRIVER

BiMOS II (Series 5800) & DABiC IV (Series 6800)
INTELLIGENT POWER INTERFACE DRIVERS
SELECTION GUIDE

Function	Output Ratings *		Part Number †
SERIAL-INPUT LATCHED DRIVERS			
8-Bit (saturated drivers)	-120 mA	50 V‡	5895
8-Bit	350 mA	50 V	5821
8-Bit	350 mA	80 V	5822
8-Bit	350 mA	50 V‡	5841
8-Bit	350 mA	80 V‡	5842
8-Bit (constant-current LED driver)	75 mA	17 V	6275
9-Bit	1.6 A	50 V	5829
10-Bit (active pull-downs)	-25 mA	60 V	5810-F and 6809/10
12-Bit (active pull-downs)	-25 mA	60 V	5811 and 6811
16-Bit (constant-current LED driver)	75 mA	17 V	6276
20-Bit (active pull-downs)	-25 mA	60 V	5812-F and 6812
32-Bit (active pull-downs)	-25 mA	60 V	5818-F and 6818
32-Bit	100 mA	30 V	5833
32-Bit (saturated drivers)	100 mA	40 V	5832
PARALLEL-INPUT LATCHED DRIVERS			
4-Bit	350 mA	50 V‡	5800
8-Bit	-25 mA	60 V	5815
8-Bit	350 mA	50 V‡	5801
SPECIAL-PURPOSE FUNCTIONS			
Unipolar Stepper Motor Translator/Driver	1.25 A	50 V‡	5804
Addressable 28-Line Decoder/Driver	450 mA	30 V	6817

* Current is maximum specified test condition, voltage is maximum rating. See specification for sustaining voltage limits. Negative current is defined as coming out of (sourcing) the output.

† Complete part number includes additional characters to indicate operating temperature range and package style.

‡ Internal transient-suppression diodes included for inductive-load protection.

Allegro MicroSystems, Inc. reserves the right to make, from time to time, such departures from the detail specifications as may be required to permit improvements in the design of its products.

The information included herein is believed to be accurate and reliable. However, Allegro MicroSystems, Inc. assumes no responsibility for its use; nor for any infringements of patents or other rights of third parties which may result from its use.

