

TMS4161 65,536-BIT MULTI-PORT VIDEO RAM

JULY 1983 - REVISED NOVEMBER 1985

- **Dual Accessibility — One Port Sequential Access, One Port Random Access**
- **Four Cascaded 64-Bit Serial Shift Registers for Sequential Access Applications**
- **Designed for Both Video and Non-Video Applications**
- **Fast Serial Port . . . Can Be Configured for Video Data Rates in Excess of 150 MHz**
- **TR/QE as Output Enable Allows Direct Connection of D, Q and Address Lines to Simplify System Design**
- **Random Access Port Looks Exactly Like a TMS4164**
- **Separate Serial In and Serial Out to Allow Simultaneous Shift In and Out**
- **65,536 × 1 Organization**
- **Supported by TI's TMS34061 Video System Controller (VSC)**
- **Maximum Access Time from RAS Less Than 150 ns**
- **Minimum Cycle Time (Read or Write) Less Than 240 ns**
- **Long Refresh Period . . . 4 ms**
- **Low Refresh Overhead Time . . . As Low As 1.7% of Total Refresh Period**
- **All Inputs, Outputs, Clocks Fully TTL Compatible**
- **3-State Unlatched Outputs for Both Random and Serial Access**
- **Common I/O Capability with "Early Write" Feature**
- **Page-Mode Operation for Faster Access**
- **Low Power Dissipation (TMS4161-15)**
— Operating . . . 250 mW (Typical)
— Standby . . . 80 mW (Typical)
- **New SMOS (Scaled-MOS) N-Channel Technology**
- **SOE Simplifies Multiplexing of Serial Data Streams**
- **Available with MIL-STD-883B Processing and L(0°C to 70°C), E(-40°C to 85°C), or S(-55°C to 100°C) Temperature Ranges**

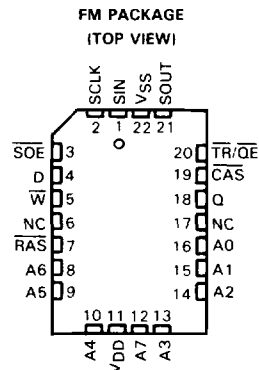
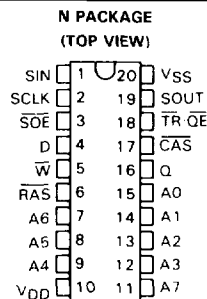

PIN NOMENCLATURE			
A0-A7	Address Inputs	SIN	Serial Data In
CAS	Column-Address Strobe	SOE	Serial Output Enable
D	Random-Access Data In	SOUT	Serial Data Out
NC	No Connection	TR/QE	Register Transfer/ Q Output Enable
Q	Random-Access Data Out	VDD	5-V Supply
RAS	Row-Address Strobe	VSS	Ground
SCLK	Serial Data Clock	W	Write Enable

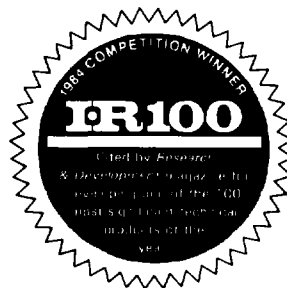

PRODUCTION DATA documents contain information current as of publication date. Products conform to specifications per the terms of Texas Instruments standard warranty. Production processing does not necessarily include testing of all parameters.

**TEXAS
INSTRUMENTS**

POST OFFICE BOX 1443 • HOUSTON, TEXAS 77001

Copyright © 1985, Texas Instruments Incorporated

TMS4161

65,536-BIT MULTIPORT VIDEO RAM

description

The TMS4161 is a high-speed, dual-access 65,536-bit dynamic random-access memory. The random-access port makes the memory look like it is organized as 65,536 words of one bit each like the TMS4164. The sequential access port is interfaced to an internal 256-bit dynamic shift register organized as four cascaded 64-bit shift registers which makes the memory look like it is organized as up to 256 words of up to 256 bits each which are accessed serially. One, two, three, or four 64-bit shift registers can be sequentially read out after a transfer cycle depending on a two-bit code applied to the two most significant column address inputs. The TMS4161 employs state-of-the-art SMOS (Scaled-MOS) N-channel double-level polysilicon gate technology for very high performance combined with low cost and improved reliability.

The TMS4161 features full asynchronous dual access capability except when transferring data between the shift register and the memory array.

Refresh period is extended to 4 milliseconds, and during this period each of the 256 rows must be strobed with $\overline{\text{RAS}}$ in order to retain data. $\overline{\text{CAS}}$ can remain high during the refresh sequence to conserve power. Note that the transfer of a row of data from the memory array to the shift register also refreshes that row.

All inputs and outputs, including clocks, are compatible with Series 74 TTL. All address lines and data in are latched on chip to simplify system design. Data out is unlatched to allow greater system flexibility.

The TMS4161 is offered in 20-pin plastic dual-in-line and 22-pin plastic chip carrier packages. It is guaranteed for operation from 0°C to 70°C. The dual-in-line package is designed for insertion in mounting-hole rows on 7,62-mm (300-mil) centers.

random access address space to sequential address space mapping

The TMS4161 is designed with each row divided into four, 64-column sections (see functional block diagram). The first column section to be shifted out is selected by the two most significant column address bits. If the two bits represent binary 00, then one to four registers can be shifted out in order. If the two bits represent binary 01, then only 1 to 3 (the most significant) registers can be shifted out in order. If the two bits represent 10, then one to two of the most significant registers can be shifted out in order. Finally, if the two bits represent 11 only the most significant register can be shifted out. All registers are shifted out with the least significant bit (bit 0) first and the most significant bit (bit 63) last. Note that if the two column address bits equal 00 during the last register transfer cycle ($\overline{\text{TR}}/\overline{\text{QE}}$ at logic level "0" as $\overline{\text{RAS}}$ falls) a total of 256 bits can be sequentially read out.

functional block diagram

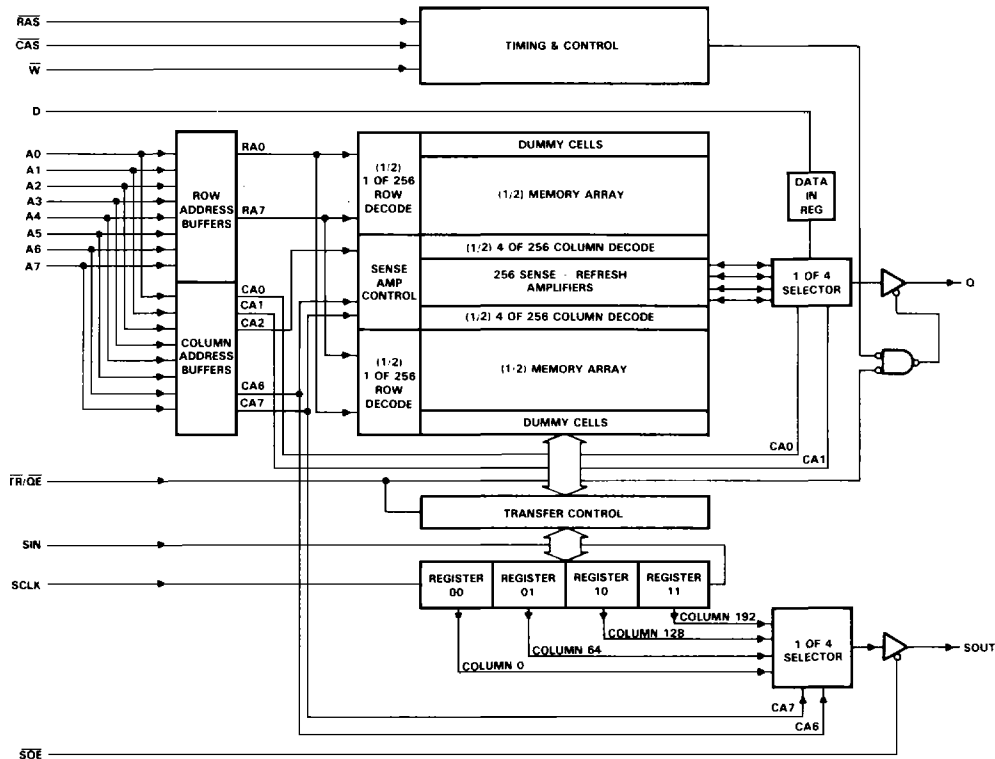

4
Dynamic RAMs

random-access operation

$\overline{TR}/\overline{QE}$

The $\overline{TR}/\overline{QE}$ pin has two functions. First, it selects either register transfer or random-access operation as \overline{RAS} falls, and second, if this is a random-access operation, it functions as an output enable after \overline{CAS} falls.

To use the TMS4161 in the random-access mode, $\overline{TR}/\overline{QE}$ must be high as \overline{RAS} falls. Holding $\overline{TR}/\overline{QE}$ high as \overline{RAS} falls keeps the 256 elements of the shift registers disconnected from the corresponding 256 bit lines of the memory array. If data is to be shifted, the shift registers must be disconnected from the bit lines. Holding $\overline{TR}/\overline{QE}$ low as \overline{RAS} falls enables the 256 switches that connect the shift registers to the bit lines and indicates that a transfer will occur between the shift registers and one of the memory rows.

During random-access operation, once \overline{CAS} has been pulled low, $\overline{TR}/\overline{QE}$ controls when the data will appear at the Q output (if this is a read cycle). Whenever $\overline{TR}/\overline{QE}$ is held high during random-access operation, the Q output will be in the high-impedance state. This feature removes the possibility of an overlap between data on the address lines and data appearing on the Q output making it possible to connect the address lines to the Q and D lines (Use of this organization prohibits the use of the early write cycle.).

address (A0 through A7)

Sixteen address bits are required to decode 1 of 65,536 storage cell locations. Eight row-address bits are set up on pins A0 through A7 and latched onto the chip by the row-address strobe ($\overline{\text{RAS}}$). Then the eight column-address bits are set up on pins A0 through A7 and latched onto the chip by the column-address strobe ($\overline{\text{CAS}}$). All addresses must be stable on or before the falling edges of $\overline{\text{RAS}}$ and $\overline{\text{CAS}}$. $\overline{\text{RAS}}$ is similar to a chip enable in that it activates the sense amplifiers as well as the row decoder. $\overline{\text{CAS}}$ is used as a chip select activating the column decoder and the input and output buffers.

write enable ($\overline{\text{W}}$)

The read or write mode is selected through the write-enable ($\overline{\text{W}}$) input. A logic high on the $\overline{\text{W}}$ input selects the read mode and a logic low selects the write mode. The write-enable terminal can be driven from standard TTL circuits without a pull-up resistor. The data input is disabled when the read mode is selected. When $\overline{\text{W}}$ goes low prior to $\overline{\text{CAS}}$, data out will remain in the high-impedance state for the entire cycle permitting common I/O operation.

data in (D)

Data is written during a write or read-modify-write cycle. The falling edge of $\overline{\text{CAS}}$ or $\overline{\text{W}}$ strobes data into the on-chip data latch. This latch can be driven from standard TTL circuits without a pull-up resistor. In an early write cycle, $\overline{\text{W}}$ is brought low prior to $\overline{\text{CAS}}$ and the data is strobed in by $\overline{\text{CAS}}$ with setup and hold times referenced to this signal. In a delayed write or read-modify-write cycle, $\overline{\text{CAS}}$ will already be low, thus the data will be strobed in by $\overline{\text{W}}$ with setup and hold times referenced to this signal.

data out (Q)

The three-state output buffer provides direct TTL compatibility (no pull-up resistor required) with a fan out of two Series 74 TTL loads. Data out is the same polarity as data in. The output is in the high-impedance (floating) state as long as $\overline{\text{CAS}}$ or $\overline{\text{TR}/\overline{\text{QE}}}$ is held high. Data will not appear on the output until after both $\overline{\text{CAS}}$ and $\overline{\text{TR}/\overline{\text{QE}}}$ have been brought low. In a read cycle, the guaranteed maximum output enable access time is valid only if t_{CQE} is greater than $t_{\text{CQE MAX}}$, and t_{RLCL} is greater than $t_{\text{RLCL MAX}}$. Likewise, $t_{\text{a(C) MAX}}$ is valid only if t_{RLCL} is greater than $t_{\text{RLCL MAX}}$. Once the output is valid, it will remain valid while $\overline{\text{CAS}}$ and $\overline{\text{TR}/\overline{\text{QE}}}$ are both low; $\overline{\text{CAS}}$ or $\overline{\text{TR}/\overline{\text{QE}}}$ going high will return the output to a high-impedance state. In an early write cycle, the output is always in a high-impedance state. In a delayed write or read-modify-write cycle, the output will follow the sequence for the read cycle. In a register transfer cycle, the output will always be in a high-impedance state.

refresh

A refresh operation must be performed at least every four milliseconds to retain data. Since the output buffer is in high-impedance state unless $\overline{\text{CAS}}$ is applied, the $\overline{\text{RAS}}$ -only refresh sequence avoids any output during refresh. Strobing each of the 256 row addresses (A0 through A7) with $\overline{\text{RAS}}$ causes all bits in each row to be refreshed. $\overline{\text{CAS}}$ can remain high (inactive) for this refresh sequence to conserve power.

page mode

Page-mode operation allows effectively faster memory access by keeping the same row address and strobing successive column addresses onto the chip. Thus, the time required to setup and strobe sequential row addresses for the same page is eliminated. To extend beyond the 256 column locations on a single RAM, the row address and $\overline{\text{RAS}}$ are applied to multiple 64K RAMs. $\overline{\text{CAS}}$ is then decoded to select the proper RAM.

power up

After power up, the power supply must remain at its steady-state value for 1 ms. In addition, $\overline{\text{RAS}}$ must remain high for 100 μs immediately prior to initialization. Initialization consists of performing eight $\overline{\text{RAS}}$ cycles before proper device operation is achieved.

sequential-access operation

$\overline{TR}/\overline{OE}$

Memory transfer operations involving parallel use of the shift register are first indicated by bringing $\overline{TR}/\overline{OE}$ low before \overline{RAS} falls low. This enables the switches connecting the 256 elements of the shift register to the 256 bit lines of the memory array. The \overline{W} line determines whether the data will be transferred from or to the shift registers.

write enable (\overline{W})

In the sequential access mode, \overline{W} determines whether a transfer will occur from the shift registers to the memory array, or from the memory array to the shift registers. To transfer from the shift registers to the memory array, \overline{W} is held low as \overline{RAS} falls, and, to transfer from the memory array to the shift registers, \overline{W} is held high as \overline{RAS} falls. Thus, reads and writes are always with respect to the memory array. The write setup and hold times are referenced to the falling edge of \overline{RAS} for this mode of operation.

row address (A0 through A7)

Eight address bits are required to select one of the 256 possible rows involved in the transfer of data to or from the shift registers. A0-A7, \overline{W} , and $\overline{TR}/\overline{OE}$ are latched on the falling edge of \overline{RAS} .

register column address (A7, A6)

To select one of the four shift registers (transfer from memory to register only), the appropriate 2-bit column address (A7, A6) must be valid when \overline{CAS} falls. However, the \overline{CAS} and register address signals need not be supplied every transfer cycle, only when it is desired to change or select a new register.

SCLK

Data is shifted in and out on the rising edge of SCLK. This makes it possible to view the shift registers as though it were made of 256 rising edge D flip-flops connected D to Q. The TMS4161 is designed to work with a wide range duty cycle clock to simplify system design. Note that data will appear at the SOUT pin not only on the rising edge of SCLK but also after an access time of $t_a(RSO)$ from \overline{RAS} high during a parallel load of the shift registers.

SIN and SOUT

Data is shifted in through the SIN pin and is shifted out through the SOUT pin. The TMS4161 is designed such that it requires 3 ns hold time on SIN as SCLK rises. SOUT is guaranteed not to change for at least 8 ns after SCLK rises. These features make it possible to easily connect TMS4161s together, to allow SOUT to be connected to SIN, and to give external circuitry a full SCLK cycle time to allow manipulation of the serial data. When loading data into the shift register from the serial input in preparation for a shift register to memory transfer operation, the serial clock must be clocked an even number of times. To guarantee proper serial clock sequence after power up, a transfer cycle must be initiated before a serial data stream is applied at SIN.

\overline{SOE}

The serial output enable pin controls the impedance of the serial output, allowing multiplexing of more than one bank of TMS4161 memories into the same external video circuitry. When \overline{SOE} is at a logic low level, SOUT will be enabled and the proper data read out. When \overline{SOE} is at a logic high level, SOUT will be disabled and be in the high-impedance state.

TMS4161

65,536-BIT MULTIPOINT VIDEO RAM

refresh

The shift registers are also dynamic storage elements. The data held in the registers will be lost unless SCLK goes high to shift the data one bit position, a transfer write operation is invoked, or the data is reloaded from the memory array. See specifications for maximum register data retention times. Important: If the shift register has remained idle for a time period which exceeds the maximum SCLK high or SCLK low time, the dynamic clock circuits will also lose charge. Under these conditions, the shift register clocks must be re-enabled by performing any transfer cycle before data can be shifted into or out of the shift register.

absolute maximum ratings over operating free-air temperature range (unless otherwise noted)†

Voltage range on any pin except V _{DD} and data out (see Note 1)	-1.5 V to 10 V
Voltage range on V _{DD} supply and data out with respect to V _{SS}	-1 V to 6 V
Short circuit output current	50 mA
Power dissipation	1 W
Operating free-air temperature	0°C to 70°C
Storage temperature range	-65°C to 150°C

†Stresses beyond those listed under "Absolute Maximum Ratings" may cause permanent damage to the device. This is a stress rating only and functional operation of the device at these or any other conditions beyond those indicated in the "Recommended Operating Conditions" section of this specification is not implied. Exposure to absolute-maximum-rated conditions for extended periods may affect device reliability.

NOTE 1: All voltage values in this data sheet are with respect to V_{SS}.

recommended operating conditions

		MIN	NOM	MAX	UNIT
V _{DD}	Supply voltage	4.5	5	5.5	V
V _{SS}	Supply voltage		0		V
V _{IH}	High-level input voltage	2.4		V _{DD} +0.3	V
V _{IL}	Low-level input voltage (see Notes 2 and 3)	-0.6		0.8	V
T _A	Operating free-air temperature	0		70	°C

- NOTES: 2. The algebraic convention, where the more negative (less positive) limit is designated as minimum, is used in this data sheet for logic voltage levels only.
3. Due to input protection circuitry, the applied voltage may begin to clamp at -0.6 V; test conditions must comprehend this occurrence.
4. See application report entitled "TMS4164A and TMS4416 Input Protection Diode" on page 9-5.

electrical characteristics over full range of recommended operating conditions (unless otherwise noted)

PARAMETER	TEST CONDITIONS	TMS4161-15		TMS4161-20		UNIT		
		MIN	TYP [†] MAX	MIN	TYP [†] MAX			
V _{OH}	High-level output voltage (Q, SOUT)	I _{OH} = -5 mA		2.4		V		
V _{OL}	Low-level output voltage (Q, SOUT)	I _{OL} = 4.2 mA		0.4		V		
i _i	Input current (leakage)	V _i = 0 V to 5.8 V, V _{DD} = 5 V, All other pins = 0 V		± 10		μA		
I _O	Output current (leakage) (Q, SOUT)	V _O = 0.4 V to 5.5 V, V _{DD} = 5 V		± 10		μA		
I _{DD1}	Average operating current during read or write cycle	t _{c(rd)} = minimum cycle time, TR/QE low after RAS falls, [‡] SCLK and SIN low, SOE high, No load on Q and SOUT		50	70	50	70	mA
I _{DD2} [§]	Standby current	After 1 RAS cycle, RAS and CAS high, SCLK and SIN low, SOE high, No load on Q and SOUT		16	20	16	20	mA
I _{DD3}	Average refresh current	t _{c(rd)} = minimum cycle time, CAS high, RAS cycling, SCLK and SIN low, SOE high, TR/QE high, No load on Q and SOUT		42	55	37	50	mA
I _{DD4}	Average page-mode current	t _{c(P)} = minimum cycle time, RAS low, CAS cycling, TR/QE low after RAS falls, SCLK and SIN low, SOE high, No load on Q and SOUT		45	55	40	50	mA
I _{DD5}	Average shift register current (includes I _{DD2})	RAS and CAS high, No load on Q and SOUT, t _{c(SCLK)} = t _{c(SCLK)} min		30	40	30	40	mA
I _{DD6}	Worst case average DRAM and shift register current	t _{c(rd)} = minimum cycle time, t _{c(SCLK)} = minimum cycle time, TR/QE low after RAS falls, No load on Q and SOUT		85	95	80	90	mA

NOTE 5: Additional information on I_{DD1} - I_{DD6} on page 4-40.

[†] All typical values are at T_A = 25°C and nominal supply voltages.

[‡] See appropriate timing diagram.

[§] V_{IL} > -0.6 V.

4

Dynamic RAMs

TMS4161
65,536-BIT MULTIPOINT VIDEO RAM

capacitance over recommended supply voltage and operating free-air temperature range, $f = 1 \text{ MHz}$

PARAMETER		TYP [†]	MAX	UNIT
$C_{i(A)}$	Input capacitance, address inputs	4	5	pF
$C_{i(D)}$	Input capacitance, data input	4	5	
$C_{i(RC)}$	Input capacitance, strobe inputs	8	10	
$C_{i(W)}$	Input capacitance, write enable input	8	10	
$C_{i(CK)}$	Input capacitance, serial clock	8	10	
$C_{i(SI)}$	Input capacitance, serial in	4	5	
$C_{i(SOE)}$	Input capacitance, serial output enable	4	5	
$C_{i(TR)}$	Input capacitance, register transfer input	4	5	
$C_{o(Q)}$	Output capacitance, random-access data	5	7	
$C_{o(SOUT)}$	Output capacitance, serial out	5	7	

[†] All typical values are at $T_A = 25^\circ\text{C}$ and nominal supply voltages.

4

Dynamic RAMs

switching characteristics over recommended supply voltage range and operating free-air temperature range (see Figure 1)

PARAMETER	TEST CONDITIONS [†]	ALT. SYMBOL	TMS4161-15		TMS4161-20		UNIT
			MIN	MAX	MIN	MAX	
$t_a(C)$	Access time from $\overline{\text{CAS}}$	$C_L = 100 \text{ pF}$		100		135	ns
$t_a(QE)$	Access time of Q from $\overline{\text{TR}}/\overline{\text{OE}}$ low	$C_L = 100 \text{ pF}$		40		50	
$t_a(R)$	Access time from $\overline{\text{RAS}}$	$t_{RLCL} = \text{MAX},$ $C_L = 100 \text{ pF}$		150		200	
$t_a(RSO)$	SOUT access time from $\overline{\text{RAS}}$ high	$C_L = 30 \text{ pF}$		65		85	
$t_a(SOE)$	Access time from $\overline{\text{SOE}}$ low to SOUT	$C_L = 30 \text{ pF}$		20		25	
$t_a(SO)$	Access time from SCLK	$C_L = 30 \text{ pF}$		45		50	
$t_{\text{dis}}(\text{CH})^\ddagger$	Q output disable time from $\overline{\text{CAS}}$ high	$C_L = 100 \text{ pF}$		40		40	
$t_{\text{dis}}(\text{QE})^\ddagger$	Q output disable time from $\overline{\text{TR}}/\overline{\text{OE}}$ high	$C_L = 100 \text{ pF}$		30		40	
$t_{\text{dis}}(\text{SOE})^\ddagger$	Serial output disable time from $\overline{\text{SOE}}$ high	$C_L = 30 \text{ pF}$		20		25	

[†] Figure 1 shows the load circuit.

[‡] The maximum values for $t_{\text{dis}}(\text{CH})$, $t_{\text{dis}}(\text{QE})$, and $t_{\text{dis}}(\text{SOE})$ define the time at which the output achieves the open circuit condition and are not referenced to V_{OH} or V_{OL} .

timing requirements over recommended supply voltage range and operating free-air temperature range

	ALT. SYMBOL	TMS4161-15		TMS4161-20		UNIT
		MIN	MAX	MIN	MAX	
$t_{c(P)}$ Page-mode cycle time	t_{PC}	160		225		ns
$t_{c(rd)}$ Read cycle time [†]	t_{RC}	240		315		ns
$t_{c(W)}$ Write cycle time	t_{WC}	240		315		ns
$t_{c(TW)}$ Transfer write cycle time [‡]		240		315		ns
$t_{c(Trd)}$ Transfer read cycle time		240		315		ns
$t_{c(rdW)}$ Read-write/read-modify-write cycle time	t_{RWC}	265		330		ns
$t_{c(SCLK)}$ Serial-clock cycle time	t_{SCC}	45	50,000	50	50,000	ns
$t_w(CH)$ Pulse duration, \overline{CAS} high (precharge time [§])	t_{CP}	50		80		ns
$t_w(CL)$ Pulse duration, \overline{CAS} low [¶]	t_{CAS}	100	10,000	135	10,000	ns
$t_w(RH)$ Pulse duration, \overline{RAS} high (precharge time)	t_{RP}	80		105		ns
$t_w(RL)$ Pulse duration, \overline{RAS} low [#]	t_{RAS}	150	10,000	200	10,000	ns
$t_w(W)$ Write pulse duration	t_{WP}	45		45		ns
$t_w(CKL)$ Pulse duration, SCLK low		10		10		ns
$t_w(CKH)$ Pulse duration, SCLK high		12		12		ns
$t_w(QE)$ $\overline{TR}/\overline{OE}$ pulse duration low time (read cycle)		40		40		ns
t_t Transition times (rise and fall) \overline{RAS} , \overline{CAS} , and SCLK	t_T	3	50	3	50	ns
$t_{su(CA)}$ Column-address setup time	t_{ASC}	0		0		ns
$t_{su(RA)}$ Row-address setup time	t_{ASR}	0		0		ns
$t_{su(RW)}$ \overline{W} setup time before \overline{RAS} low with $\overline{TR}/\overline{OE}$ low		0		0		ns
$t_{su(D)}$ Data setup time	t_{DS}	0		0		ns
$t_{su(rd)}$ Read-command setup time	t_{RCS}	0		0		ns
$t_{su(WCL)}$ Early write-command setup time before \overline{CAS} low	t_{WCS}	-5		-5		ns
$t_{su(WCH)}$ Write-command setup time before \overline{CAS} high	t_{CWL}	40		60		ns
$t_{su(WRH)}$ Write-command setup time before \overline{RAS} high	t_{RWL}	40		60		ns
$t_{su(TR)}$ $\overline{TR}/\overline{OE}$ setup time before \overline{RAS} low		0		0		ns
$t_{su(SI)}$ Serial-data setup time before SCLK high		6		6		ns
$t_h(SI)$ Serial-data-in hold time after SCLK high		3		3		ns
$t_h(CLCA)$ Column-address hold time after \overline{CAS} low	t_{CAH}	45		55		ns
$t_h(RA)$ Row-address hold time	t_{RAH}	20		25		ns
$t_h(RW)$ \overline{W} hold time after \overline{RAS} low with $\overline{TR}/\overline{OE}$ low		20		20		ns
$t_h(RLCA)$ Column-address hold time after \overline{RAS} low	t_{AR}	95		120		ns
$t_h(CLD)$ Data hold time after \overline{CAS} low	t_{DH}	60		80		ns
$t_h(RLD)$ Data hold time after \overline{RAS} low	t_{DHR}	110		145		ns
$t_h(WLD)$ Data hold time after \overline{W} low	t_{DH}	45		55		ns
$t_h(CHrd)$ Read-command hold time after \overline{CAS} high	t_{RCH}	0		0		ns

(Continued next page.)

NOTE 6: Timing measurements are made at the 10% and 90% points of input and clock transitions. In addition, V_{IL} max and V_{IH} min must be met at the 10% and 90% points.

[†]All cycle times assume $t_t = 5$ ns except $t_{c(SCLK)}$ which assumes $t_t = 3$ ns.

[‡]Multiple transfer write cycles require separation by either a 500 ns \overline{RAS} precharge interval or any other active \overline{RAS} cycle.

[§]Page-mode only.

[¶]In a read-modify-write cycle, t_{CLWL} and $t_{su(WCH)}$ must be observed. Depending on the user's transition times, this may require additional \overline{CAS} low time ($t_{w(CL)}$). This applies to page-mode read-modify-write also.

[#]In a read-modify-write cycle, t_{RLWL} and $t_{su(WRH)}$ must be observed. Depending on the user's transition times, this may require additional \overline{RAS} low time ($t_{w(RL)}$).

4
Dynamic RAMs

TMS4161

65,536-BIT MULTIPORT VIDEO RAM

timing requirements over recommended supply voltage range and operating free-air temperature range (concluded)

	ALT. SYMBOL	TMS4161-15		TMS4161-20		UNIT
		MIN	MAX	MIN	MAX	
$t_{h(RHrd)}$ Read-command hold time after \overline{RAS} high	t_{RRH}	5		5		ns
$t_{h(CLW)}$ Write-command hold time after \overline{CAS} low	t_{WCH}	60		80		ns
$t_{h(RLW)}$ Write-command hold time after \overline{RAS} low	t_{WCR}	110		145		ns
$t_{h(RSO)}$ Serial-data-out hold time after \overline{RAS} low with $\overline{TR}/\overline{OE}$ low		30		30		ns
$t_{h(SO)}$ Serial-data-out hold time after SCLK high		8		8		ns
$t_{h(TR)}$ $\overline{TR}/\overline{OE}$ hold time after \overline{RAS} low (transfer)		20		20		ns
t_{RLCH} Delay time, \overline{RAS} low to \overline{CAS} high	t_{CSH}	150		200		ns
t_{CHRL} Delay time, \overline{CAS} high to \overline{RAS} low	t_{CRP}	0		0		ns
t_{CLQEH} Delay time, \overline{CAS} low to \overline{OE} high		100		135		ns
t_{CLRH} Delay time, \overline{CAS} low to \overline{RAS} high	t_{RSH}	100		135		ns
t_{CLWL} Delay time, \overline{CAS} low to \overline{W} low (read-modify-write cycle only)	t_{CWD}	65		75		ns
t_{CQE} Delay time, \overline{CAS} low to \overline{OE} low (maximum value specified only to guarantee $t_a(QE)$ access time)			60		85	ns
t_{RHSC} Delay time, \overline{RAS} high to SCLK high		80	50,000	80	50,000	ns
t_{RLCL} Delay time, \overline{RAS} low to \overline{CAS} low (maximum value specified only to guarantee access time)	t_{RCD}	25	50	30	65	ns
t_{RLWL} Delay time, \overline{RAS} low to \overline{W} low (read-modify-write cycle only)	t_{RWD}	135		150		ns
t_{CKRL} Delay time, SCLK high before \overline{RAS} low with $\overline{TR}/\overline{OE}$ low [‡]		10	50,000	10	50,000	ns
$t_{rf}(MA)$ Refresh time interval, memory array	t_{REF1}		4		4	ms
$t_{rf}(SR)$ Refresh time interval, shift register ^{‡‡}	t_{REF2}		50,000		50,000	ns

NOTE 6: Timing measurements are made at the 10% and 90% points of input and clock transitions. In addition, V_{IL} max and V_{IH} min must be met at the 10% and 90% points.

[‡]SCLK may be high or low during $t_{w(RL)}$, but there can not be any positive edge transitions on SCLK for a minimum of 10 ns prior to \overline{RAS} going low with $\overline{TR}/\overline{OE}$ low (i.e., before a transfer cycle).

^{‡‡}See "refresh" on page 4-22.

PARAMETER MEASUREMENT INFORMATION

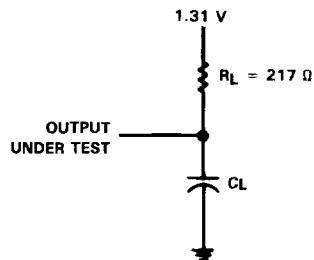
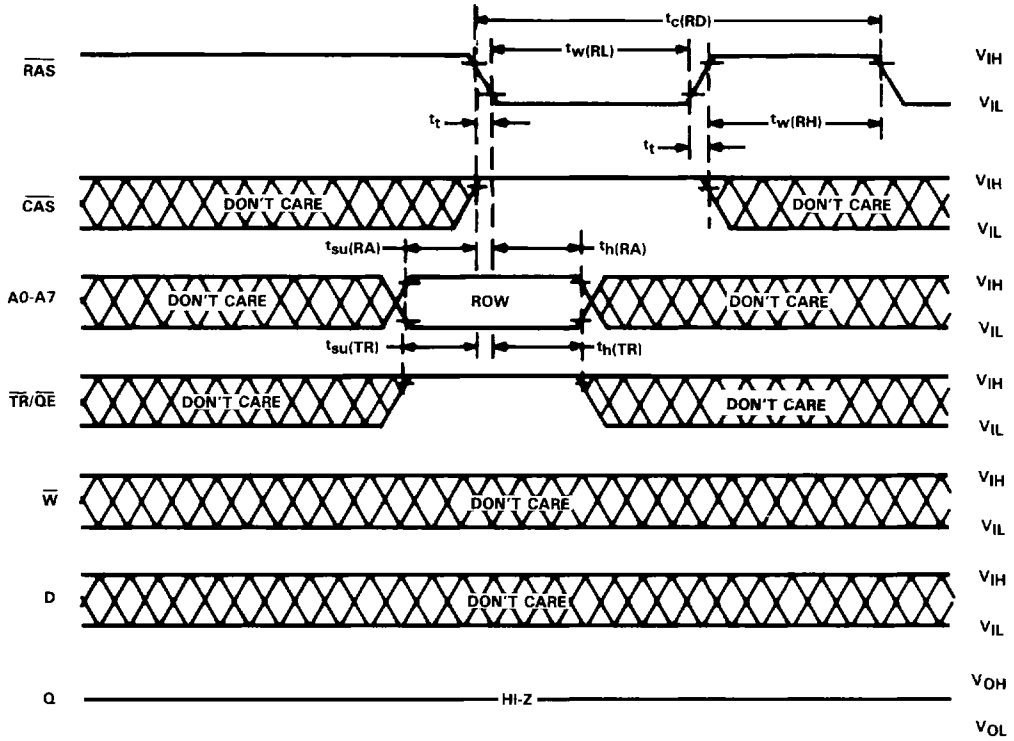

FIGURE 1. LOAD CIRCUIT

TMS4161
65,536-BIT MULTIPORT VIDEO RAM

RAS-only refresh timing



4
Dynamic RAMs

shift register to memory timing

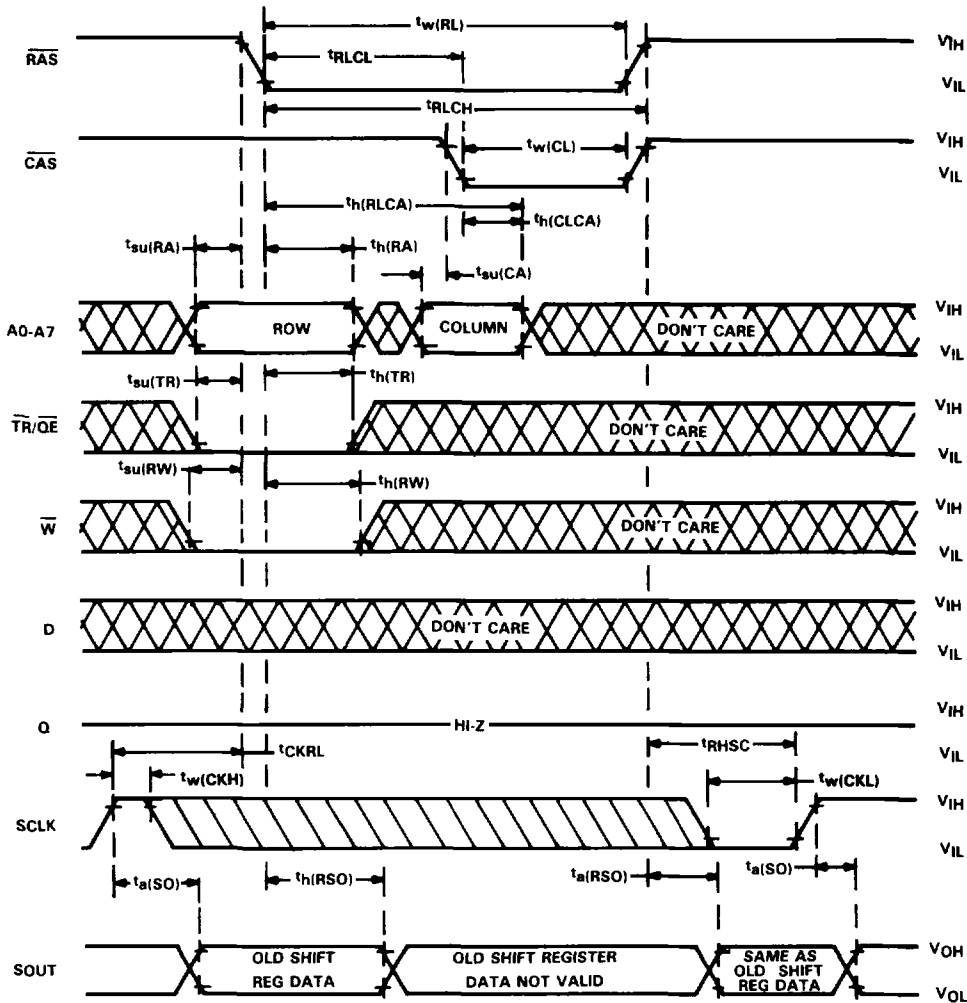

NOTES: 11. The shift register to memory cycle is used to transfer data from the shift register to the memory array. Every one of the 256 locations in the shift register is written into the 256 columns of the selected row. Note that the data that was in the shift register may have resulted, either from a serial shift in or from a parallel load of the shift register from one of the memory array rows.

12. SOE assumed low.

13. SCLK may be high or low during $t_w(RL)$.

TMS4161
65,536-BIT MULTIPOINT VIDEO RAM

memory to shift register timing

4
Dynamic RAMS

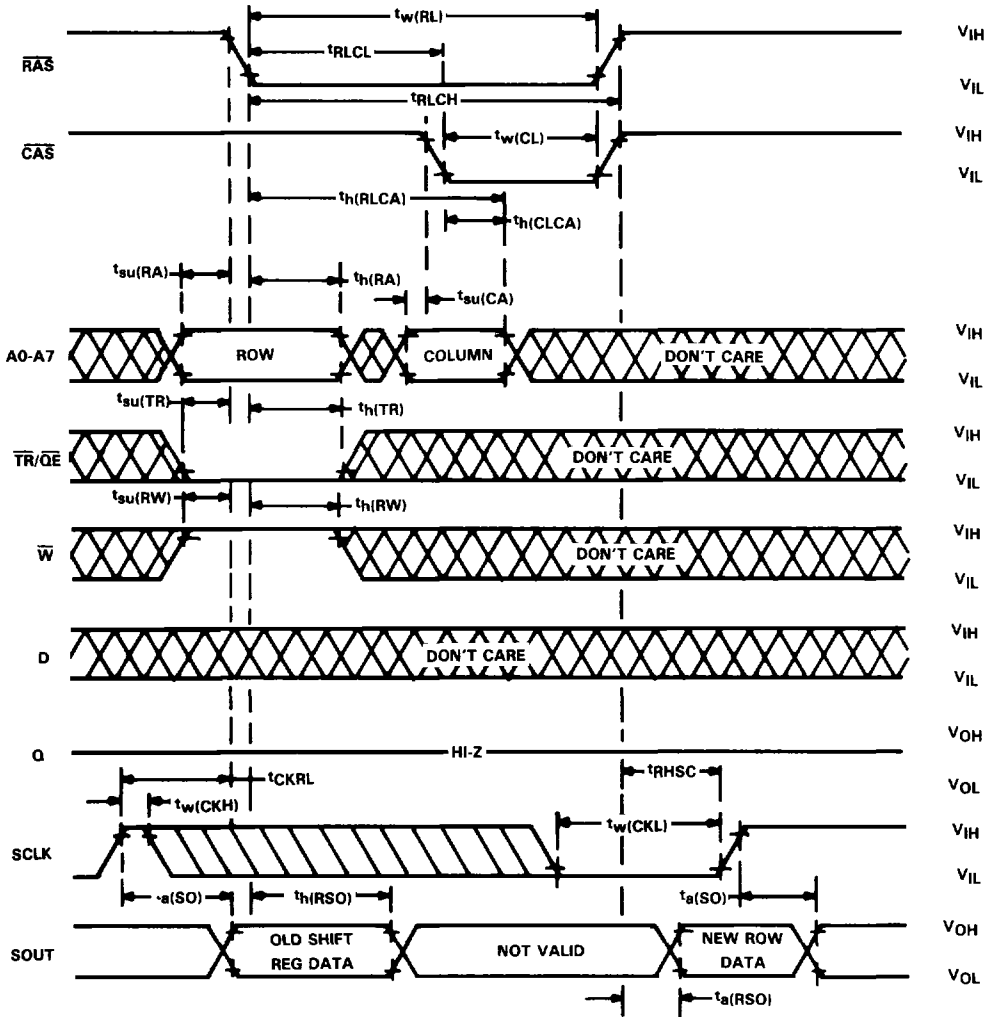

NOTES: 12. \overline{SOE} assumed low.

13. SCLK may be high or low during $t_w(RL)$.

14. The memory to shift register cycle is used to load the shift register in parallel from the memory array. Every one of the 256 locations in the shift register are written into from the 256 columns of the selected row. Note that the data that is loaded into the shift register may be either shifted out or written back into another row.

serial data shift timing

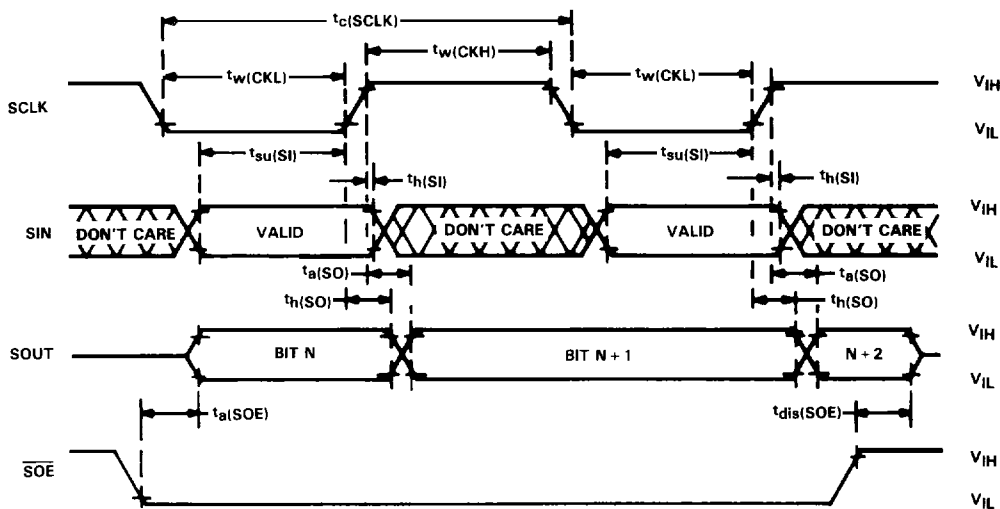

4

Dynamic RAMs

- NOTES: 15. When loading data into the shift register from the serial input in preparation for a shift register to memory transfer operation, the serial clock must be clocked an even number of times.
16. While shifting data through the serial shift register, the state of $\overline{\text{TR}}/\overline{\text{OE}}$ is a don't care as long as $\overline{\text{TR}}/\overline{\text{OE}}$ is held high when $\overline{\text{RAS}}$ goes low and $t_{su}(\text{TR})$ and $t_h(\text{TR})$ timings are observed. This requirement avoids the initiation of a register-to-memory or memory-to-register data transfer operation. The serial data transfer cycle is used to shift data in and/or out of the shift register.

TMS4161
65,536-BIT MULTIPORT VIDEO RAM

4
Dynamic RAMS

shift register to memory multiple timing

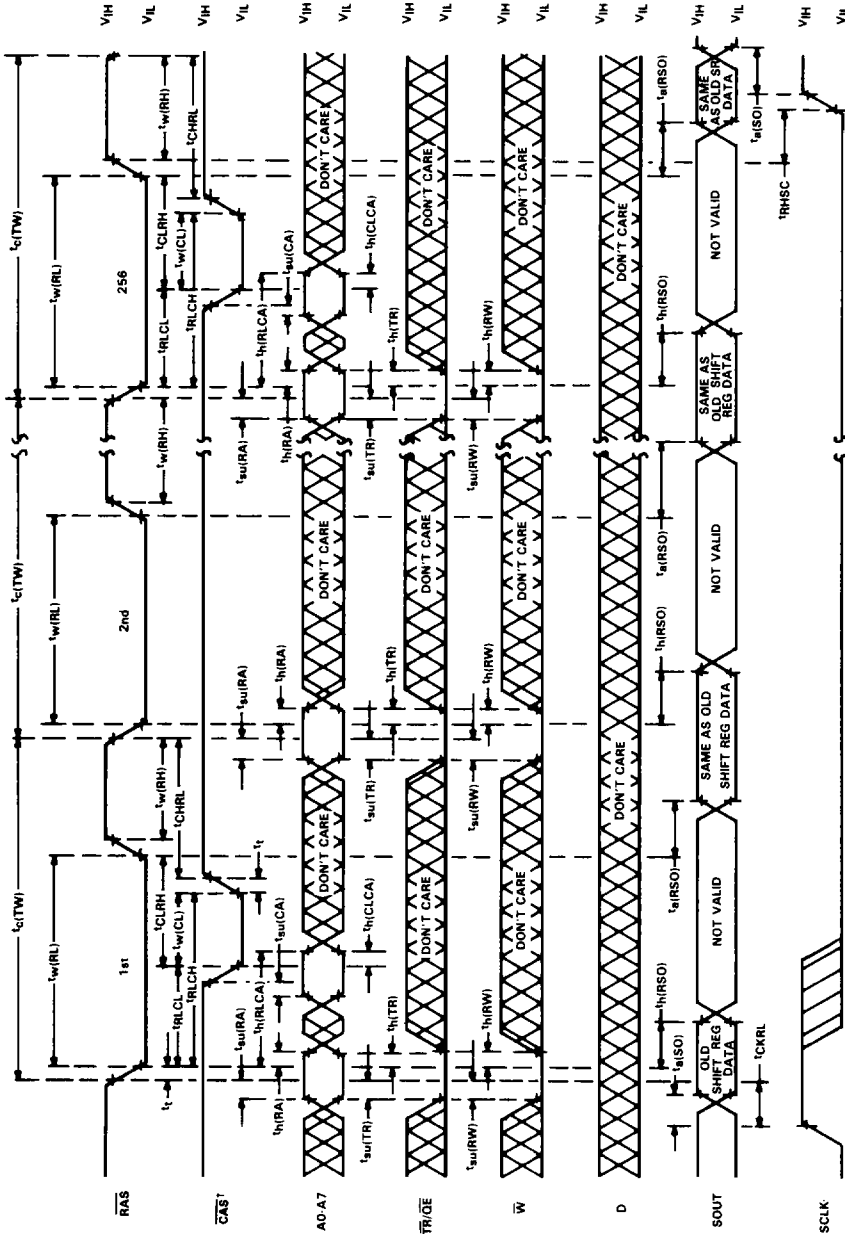

t_{CAS} and register address need not be supplied every cycle, only when it is desired to change or select a new register length.

NOTES: 12. S_{OE} assumed low.

17. The shift register to memory multiple cycle is used to write the shift register data to more than one row of the memory array. An application of this could be clearing all memory. To do this, the SIN line would be held at 0 to fill all locations in the shift register with 0's. The shift register would then be written into all 256 rows of the memory array in 256 cycles. The random output port Q will be in a high impedance state as long as register transfer cycles are selected.

18. $SCLK$ is a don't care except that no positive transitions on $SCLK$ can occur for a period equal to t_{CKRL} prior to RAS falling with TR/DE low.

memory to shift register to memory multiple timing

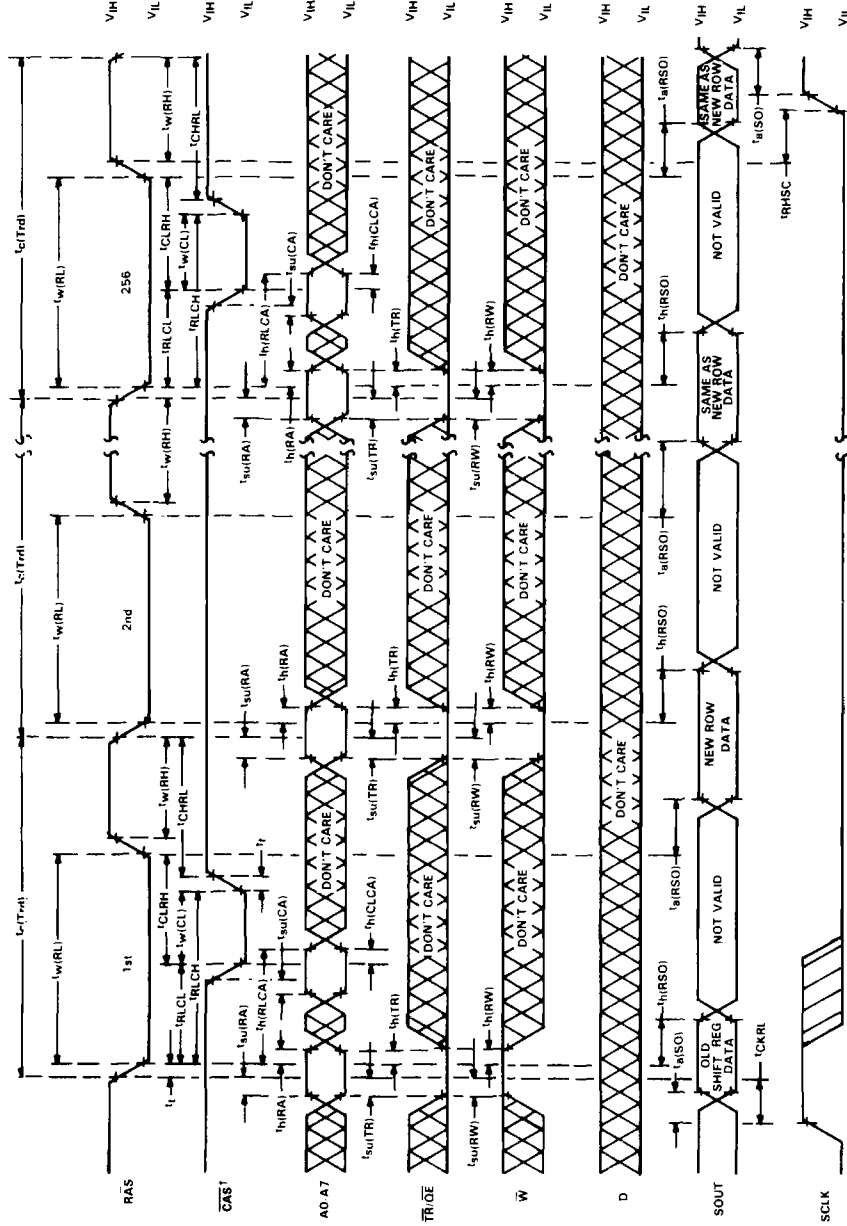

t_{CAS} and register address need not be supplied every transfer cycle, only when it is desired to change from one register address to another.

NOTES: 12. t_{SOE} assumed low.

- 18. SCLK is a don't care except that no positive transitions on SCLK can occur for a period equal to t_{CKRL} prior to RAS falling with TR/OE low.
- 19. The memory to shift register to memory multiple cycle is used to reorder the rows within the memory array itself. First, the data in a row is stored in the shift register and then it is written into other selected rows. The random output port Q will be in a high-impedance state as long as register transfer cycles are selected.

TMS4161
65,536-BIT MULTIPORT VIDEO RAM

4

Dynamic RAMs

