

2SC5094

SILICON NPN EPITAXIAL PLANAR TYPE TRANSISTOR

VHF~UHF BAND LOW NOISE AMPLIFIER APPLICATIONS.

- Low Noise Figure, High Gain.
- $NF = 1.8\text{dB}$, $|S_{21e}|^2 = 7.5\text{dB}$ ($f = 2\text{GHz}$)

MAXIMUM RATINGS ($T_a = 25^\circ\text{C}$)

CHARACTERISTIC	SYMBOL	RATING	UNIT
Collector-Base Voltage	V_{CB0}	20	V
Collector-Emitter Voltage	V_{CEO}	10	V
Emitter-Base Voltage	V_{EBO}	1.5	V
Base Current	I_B	7	mA
Collector Current	I_C	15	mA
Collector Power Dissipation	P_C	150	mW
Junction Temperature	T_j	125	$^\circ\text{C}$
Storage Temperature Range	T_{stg}	-55~125	$^\circ\text{C}$

MARKING

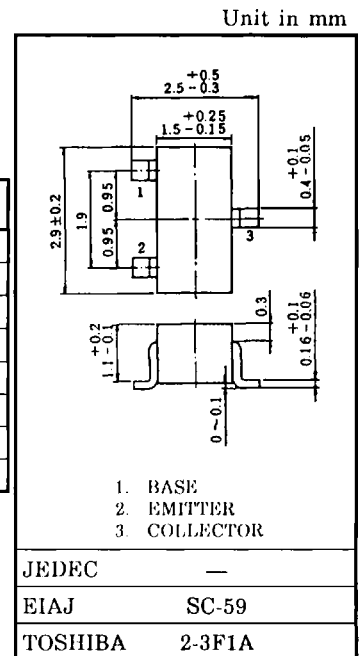
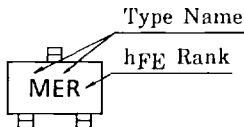

Weight : 0.012g

MICROWAVE CHARACTERISTICS ($T_a = 25^\circ\text{C}$)

CHARACTERISTIC	SYMBOL	TEST CONDITION	MIN.	TYP.	MAX.	UNIT
Transition Frequency	f_T	$V_{CE} = 6\text{V}$, $I_C = 7\text{mA}$	7	10	—	GHz
Insertion Gain	$ S_{21e} ^2$ (1)	$V_{CE} = 6\text{V}$, $I_C = 7\text{mA}$, $f = 1\text{GHz}$	—	13	—	dB
	$ S_{21e} ^2$ (2)	$V_{CE} = 6\text{V}$, $I_C = 7\text{mA}$, $f = 2\text{GHz}$	4.5	7.5	—	
Noise Figure	NF (1)	$V_{CE} = 6\text{V}$, $I_C = 3\text{mA}$, $f = 1\text{GHz}$	—	1.4	—	dB
	NF (2)	$V_{CE} = 6\text{V}$, $I_C = 3\text{mA}$, $f = 2\text{GHz}$	—	1.8	3.0	

ELECTRICAL CHARACTERISTICS ($T_a = 25^\circ\text{C}$)

CHARACTERISTIC	SYMBOL	TEST CONDITION	MIN.	TYP.	MAX.	UNIT
Collector Cut-off Current	I_{CBO}	$V_{CB} = 10\text{V}$, $I_E = 0$	—	—	1	μA
Emitter Cut-off Current	I_{EBO}	$V_{EB} = 1\text{V}$, $I_C = 0$	—	—	1	μA
DC Current Gain	h_{FE} ^{Note}	$V_{CE} = 6\text{V}$, $I_C = 7\text{mA}$	50	—	160	—
Output Capacitance	C_{ob}	$V_{CB} = 10\text{V}$, $I_E = 0$, $f = 1\text{MHz}$ (Note)	—	0.5	—	pF
Reverse Transfer Capacitance	C_{re}		—	0.4	0.85	pF

Note : C_{re} is measured by 3 terminal method with capacitance bridge.

Note : h_{FE} Classification R : 50~100, O : 80~160

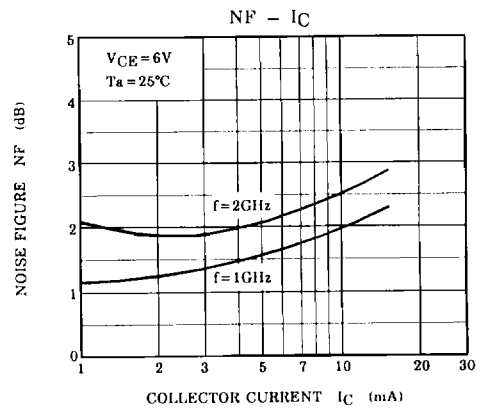
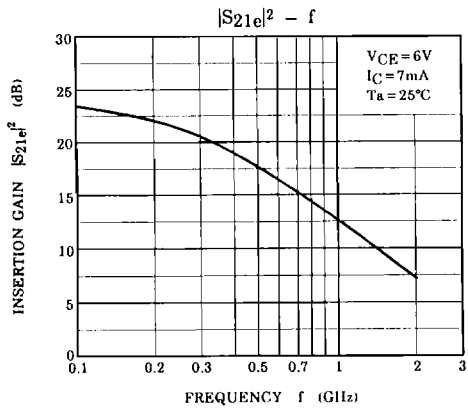
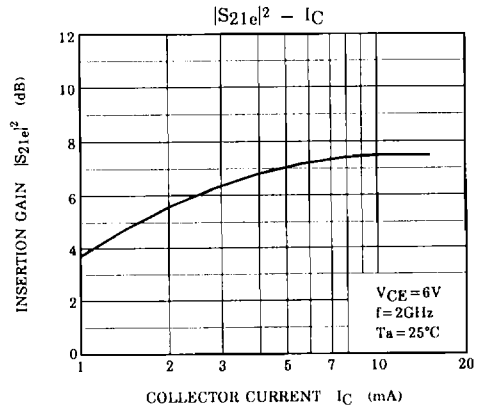
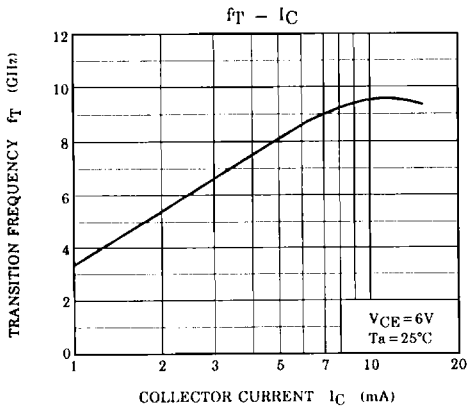
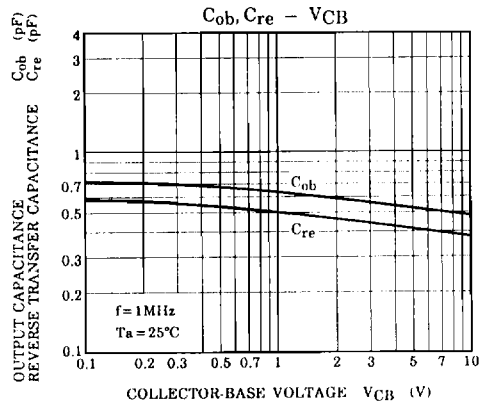
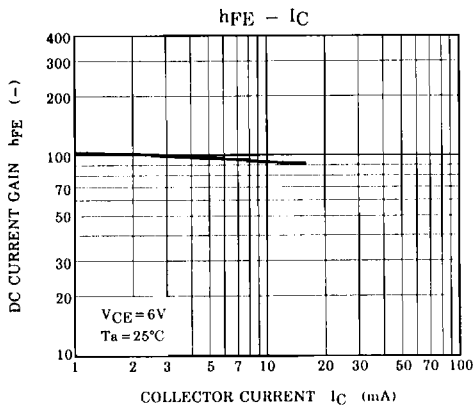

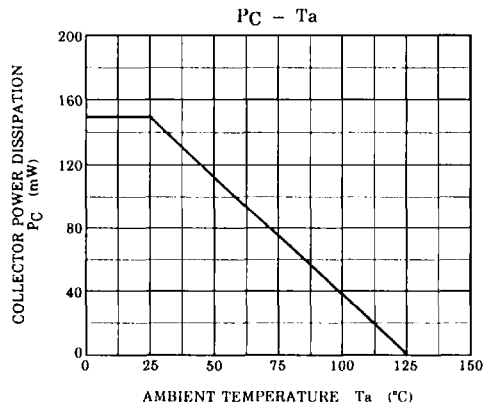
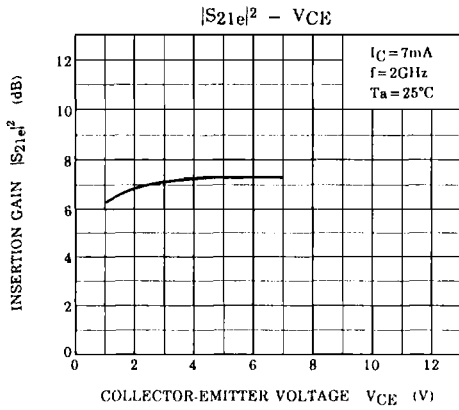

S-Parameter $Z_0 = 50\Omega$, $T_a = 25^\circ\text{C}$
 $V_{CE} = 6\text{V}$, $I_C = 3\text{mA}$

frequency (MHz)	S11		S21		S12		S22	
	Mag.	Ang.	Mag.	Ang.	Mag.	Ang.	Mag.	Ang.
200	0.817	-25.8	7.113	150.2	0.044	71.4	0.898	-18.6
400	0.647	-46.3	6.028	129.5	0.073	61.8	0.746	-28.7
600	0.477	-61.4	5.061	113.9	0.092	57.2	0.636	-33.4
800	0.356	-71.3	4.197	102.8	0.108	55.7	0.565	-35.4
1000	0.265	-78.9	3.583	93.9	0.123	55.3	0.518	-36.8
1200	0.194	-85.6	3.135	86.7	0.137	55.7	0.486	-37.5
1400	0.136	-90.5	2.778	80.2	0.153	55.8	0.467	-38.8
1600	0.093	-97.7	2.490	74.4	0.169	55.3	0.449	-40.4
1800	0.058	-109.0	2.260	69.6	0.183	54.8	0.433	-42.6
2000	0.028	-134.7	2.089	65.2	0.199	55.2	0.418	-43.9

$V_{CE} = 6\text{V}$, $I_C = 7\text{mA}$

frequency (MHz)	S11		S21		S12		S22	
	Mag.	Ang.	Mag.	Ang.	Mag.	Ang.	Mag.	Ang.
200	0.630	-39.7	12.332	138.1	0.037	68.5	0.783	-25.6
400	0.392	-64.1	8.847	114.7	0.059	64.3	0.586	-31.8
600	0.248	-78.3	6.514	101.4	0.077	64.1	0.495	-32.0
800	0.161	-87.5	5.094	92.6	0.096	64.7	0.449	-31.2
1000	0.105	-95.3	4.213	85.9	0.114	64.9	0.423	-30.5
1200	0.060	-106.3	3.589	80.3	0.133	65.0	0.412	-30.8
1400	0.028	-121.7	3.139	74.9	0.154	64.0	0.406	-32.1
1600	0.021	-158.4	2.786	70.1	0.173	62.5	0.398	-34.0
1800	0.035	171.6	2.498	66.0	0.190	61.2	0.387	-36.7
2000	0.054	144.0	2.300	62.3	0.210	60.7	0.377	-38.4

S_{11e}
 V_{CE} = 6V
 I_C = 3mA
 T_a = 25°C
 (UNIT : Ω)

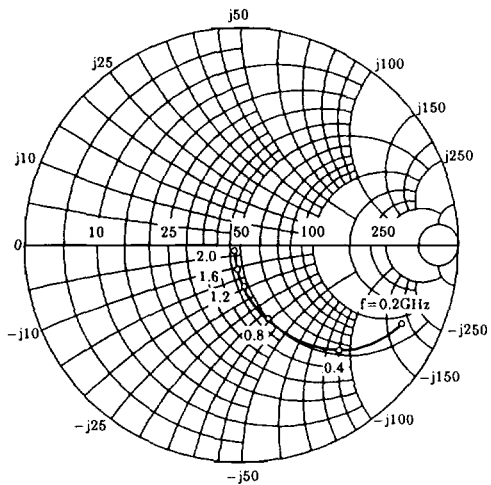

S_{21e}
 V_{CE} = 6V
 I_C = 3mA
 T_a = 25°C

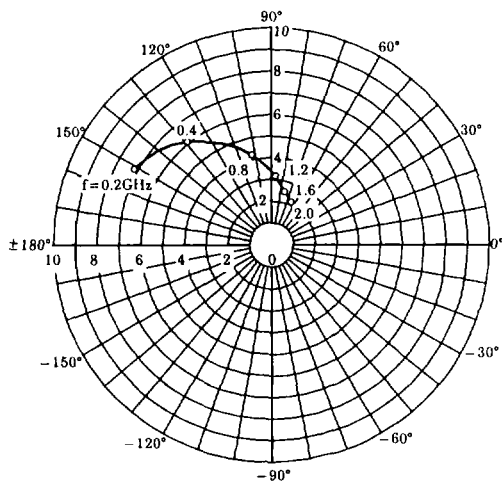

S_{12e}
 V_{CE} = 6V
 I_C = 3mA
 T_a = 25°C

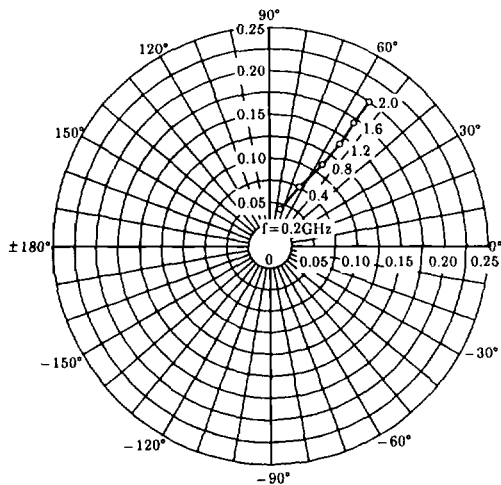

S_{22e}
 V_{CE} = 6V
 I_C = 3mA
 T_a = 25°C
 (UNIT : Ω)

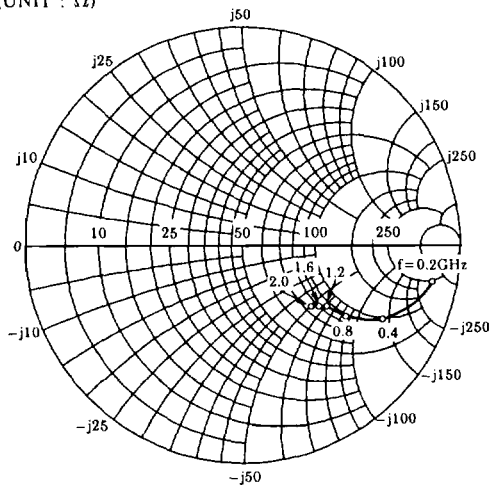

S11e
 VCE = 6V
 IC = 7mA
 Ta = 25°C
 (UNIT : Ω)

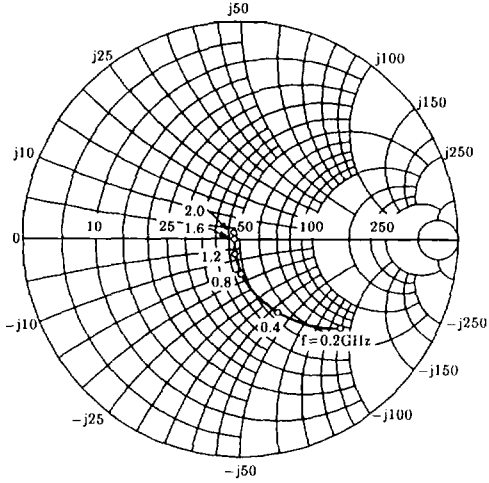

S21e
 VCE = 6V
 IC = 7mA
 Ta = 25°C

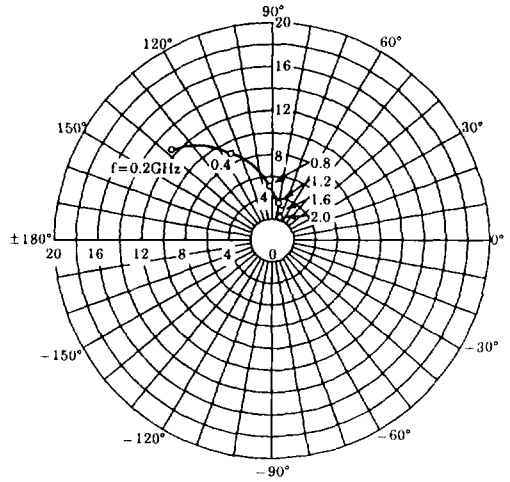

S12e
 VCE = 6V
 IC = 7mA
 Ta = 25°C

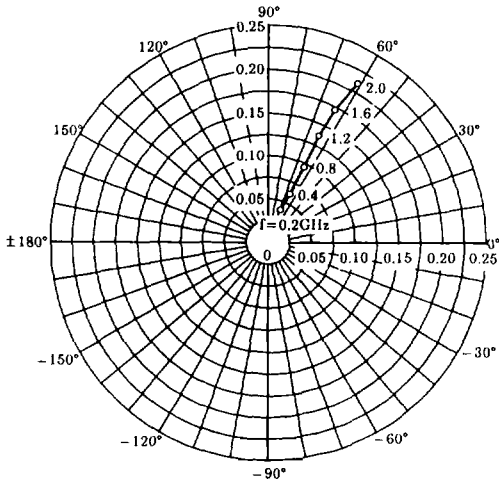

S22e
 VCE = 6V
 IC = 7mA
 Ta = 25°C
 (UNIT : Ω)

