

**FEATURES**

- 14-Bit resolution
- 5MHz minimum sampling rate
- No missing codes over full military temperature range
- Edge-triggered, no pipeline delay
- Low power, 2.95 Watts
- Small, 32-pin, ceramic TDIP package
- SMT package available
- Excellent dynamic performance
- MIL-STD-883 screening or DESC SMD available

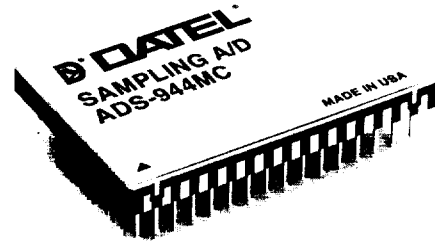

**GENERAL DESCRIPTION**

The low-cost ADS-944 is a high-performance, 14-bit, 5MHz sampling A/D converter. This device accurately samples full-scale input signals up to Nyquist frequencies with no missing codes. The dynamic performance of the ADS-944 has been optimized to achieve a THD of -77dB and a SNR of 76dB.

Packaged in a small, 32-pin TDIP, the functionally complete ADS-944 contains a fast-settling sample-hold amplifier, a subranging (two-pass) A/D converter, an internal reference, timing and control logic, three-state outputs, and error-correction circuitry. Digital input and output levels are TTL.

Requiring ±15V, +5V and -5.2V supplies, the ADS-944 typically dissipates 2.95 Watts. The unit is offered with a bipolar input range of ±1.25V. Models are available for use in either commercial (0 to +70°C) or military (-55 to +125°C) operating temperature ranges. Typical applications include radar signal analysis, medical/graphic imaging, and FFT spectrum analysis.

**INPUT/OUTPUT CONNECTIONS**

PIN	FUNCTION	PIN	FUNCTION
1	+5V ANALOG SUPPLY	32	START CONVERT
2	-5.2V DIGITAL SUPPLY	31	BIT 1 (MSB)
3	ANALOG INPUT	30	BIT 1 (MSB)
4	ANALOG GROUND	29	BIT 2
5	OFFSET ADJUST	28	BIT 3
6	ANALOG GROUND	27	BIT 4
7	GAIN ADJUST	26	BIT 5
8	COMP. BITS	25	BIT 6
9	OUTPUT ENABLE	24	BIT 7
10	+5V DIGITAL SUPPLY	23	BIT 8
11	ANALOG GROUND	22	BIT 9
12	+15V SUPPLY	21	BIT 10
13	-15V SUPPLY	20	BIT 11
14	-5.2V ANALOG SUPPLY	19	BIT 12
15	DIGITAL GROUND	18	BIT 13
16	EOC	17	BIT 14 (LSB)

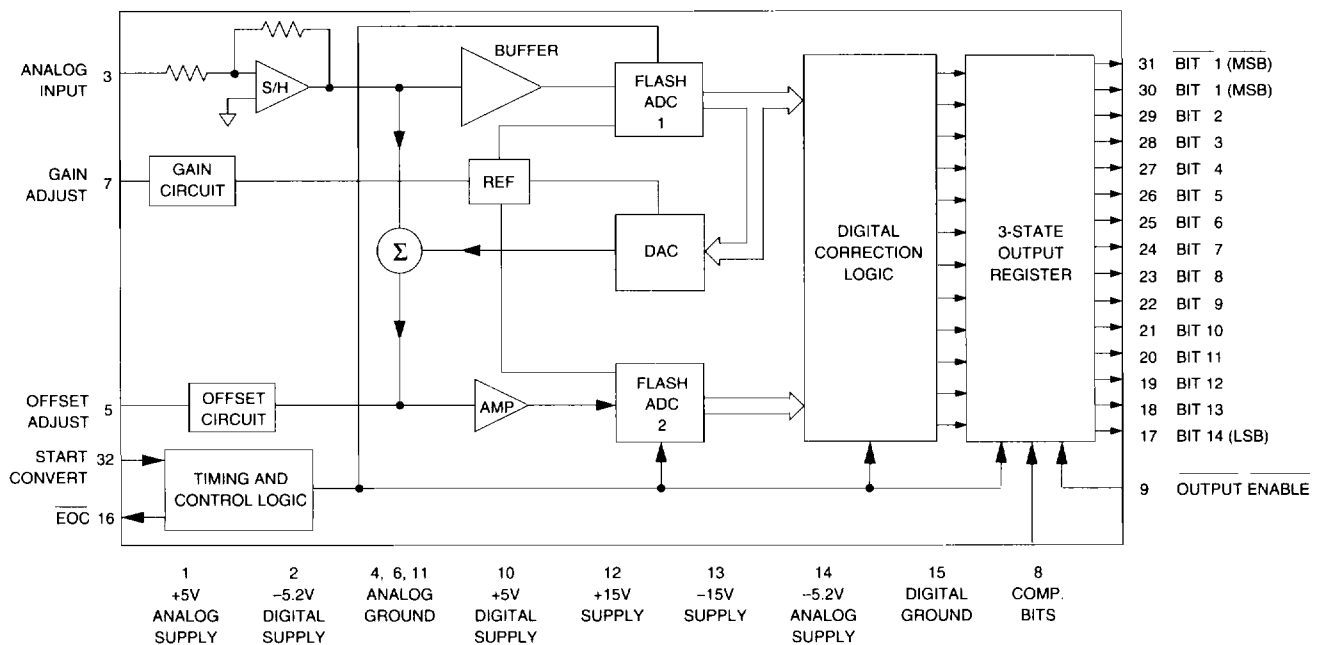

Figure 1. ADS-944 Functional Block Diagram

**ABSOLUTE MAXIMUM RATINGS**

PARAMETERS	LIMITS	UNITS
+15V Supply (Pin 12)	0 to +16	Volts
-15V Supply (Pin 13)	0 to -16	Volts
+5V Supply (Pins 1, 10)	0 to +6	Volts
-5.2V Supply (Pins 2, 14)	0 to -6	Volts
Digital Inputs (Pins 8, 9, 32)	-0.3 to +V <sub>DD</sub> +0.3	Volts
Analog Input (Pin 3)	-5 to +5	Volts
Lead Temp. (10 seconds)	300	°C

**PHYSICAL/ENVIRONMENTAL**

PARAMETERS	MIN.	TYP.	MAX.	UNITS
Operating Temp. Range, Case	0	—	+70	°C
	-55	—	+125	°C
Thermal Impedance	—	7	—	°C/Watt
	—	21	—	°C/Watt
Storage Temperature Range	-65	—	+150	°C
Package Type	32-pin, metal-sealed, ceramic TDIP or SMT			
Weight	0.46 ounces (13 grams)			

**FUNCTIONAL SPECIFICATIONS**

(T<sub>A</sub> = +25°C, ±V<sub>CC</sub> = ±15V, +V<sub>DD</sub> = +5V, -V<sub>DD</sub> = -5.2V, 5MHz sampling rate, and a minimum 3 minute warmup <sup>††</sup> unless otherwise specified.)

ANALOG INPUT	+25°C			0 to +70°C			-55 to +125°C			UNITS
	MIN.	TYP.	MAX.	MIN.	TYP.	MAX.	MIN.	TYP.	MAX.	
Input Voltage Range	—	±1.25	—	—	±1.25	—	—	±1.25	—	Volts
Input Resistance	500	550	—	500	550	—	500	550	—	Ω
Input Capacitance	—	6	15	—	6	15	—	6	15	pF
<b>DIGITAL INPUTS</b>										
Logic Levels										
Logic "1"	+2.0	—	—	+2.0	—	—	+2.0	—	—	Volts
Logic "0"	—	—	+0.8	—	—	+0.8	—	—	+0.8	Volts
Logic Loading "1"	—	—	+20	—	—	+20	—	—	+20	μA
Logic Loading "0" <sup>②</sup>	—	—	-20	—	—	-20	—	—	-20	μA
Start Convert Positive Pulse Width <sup>③</sup>	40	80	—	40	80	—	40	80	—	ns
<b>STATIC PERFORMANCE</b>										
Resolution	—	14	—	—	14	—	—	14	—	Bits
Integral Nonlinearity (f <sub>in</sub> = 10kHz)	—	±0.75	—	—	±0.75	—	—	±1.0	—	LSB
Differential Nonlinearity (f <sub>in</sub> = 10kHz)	-0.95	±0.5	+1.2	-0.95	±0.5	+1.2	-0.95	±0.5	+1.5	LSB
Full Scale Absolute Accuracy	—	±0.15	±0.4	—	±0.15	±0.4	—	±0.4	±0.8	%FSR
Bipolar Zero Error (Tech Note 2)	—	±0.1	±0.3	—	±0.1	±0.3	—	±0.3	±0.6	%FSR
Bipolar Offset Error (Tech Note 2)	—	±0.2	±0.4	—	±0.2	±0.4	—	±0.3	±0.9	%FSR
Gain Error (Tech Note 2)	—	±0.2	±0.4	—	±0.2	±0.4	—	±0.4	±1.5	%
No Missing Codes (f <sub>in</sub> = 10kHz)	14	—	—	14	—	—	14	—	—	Bits
<b>DYNAMIC PERFORMANCE</b>										
Peak Harmonics (-0.5dB)										
dc to 100kHz	—	-85	-77	—	-85	-75	—	-81	-71	dB
100kHz to 1MHz	—	-78	-71	—	-78	-70	—	-75	-67	dB
1MHz to 2.5MHz	—	-75	-70	—	-75	-68	—	-71	-61	dB
Total Harmonic Distortion (-0.5dB)										
dc to 100kHz	—	-82	-76	—	-82	-74	—	-78	-70	dB
100kHz to 1MHz	—	-77	-70	—	-77	-70	—	-73	-65	dB
1MHz to 2.5MHz	—	-73	-68	—	-73	-65	—	-70	-60	dB
Signal-to-Noise Ratio										
(w/o distortion, -0.5dB)										
dc to 100kHz	73	76	—	73	76	—	71	75	—	dB
100kHz to 1MHz	73	76	—	73	76	—	71	75	—	dB
1MHz to 2.5MHz	73	75	—	73	75	—	71	75	—	dB
Signal-to-Noise Ratio <sup>④</sup>										
(& distortion, -0.5dB)										
dc to 100kHz	71	75	—	71	75	—	68	73	—	dB
100kHz to 1MHz	70	73	—	69	73	—	65	71	—	dB
1MHz to 2.5MHz	68	71	—	66	71	—	62	69	—	dB
Noise	—	135	—	—	135	—	—	135	—	μVrms
Two-tone Intermodulation										
Distortion (f <sub>in</sub> = 2.45MHz, 1.975MHz, f <sub>s</sub> = 5MHz, -0.5dB)	—	-82	—	—	-82	—	—	-82	—	dB
Input Bandwidth (-3dB)										
Small Signal (-20dB input)	—	20	—	—	20	—	—	20	—	MHz
Large Signal (-0dB input)	—	13	—	—	13	—	—	13	—	MHz
Feedthrough Rejection (f <sub>in</sub> = 2.5MHz)	—	90	—	—	90	—	—	90	—	dB
Slew Rate	—	±110	—	—	±110	—	—	±110	—	V/μs
Aperture Delay Time	—	±10	—	—	±10	—	—	±10	—	ns
Aperture Uncertainty	—	3	—	—	3	—	—	3	—	ps rms
S/H Acquisition Time	—	85	90	—	85	90	—	85	90	ns
(to ±0.003%FSR, 2.5V step)	—	85	90	—	85	90	—	85	90	ns
Overshoot Recovery Time <sup>⑤</sup>	—	200	—	—	200	—	—	200	—	ns
A/D Conversion Rate	5	—	—	5	—	—	5	—	—	MHz

DIGITAL OUTPUTS	+25°C			0 to +70°C			-55 to +125°C			UNITS
	MIN.	TYP.	MAX.	MIN.	TYP.	MAX.	MIN.	TYP.	MAX.	
<b>Logic Levels</b>										
Logic "1"	+2.4	—	—	+2.4	—	—	+2.4	—	—	Volts
Logic "0"	—	—	+0.4	—	—	+0.4	—	—	+0.4	Volts
Logic Loading "1"	—	—	-4	—	—	-4	—	—	-4	mA
Logic Loading "0"	—	—	+4	—	—	+4	—	—	+4	mA
<b>Delay, Edge of ENABLE to Output Data Valid/Invalid</b>	—	—	10	—	—	10	—	—	10	ns
<b>Output Coding</b>	Offset Binary, Complementary Offset Binary, Two's Complement									
<b>POWER REQUIREMENTS</b>										
<b>Power Supply Ranges ⑥</b>										
+15V Supply	+14.25	+15.0	+15.75	+14.25	+15.0	+15.75	+14.25	+15.0	+15.75	Volts
-15V Supply	-14.25	-15.0	-15.75	-14.25	-15.0	-15.75	-14.25	-15.0	-15.75	Volts
+5V Supply	+4.75	+5.0	+5.25	+4.75	+5.0	+5.25	+4.9	+5.0	+5.25	Volts
-5.2V Supply	-4.95	-5.2	-5.45	-4.95	-5.2	-5.45	-5.1	-5.2	-5.45	Volts
<b>Power Supply Currents ⑦</b>										
+15V Supply	—	+36	+45	—	+36	+45	—	+36	+45	mA
-15V Supply	—	-55	-65	—	-55	-65	—	-55	-65	mA
+5V Supply	—	+155	+168	—	+155	+168	—	+155	+168	mA
-5.2V Supply	—	-167	-175	—	-167	-175	—	-167	-175	mA
<b>Power Dissipation</b>	—	2.95	3.3	—	2.95	3.3	—	2.95	3.3	Watts
<b>Power Supply Rejection</b>	—	—	±0.05	—	—	±0.05	—	—	±0.05	%FSR/%V
<b>Footnotes:</b>										
① All power supplies should be on before applying a start convert pulse. All supplies and the clock (start convert pulses) must be present during warmup periods. The device must be continuously converting during this time.					⑤ This is the time required before the A/D output is valid after the analog input is back within its specified range.					
② When COMP. BITS (pin 8) is low, logic loading "0" will be -350µA for this pin.					⑥ The minimum supply voltages of +4.9V and -5.1V for ±V <sub>DD</sub> are required for -55°C operation only. The minimum limits are +4.75V and -4.95V when operating at +125°C.					
③ An 80ns wide start convert pulse is used for all production testing. The start convert pulse should be between 40 – 80ns or 130 – 160ns to ensure proper operation. The latter range could be used for those applications requiring less than a 5MHz sampling rate.					⑦ Typical +5V and -5.2V current drain breakdowns are as follows:					
④ Effective bits is equal to: $\frac{(SNR + Distortion) - 1.76 + 20 \log \left( \frac{\text{Full Scale Amplitude}}{\text{Actual Input Amplitude}} \right)}{6.02}$					+5V <sub>Analog</sub> = +85mA		-5.2V <sub>Analog</sub> = -114mA			
					+5V <sub>Digital</sub> = +70mA		-5.2V <sub>Digital</sub> = -53mA			
					+5V <sub>Total</sub> = +155mA		-5.2V <sub>Total</sub> = -167mA			

**TECHNICAL NOTES**

- Obtaining fully specified performance from the ADS-944 requires careful attention to pc-card layout and power supply decoupling. The device's analog and digital ground systems are *not* connected to each other internally. For optimal performance, tie all ground pins (4, 6, 11, and 15) directly to a large **analog** ground plane beneath the package. Bypass all power supplies to ground with 4.7µF tantalum capacitors in parallel with 0.1µF ceramic capacitors. **It is very important that the bypass capacitors be located as close to the unit as possible.** Inductors or ferrite beads can also be used to improve the power supply filtering. Refer to Figure 4, the ADS-944 Evaluation Board Schematic, for more details.
- The ADS-944 achieves its specified accuracies without the need for external calibration. If required, the device's small initial offset and gain errors can be reduced to zero using the adjustment circuitry shown in Figure 2. When using this circuitry, or any similar offset and gain-calibration hardware, make adjustments following warmup. To avoid interaction, always adjust offset before gain.
- Pin 8 (COMP. BITS) selects the ADS-944's digital output coding. When a logic "1" is applied to pin 8, the output coding is complementary offset binary. When pin 8 has a logic "0" applied, the output coding becomes offset binary. The MSB output (pin 31) may be used under these conditions to achieve

two's complement coding. Pin 8 is TTL-compatible and can be driven with digital logic for those who want dynamic control of its function. There is an internal pull-up resistor on this pin, allowing pin 8 to be either connected to +5V or left open when a logic "1" is needed.

- To enable the three-state outputs, apply a logic "0" (low) to OUTPUT ENABLE (pin 9). To disable, apply a logic "1" (high) to pin 9.
- Applying a start convert pulse while a conversion is in progress (EOC = logic "1") initiates a new and inaccurate conversion cycle. Data for the interrupted and subsequent conversions will be invalid.
- A passive bandpass filter is used at the input of the A/D for all production testing.
- Though the ADS-944's digital outputs are capable of driving multiple LSTTL or HCT loads, we recommend the output bits and the EOC line each drive only a single gate. These gates should be located as close to the unit as possible. If they can not, 33Ω resistors placed in series with each output can aid in isolating pc run inductances. The ADS-944 digital outputs should not be connected directly to noisy digital busses.
- Do not enable/disable or complement the output bits during the conversion process (from the falling edge of START CONVERT to the falling edge of EOC).

**CALIBRATION PROCEDURE**

(Refer to Figure 2 and Table 1)

*Note: Connect pin 5 to ANALOG GROUND (pin 6) for operation without zero/offset adjustment. Connect pin 7 to ANALOG GROUND (pin 6) for operation without gain adjustment.*

Any offset and/or gain calibration procedures should not be implemented until devices are fully warmed up. To avoid interaction, offset must be adjusted before gain. The ranges of adjustment for the circuit in Figure 2 are guaranteed to compensate for the ADS-944's initial accuracy errors and may not be able to compensate for additional system errors.

A/D converters are calibrated by positioning their digital outputs exactly on the transition point between two adjacent digital output codes. This can be accomplished by connecting LED's to the digital outputs and adjusting until certain LED's "flicker" equally between on and off. Other approaches employ digital comparators or microcontrollers to detect when the outputs change from one code to the next.

For the ADS-944, offset adjusting is normally accomplished at the point where the MSB is a 1 and all other output bits are 0's and the LSB just changes from a 0 to a 1. This digital output transition ideally occurs when the applied analog input is  $+1/2$ LSB ( $+76.3\mu\text{V}$ ).

Gain adjusting is accomplished when all bits are 1's and the LSB just changes from a 1 to a 0. This transition ideally occurs when the analog input is at +full scale minus  $1 1/2$  LSB's ( $+1.249771$ ).

*Note: Due to inherent system noise, the averaging of several conversions may be needed to accurately adjust both offset and gain to 1LSB of accuracy.*

**Zero/Offset Adjust Procedure**

1. Apply a train of pulses to the START CONVERT input (pin 32) so the converter is continuously converting.
2. Apply  $+76.3\mu\text{V}$  to the ANALOG INPUT (pin 3).
3. Adjust the offset potentiometer until the output bits are 10 0000 0000 0000 and the LSB flickers between 0 and 1 with pin 8 tied low (offset binary) or between 01 1111 1111 1111 and 01 1111 1111 1110 with pin 8 tied high (complementary offset binary).
4. Two's complement coding requires using BIT 1 (MSB) (pin 31). With pin 8 tied low, adjust the trimpot until the code flickers between 00 0000 0000 0000 and 00 0000 0000 0001.

**Gain Adjust Procedure**

1. Apply  $+1.249771\text{V}$  to the ANALOG INPUT (pin 3).
2. Adjust the gain potentiometer until all output bits are 1's and the LSB flickers between 1 and 0 with pin 8 tied low (offset binary) or until all bits are 0's and the LSB flickers between 1 and 0 with pin 8 tied high (complementary offset binary).
3. Two's complement coding requires using pin 31. With pin 8 tied low, adjust the gain trimpot until the output code flickers equally between 01 1111 1111 1110 and 01 1111 1111 1111.
4. To confirm proper operation of the device, vary the applied input voltage to obtain the output coding listed in Table 1.

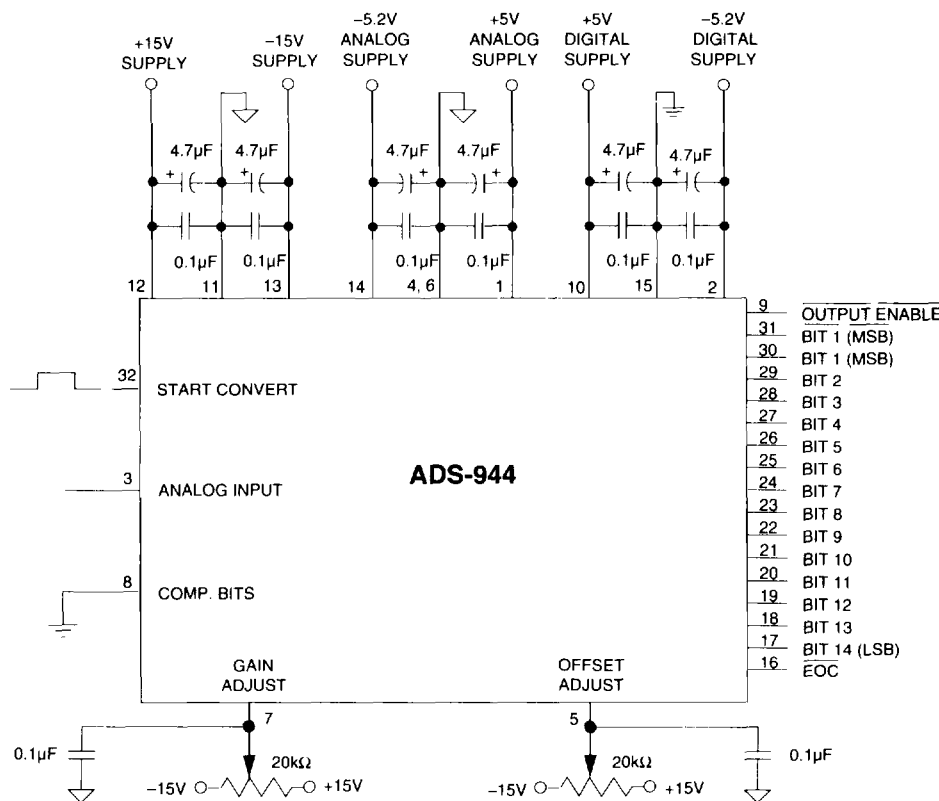

**Figure 2. ADS-944 Connection Diagram**

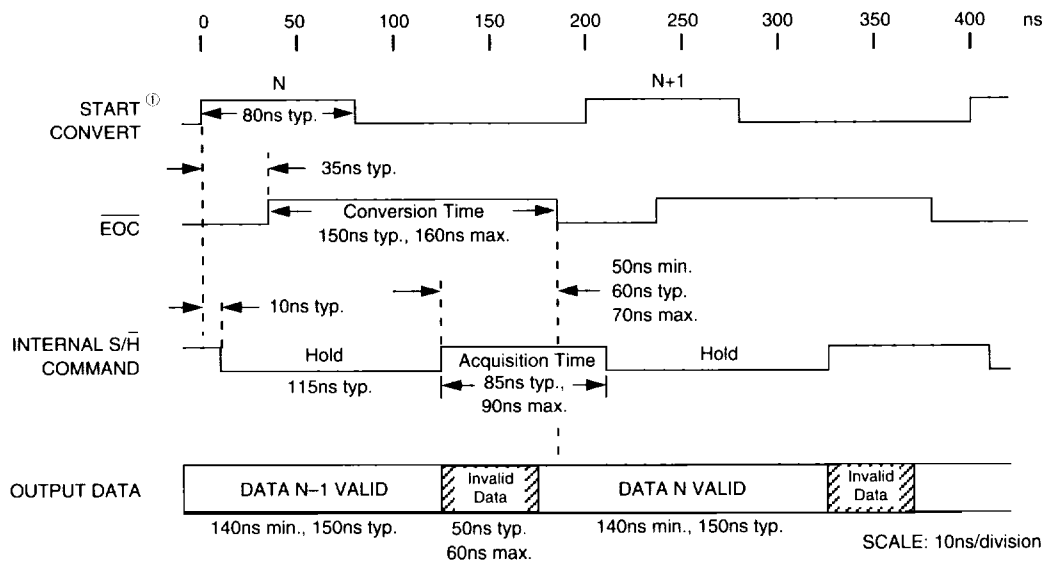

① START CONVERT pulse width: 40 to 80ns or 130 to 160ns

**Figure 3. ADS-944 Timing Diagram**

**TIMING**

The ADS-944 is an edge-triggered device. A conversion is initiated by the rising edge of the start convert pulse and no additional external timing signals are required. The device does not employ "pipeline" delays to increase its throughput rate. It does not require multiple start convert pulses to bring valid digital data to its output pins.

Approximately 10ns after the rising edge of the start convert signal, the ADS-944's internal sample-and-hold amplifier is driven into the hold mode by the internal S/H control line. After a 35ns delay to allow for S/H output transient settling, the conversion process begins, and the EOC line (pin 16) is driven high. The complete A/D conversion requires approximately 150ns. The falling of EOC signals that the conversion is now complete and digital output data is now valid.

This device actually guarantees that digital output data will be valid for 10ns prior to the falling edge of EOC. Therefore, EOC can be used to latch data into external registers that have appropriate setup times. Any other available timing edges, including a delayed EOC or the rising edge of the next EOC pulse, can also be used for this purpose.

The falling edge of the start convert pulse, though irrelevant to device timing, can cause conversion errors if it occurs at certain times. Therefore, the recommended start convert pulse width is between 40 and 80ns or between 130 and 160ns. DATEL performs ADS-944 production testing at the full 5MHz sampling rate using 80ns start convert pulses.

**THERMAL REQUIREMENTS**

All DATEL sampling A/D converters are fully characterized and specified over operating temperature (case) ranges of 0 to +70°C and -55 to +125°C. All room-temperature (T<sub>A</sub> = +25°C) production testing is performed without the use of heat sinks or forced-air cooling. Thermal impedance figures for each device are listed in their respective specification tables.

These devices do not normally require heat sinks, however, standard precautionary design and layout procedures should be used to ensure devices do not overheat. The ground and power planes beneath the package, as well as all pcb signal runs to and from the device, should be as heavy as possible to help conduct heat away from the package.

Electrically-insulating, thermally-conductive "pads" may be installed underneath the package. Devices should be soldered to boards rather than "socketed", and of course, minimal air flow over the surface can greatly help reduce the package temperature.

In more severe ambient conditions, the package/junction temperature of a given device can be reduced dramatically (typically 35%) by using one of DATEL's HS Series heat sinks. See Ordering Information for the assigned part number. See page 1-183 of the DATEL Data Acquisition Components Catalog for more information on the HS Series. Request DATEL Application Note AN-8, "Heat Sinks for DIP Data Converters", or contact DATEL directly, for additional information.

**Table 1. Output Coding**

OUTPUT CODING						INPUT RANGE ±1.25V	BIPOLAR SCALE
MSB	LSB	MSB	LSB	MSB	LSB		
11 1111 1111 1111	00 0000 0000 0000	01 1111 1111 1111	01 1111 1111 1111	+1.249847	+FS -1 LSB		
11 1000 0000 0000	00 0111 1111 1111	01 1000 0000 0000	01 1000 0000 0000	+0.937500	+3/4 FS		
11 0000 0000 0000	00 1111 1111 1111	01 0000 0000 0000	00 0000 0000 0000	+0.625000	+1/2 FS		
10 0000 0000 0000	01 1111 1111 1111	00 0000 0000 0000	00 0000 0000 0000	0.000000	0		
01 0000 0000 0000	10 1111 1111 1111	11 0000 0000 0000	11 0000 0000 0000	-0.625000	-1/2 FS		
00 1000 0000 0000	11 0111 1111 1111	10 1000 0000 0000	10 1000 0000 0000	-0.937500	-3/4 FS		
00 0000 0000 0001	11 1111 1111 1110	10 0000 0000 0001	10 0000 0000 0001	-1.249847	-FS +1 LSB		
00 0000 0000 0000	11 1111 1111 1111	10 0000 0000 0000	10 0000 0000 0000	-1.250000	-FS		
OFF. BINARY		COMP. OFF. BIN.		TWO'S COMP.			

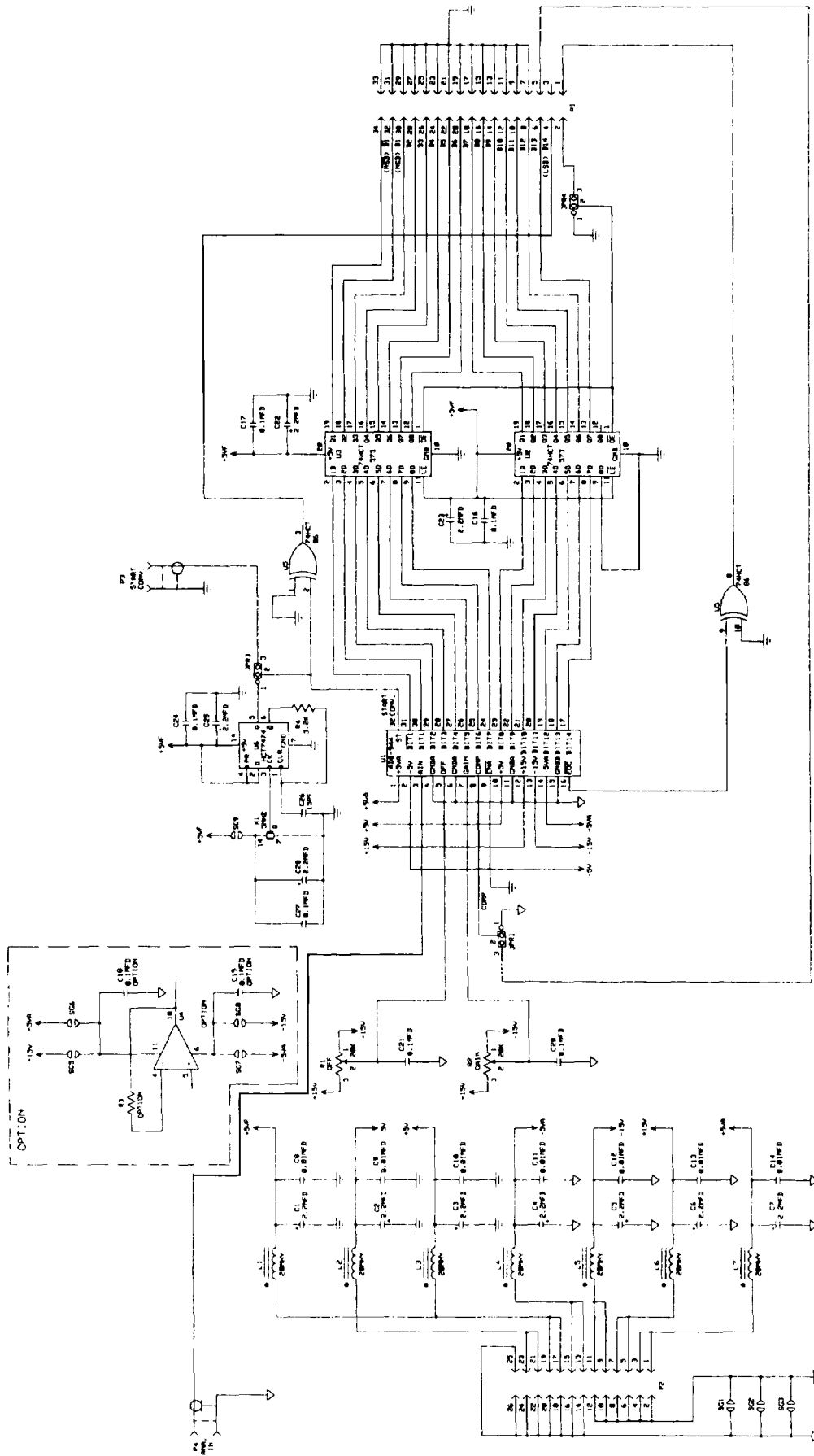

NOTES  
 1. UNLESS OTHERWISE SPECIFIED  
 ALL CAPACITORS ARE 50V  
 C1 - C6 ARE 20V  
 ALL RESISTORS ARE IN OHMS

Figure 4. ADS-944 Evaluation Board Schematic

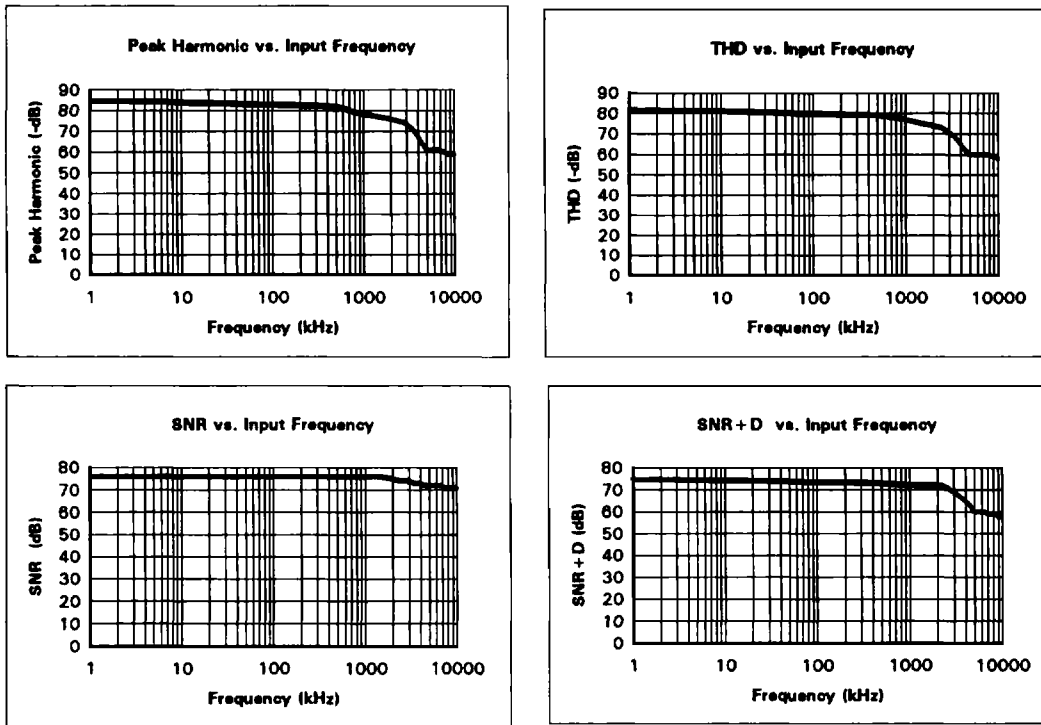

Figure 5. Typical ADS-944 Dynamic Performance vs. Input Frequency at +25°C

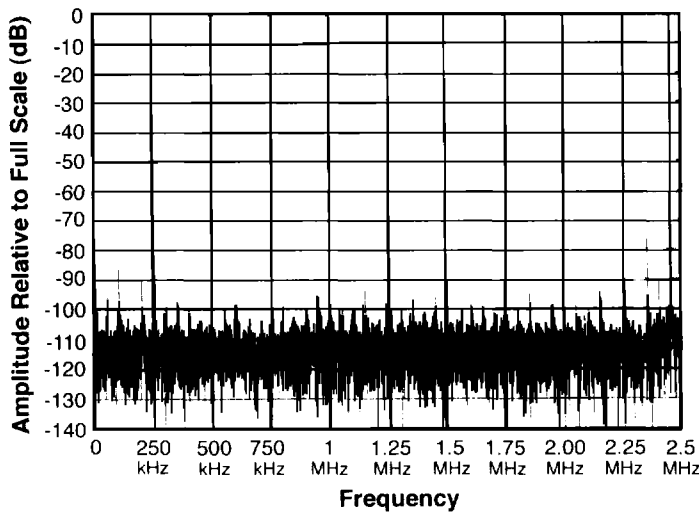

Figure 6. ADS-944 FFT  
( $f_{in} = 2.45\text{MHz}$ ,  $f_s = 5\text{MHz}$ ,  $V_{in} = -0.5\text{dB}$ , 16,384 points)

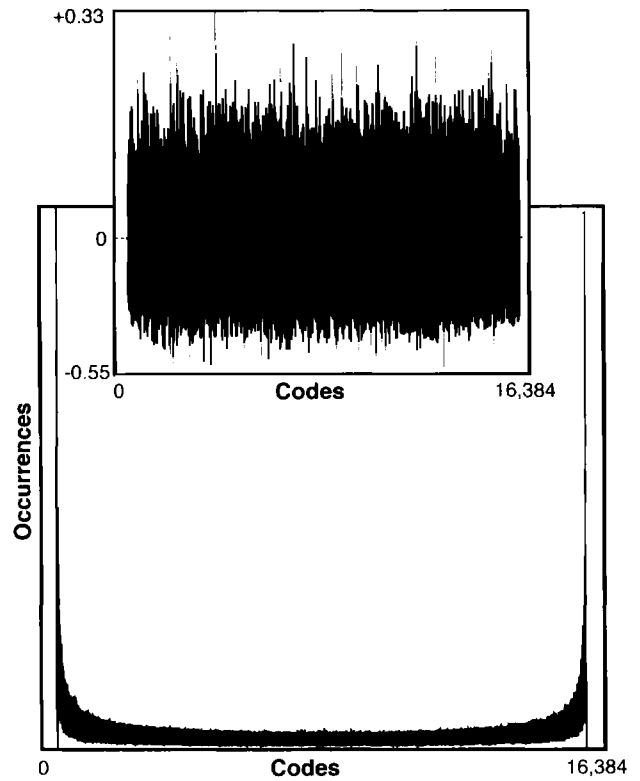

Figure 7. ADS-944 Histogram and Differential Nonlinearity

**MECHANICAL DIMENSIONS**  
INCHES (mm)

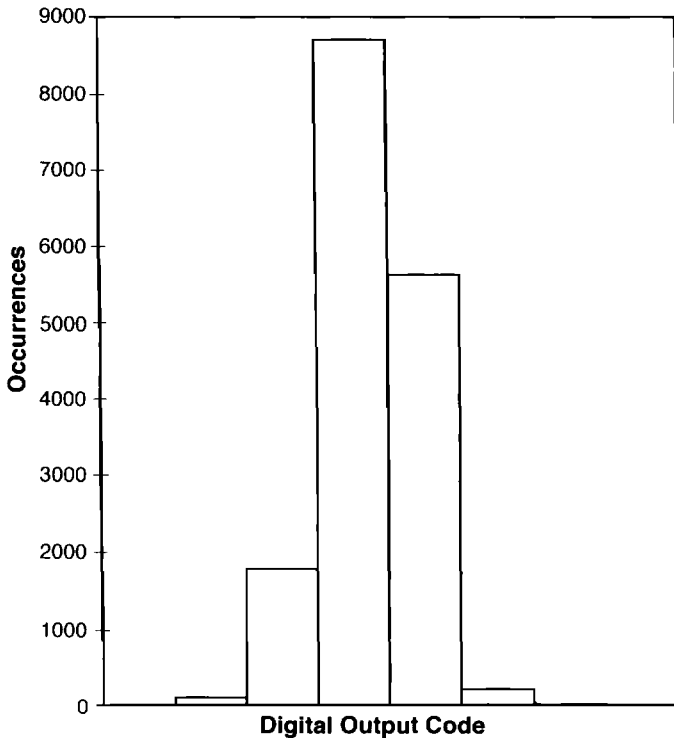
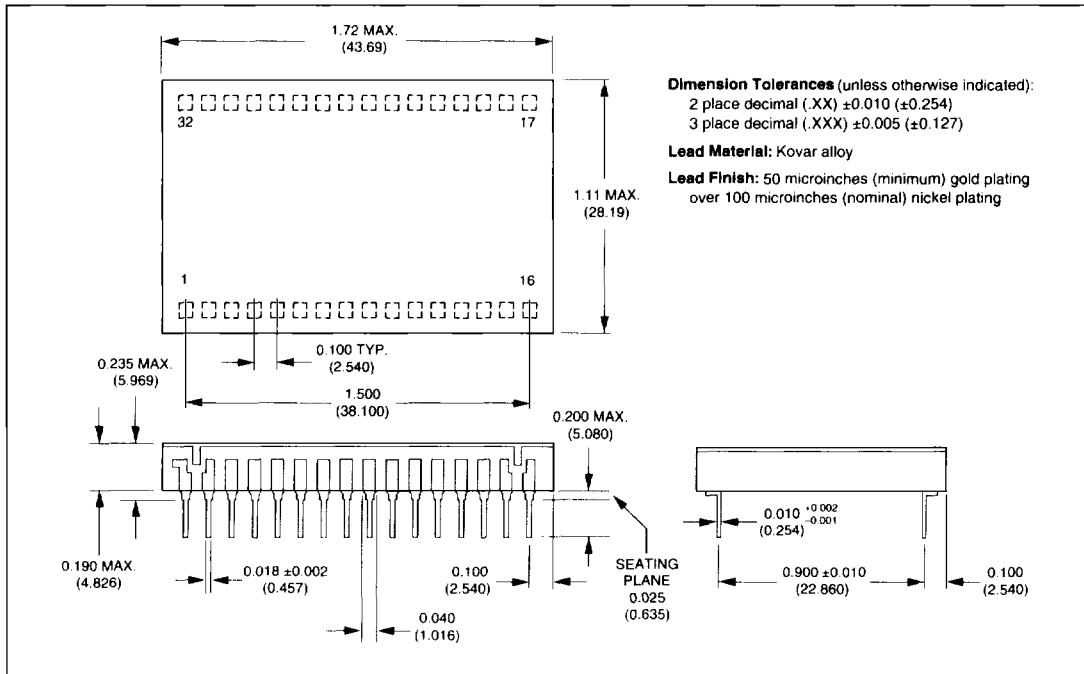

Figure 8. ADS-944 Grounded Input Histogram

The histogram in Figure 8 represents the typical peak-to-peak noise (including quantization noise) associated with the ADS-944. 16,384 conversions were processed with the input to the ADS-944 tied to analog ground.

**ORDERING INFORMATION**

MODEL NUMBER	OPERATING TEMP. RANGE
ADS-944MC	0 to +70°C
ADS-944MM	-55 to +125°C
ADS-944/883	-55 to +125°C

Contact DATEL for availability of surface-mount (J-lead) packaging or for MIL-STD-883 or DESC SMD product specifications.

**ACCESSORIES**

ADS-B944	Evaluation Board (without ADS-944)
HS-32	Heat sink for ADS-944 DDIP models

Receptacles for PC board mounting can be ordered through AMP Inc., Part # 3-331272-8 (Component Lead Socket), 24 required.