



PRELIMINARY SPECIFICATION

EEPROM AS8ERLC128K32

Austin Semiconductor, Inc.

128K x 32 Radiation Tolerant EEPROM

AVAILABLE AS MILITARY SPECIFICATIONS

- MIL-STD-883, para 1.2.1 compliant
- SPACE Level Process Flow

FEATURES

- Access time of 250ns , 300ns
- Operation with single **3.3V** ($\pm .3V$) supply
- LOW Power Dissipation:
 - Active(Worst case): **300mW** (MAX), Max Speed Operation
 - Standby(Worst case): **7.2mW**(MAX), Battery Back-up Mode
- Automatic Byte Write: 15 ms (MAX)
- Automatic Page Write (128 bytes): 15 ms (MAX)
- Data protection circuit on power -on/off
- Low power CMOS MONOS cell Technology
- 10^4 Erase/Write cycles (in Page Mode)
- Software data protection
- TTL Compatible Inputs and Outputs
- Data Retention: 10 years
- Ready/Busy\ and Data Polling Signals
- Write protection by RES\ pin
- Radiation Tolerant: Proven total dose 40K to 100K RADS*
- Shielded Package for Best Radiation Immunity
- Operating Temperature Ranges:
 - Military: -55°C to +125°C
 - Industrial: -40°C to +85°C

OPTIONS

- Timing
 - 150 ns
 - 200 ns
 - 250 ns
- Package
 - Ceramic Quad Flat pack w/ formed leads
 - Ceramic Quad Flat pack w/ tie bar
 - Shielded Ceramic Quad Flat pack
 - Shielded Ceramic Quad Flat pack

MARKINGS

-150	Q	No. 703Q
-200	QB	No. 703QB
-250	SQ	No. 703SF
	SQB	No. 703SQB

GENERAL DESCRIPTION

The Austin Semiconductor, Inc. AS8ERLC128K32 is a 4 Mega-bit Radiation Tolerant EEPROM Module organized as 128K x 32 bit. User configurable to 256K x 16 or 512Kx 8. The module achieves high speed access, low power consumption and high reliability by employing advanced CMOS memory technology.

The military grade product is manufactured in compliance to MIL-STD 883, making the AS8ERLC128K32 ideally suited for military or space applications.

The module is offered as a 68 lead 0.880 inch square ceramic quad flat pack. It has a max. height of 0.200 inch (non-shielded). This package design is targeted for those applications which require low profile SMT Packaging.

* contact factory for test reports. ASI does not guarantee or warrant these performance levels, but references these third party reports.

PIN ASSIGNMENT

(Top View)

68 Lead CQFP

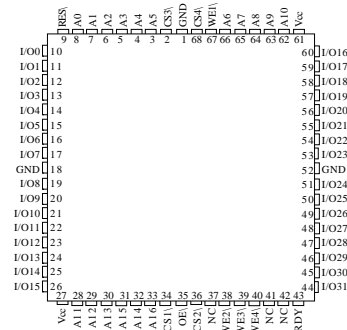

*Pin #'s 31 and 32, A15 and A14 respectively, are reversed from the AS8E128K32. Correct use of these address lines is required for operation of the SDP mode to work properly.

PIN NAME	FUNCTION
A0 to A16	Address Input
I/O0 to I/O31	Data Input/Output
OE\	Output Enable
CE\	Chip Enable
WE\	Write Enable
V _{cc}	Power Supply
V _{ss}	Ground
RDY/BUSY\	Ready Busy
RES\	Reset

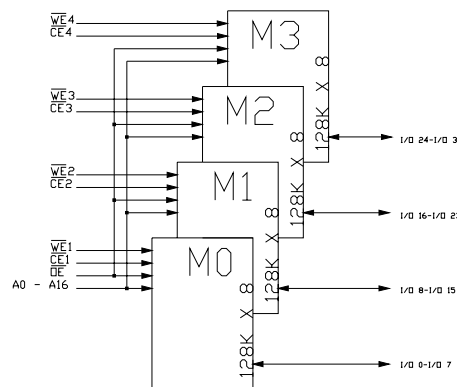

FUNCTIONAL BLOCK DIAGRAM

For more products and information please visit our web site at www.austinsemiconductor.com



**PRELIMINARY
SPECIFICATION**

Austin Semiconductor, Inc.

**EEPROM
AS8ERLC128K32**

TRUTH TABLE

MODE	CE\	OE\	WE\	RES\	RDY/BUSY ¹	I/O
Read	V _{IL}	V _{IL}	V _{IH}	V _H ²	High-Z	Dout
Standby	V _{IH}	X ³	X	X	High-Z	High-Z
Write	V _{IL}	V _{IH}	V _{IL}	V _H	High-Z to V _{OL}	Din
Deselect	V _{IL}	V _{IH}	V _{IH}	V _H	High-Z	High-Z
Write Inhibit	X	X	V _{IH}	X	---	---
	X	V _{IL}	X	X	---	---
Data\ Polling	V _{IL}	V _{IL}	V _{IH}	V _H	V _{OL}	Dout (I/O ⁷)
Program Reset	X	X	X	V _{IL}	High-Z	High-Z

- NOTES:** 1. RDY/Busy\ output has only active LOW V_{OL} and high impedance state. It can not go to HIGH (V_{OH}) state.
2. $V_{CC} - 0.5V \leq V_H \leq V_{CC} + 0.5V$
3. X : DON'T CARE



PRELIMINARY SPECIFICATION

EEPROM AS8ERLC128K32

Austin Semiconductor, Inc.

ABSOLUTE MAXIMUM RATINGS*

Voltage on Vcc Supply Relative to Vss

Vcc-0.6V to +5.0V

Operating Temperature Range⁽¹⁾-55°C to +125°C

Storage Temperature Range-65°C to +150°C

Voltage on any Pin Relative to Vss.....-0.5V to +5.0V⁽²⁾

Max Junction Temperature**.....+150°C

Thermal Resistance junction to case (θ_{JC}):

Package Type Q.....11.3°C/W

Package Type P & PN.....2.8°C/W

*Stresses greater than those listed under "Absolute Maximum Ratings" may cause permanent damage to the device. This is a stress rating only and functional operation of the device at these or any other conditions above those indicated in the operation section of this specification is not implied. Exposure to absolute maximum rating conditions for extended periods may affect reliability.

**Junction temperature depends upon package type, cycle time, loading, ambient temperature and airflow, and humidity (plastics).

NOTES:

- 1) Including electrical characteristics and data retention.
- 2) V_{IN} MIN = -1.0V for pulse width < 20ns.

ELECTRICAL CHARACTERISTICS AND RECOMMENDED DC OPERATING CONDITIONS

(-55°C ≤ T_A ≤ 125°C or -40°C to +85°C; V_{CC} = 3.3V +/- .3V)

PARAMETER	CONDITIONS	SYMBOL	MIN	MAX	UNITS
Input High Voltage		V _{IH}	2.2	V _{CC} +0.3	V
Input High Voltage (RES\)		V _H	V _{CC} -0.5	V _{CC} +.5	V
Input Low Voltage		V _{IL}	-0.3 ¹	0.8	V
LOW INPUT Leakage(RES\ Signal)	RES\=0V, VCC=3.6V	I _{LI} (RES)	-500		μA
HIGH INPUT Leakage(RES\ Signal)	RES\=3.6V, VCC=3.6V	I _{HI} (RES)		10	μA
INPUT LEAKAGE CURRENT ²	0V ≤ V _{IN} ≤ V _{CC}	I _{LI}	-10	10	μA
OUTPUT LEAKAGE CURRENT ²	Outputs(s) Disabled, 0V ≤ V _{OUT} ≤ V _{CC}	I _{LO}	-10	10	μA
Output High Voltage	I _{OH} = -0.4mA	V _{OH}	V _{CC} x.8	--	V
Output High Voltage	I _{OH} = -0.1mA	V _{OH}	V _{CC} -.0.3	--	V
Output Low Voltage	I _{OL} = 2.1mA	V _{OL}	--	0.4	V
Output Low Voltage	I _{OL} = 0.1mA	V _{OL}	--	0.2	V
Supply Voltage		V _{CC}	3	3.6	V

- NOTE:** 1) V_{IL} (MIN): -1.0V for pulse width < 20ns.
2) All other Signal pins except RES\

PARAMETER	CONDITIONS	SYM	MAX	MAX	UNITS
			-250	-300	
Power Supply Current: Operating	I _{out} = 0mA, V _{CC} = 3.6V Cycle = 1μS, Duty = 100%	I _{CC3}	30	30	mA
	I _{out} = 0mA, V _{CC} = 3.6V Cycle = MIN, Duty = 100%		80	70	
Power Supply Current: Standby	CE\ = V _{CC} , V _{CC} = 3.6V	I _{CC1}	0.2	0.2	mA
	CE\ = V _{IH} , V _{CC} = 3.6V	I _{CC2}	4	4	mA

CAPACITANCE TABLE¹ ($V_{IN} = 0V, f = 1\text{ MHz}, T_A = 25^\circ C, V_{CC} = 3.3V$)

SYMBOL	PARAMETER	MAX	UNITS
C_{ADD}	A0 - A16 Capacitance	40	pF
C_{OE}	OE\, RES\, RDY Capacitance	40	pF
C_{WE}, C_{CE}	WE\ and CE\ Capacitance	12	pF
C_{IO}	I/O 0- I/O 31 Capacitance	20	pF

NOTE: 1. This parameter is guaranteed but not tested.

AC TEST CHARACTERISTICS

TEST SPECIFICATIONS

Input pulse levels..... V_{SS} to 3V
 Input rise and fall times.....5ns
 Input timing reference levels.....1.5V
 Output reference levels.....1.5V
 Output load.....See Figure 1

NOTES:

V_z is programmable from -2V to +5V.
 I_{OL} and I_{OH} programmable from 0 to 16 mA.
 V_z is typically the midpoint of V_{OH} and V_{OL} .
 I_{OL} and I_{OH} are adjusted to simulate a typical resistive load circuit.

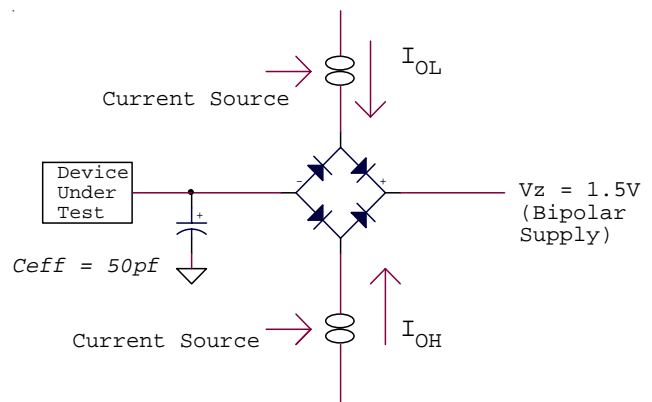

Figure 1

ELECTRICAL CHARACTERISTICS AND RECOMMENDED AC OPERATING CONDITIONS

($-55^\circ C \leq T_A \leq +125^\circ C$ or $-40^\circ C$ to $+85^\circ C$; $V_{CC} = 3.3V \pm 0.3V$)

DESCRIPTION	TEST CONDITIONS	SYMBOL	-250		-300		UNITS
			MIN	MAX	MIN	MAX	
Address to Output Delay	CE\ = OE\ = V_{IL} , WE\ = V_{IH}	t_{ACC}		250		300	ns
CE\ to Output Delay	OE\ = V_{IL} , WE\ = V_{IH}	t_{CE}		250		300	ns
OE\ to Output Delay	OE\ = V_{IL} , WE\ = V_{IH}	t_{OE}	10	120	10	130	ns
Address to Output Hold	CE\ = OE\ = V_{IL} , WE\ = V_{IH}	t_{OH}	0		0		ns
CE\ or OE\ high to Output Float (1)	OE\ = V_{IL} , WE\ = V_{IH}	t_{DF}	0	50	0	50	ns
RES\ low to Output Float (1)	CE\ = OE\ = V_{IL} , WE\ = V_{IH}	t_{DFR}	0	350	0	350	ns
RES\ to Output Delay	CE\ = OE\ = V_{IL} , WE\ = V_{IH}	t_{RR}	0	600	0	600	ns



**PRELIMINARY
SPECIFICATION**

Austin Semiconductor, Inc.

**EEPROM
AS8ERLC128K32**

ELECTRICAL CHARACTERISTICS AND RECOMMENDED AC WRITE CHARACTERISTICS

($-55^{\circ}\text{C} \leq T_A \leq +125^{\circ}\text{C}$; $V_{CC} = 3.3\text{V} \pm .3\text{V}$)

SYMBOL	PARAMETER	MIN ⁽²⁾	MAX	UNITS
t_{AS}	Address Setup Time	0		ms
t_{AH}	Address Hold Time	150		ns
t_{CS}	CE\ to Write Setup Time (WE\ controlled)	0		ns
t_{CH}	CE\ Hold Time (WE\ controlled)	0		ns
t_{WS}	WE\ to Write Setup Time (CE\ controlled)	0		ns
t_{WH}	WE\ to Hold Time (CE\ controlled)	0		ns
t_{OES}	OE\ to Write Setup Time	0		ns
t_{OEH}	OE\ to Hold Time	0		ns
t_{DS}	Data Setup Time	100		ns
t_{DH}	Data Hold Time	10		ns
t_{WP}	WE\ Pulse Width (WE\ controlled)	250		ns
t_{CW}	CE\ Pulse Width (CE\ controlled)	250		ns
t_{DL}	Data Latch Time	750		ns
t_{BLC}	Byte Load Cycle	1	30	μs
t_{BL}	Byte Load Window	100		μs
t_{WC}	Write Cycle Time		15 ⁽³⁾	ms
t_{DB}	Time to Device Busy	150		ns
t_{DW}	Write Start Time	250 ⁽⁴⁾		ns
t_{RP}	Reset Protect Time	100		μs
t_{RES}	Reset High Time ⁽⁵⁾	2		μs

READ TIMING WAVEFORM

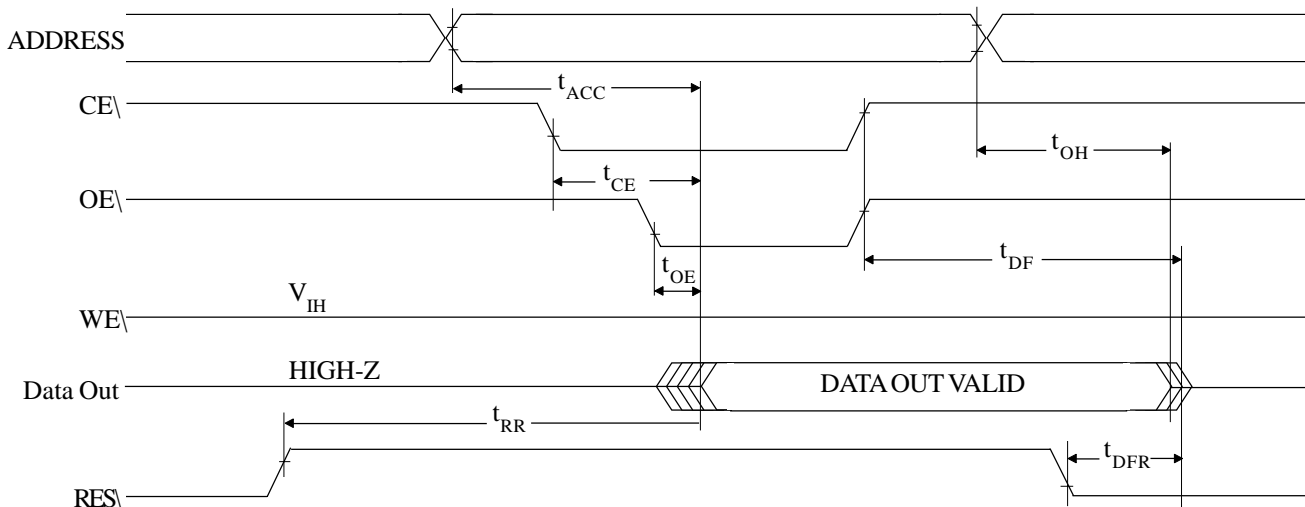

BYTE WRITE TIMING WAVEFORM (WE\ CONTROLLED)

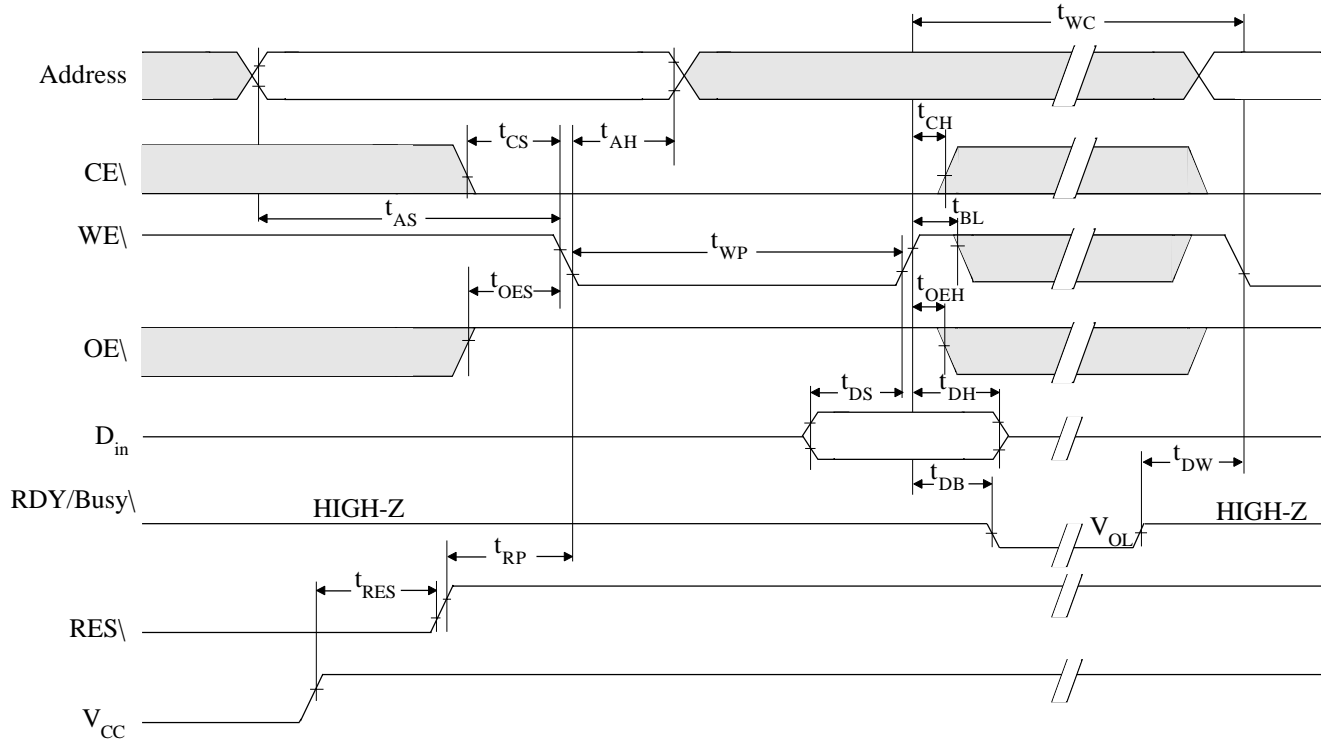

BYTE WRITE TIMING WAVEFORM (CE\ CONTROLLED)

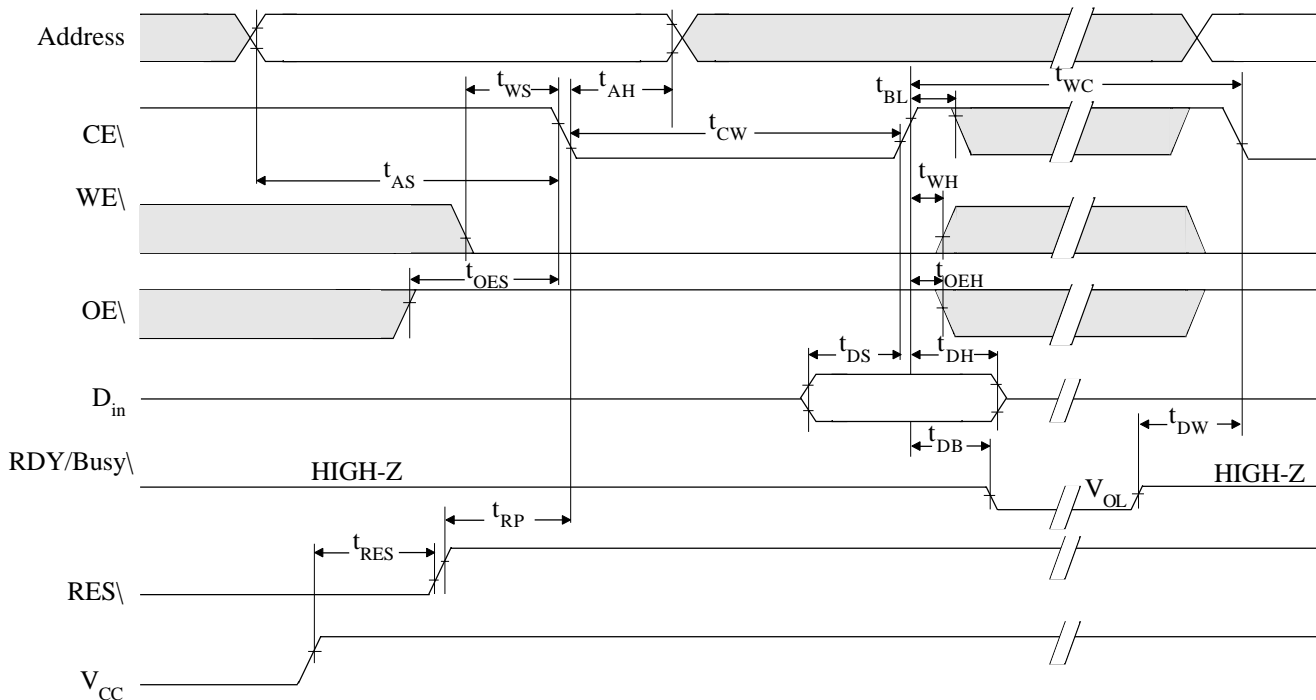

PAGE WRITE TIMING WAVEFORM (WE\ CONTROLLED)

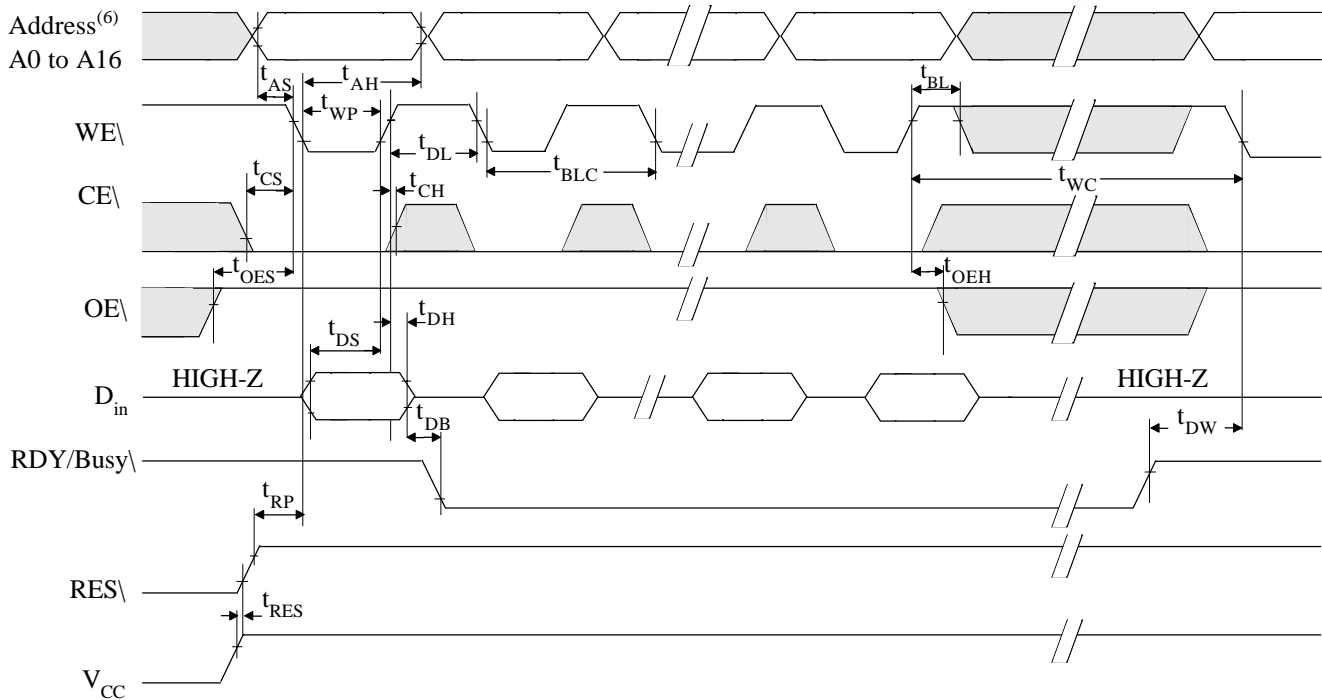

PAGE WRITE TIMING WAVEFORM (CE\ CONTROLLED)

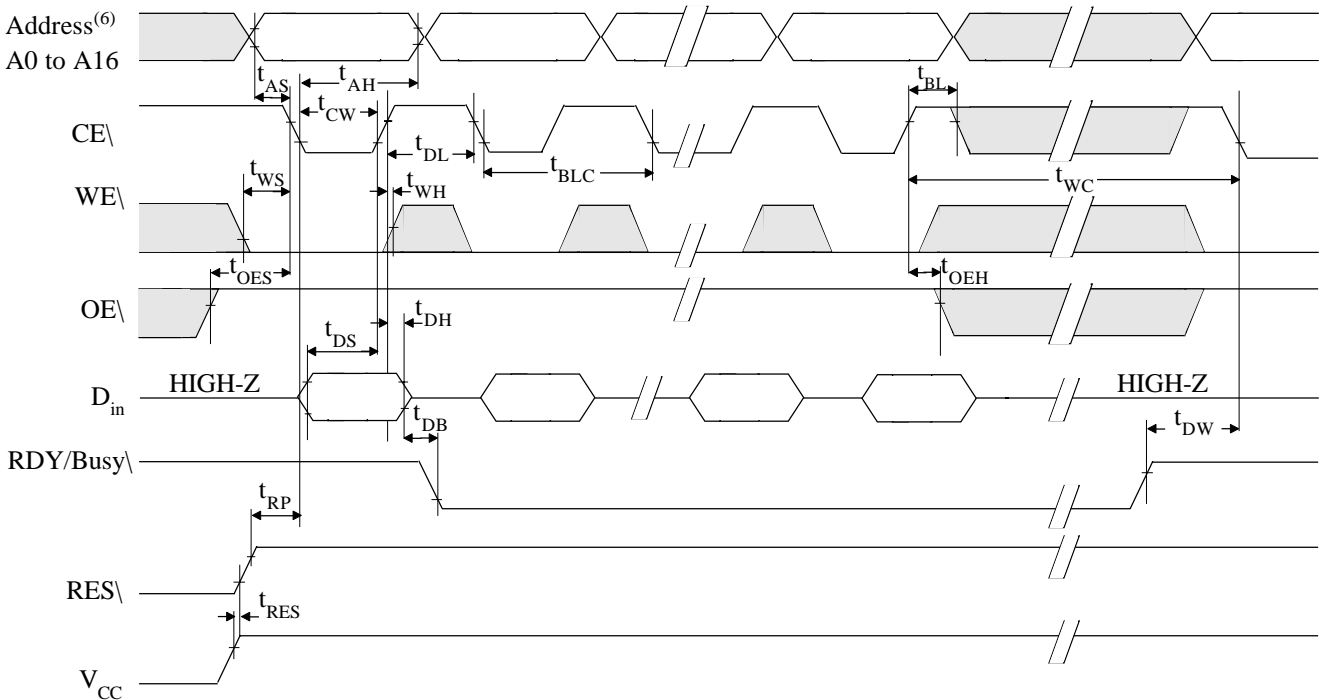

DATA POLLING TIMING WAVEFORM

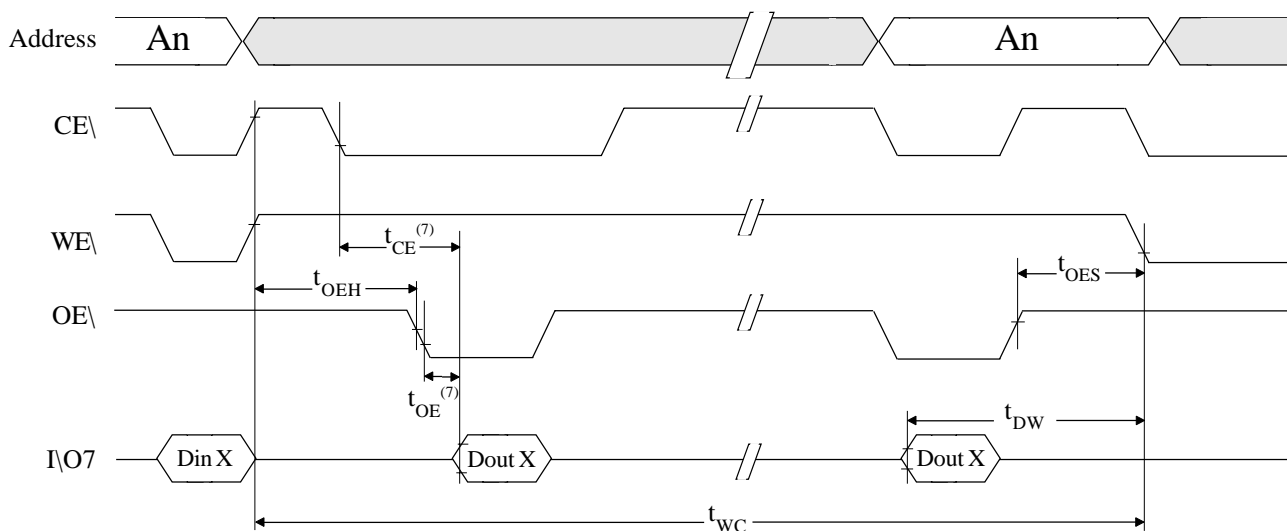

NOTES:

1. t_{DF} and t_{DFR} are defined as the time at which the outputs achieve the open circuit conditions and are no longer driven.
2. Use this device in longer cycle than this value.
3. t_{WC} must be longer than this value unless polling techniques or RDY/Busy\ are used. This device automatically completes the internal write operation within this value.
4. Next read or write operation can be initiated after t_{DW} if polling techniques or RDY/Busy\ are used.
5. This parameter is sampled and not 100% tested.
6. A7 to A16 are page addresses and must be same (i.e. Not Change) during the page write operation.
7. See AC read characteristics.

TOGGLE BIT

This device provides another function to determine the internal programming cycle. If the EEPROM is set to read mode during the internal programming cycle, I/O6 will charge from "1" to "0" (toggling) for each read. When the internal programming cycle is finished, toggling of I/O6 will stop and the device can be accessible for next read or program.

TOGGLE BIT WAVEFORM

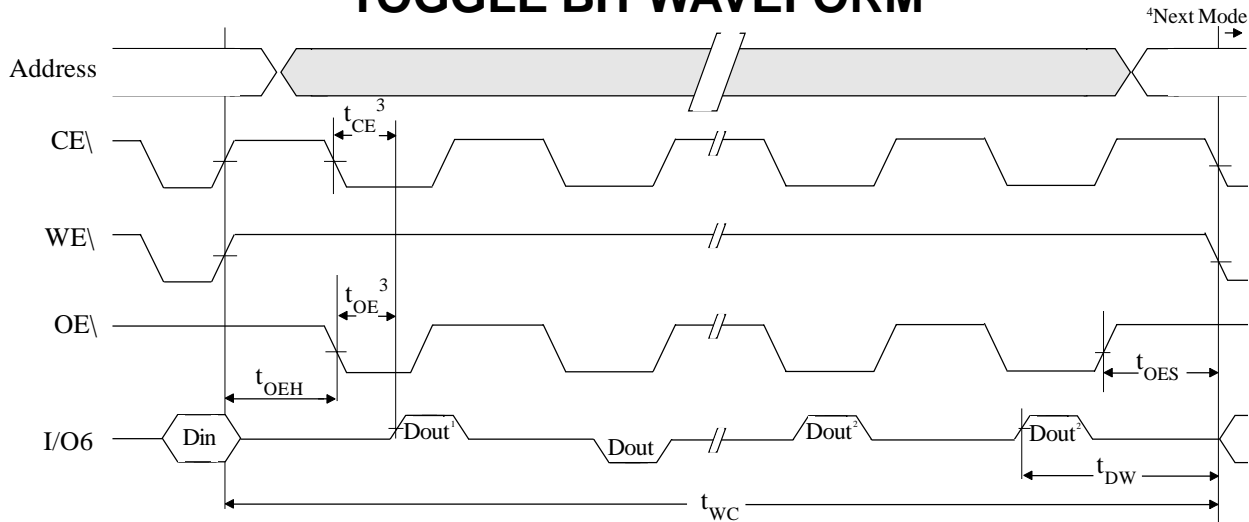

NOTES:

- 1) I/O6 beginning state is "1".
- 2) I/O6 ending state will vary.
- 3) See AC read characteristics.
- 4) Any locations can be used, but the address must be fixed.

SOFTWARE DATA PROTECTION TIMING WAVEFORM (In protection mode)

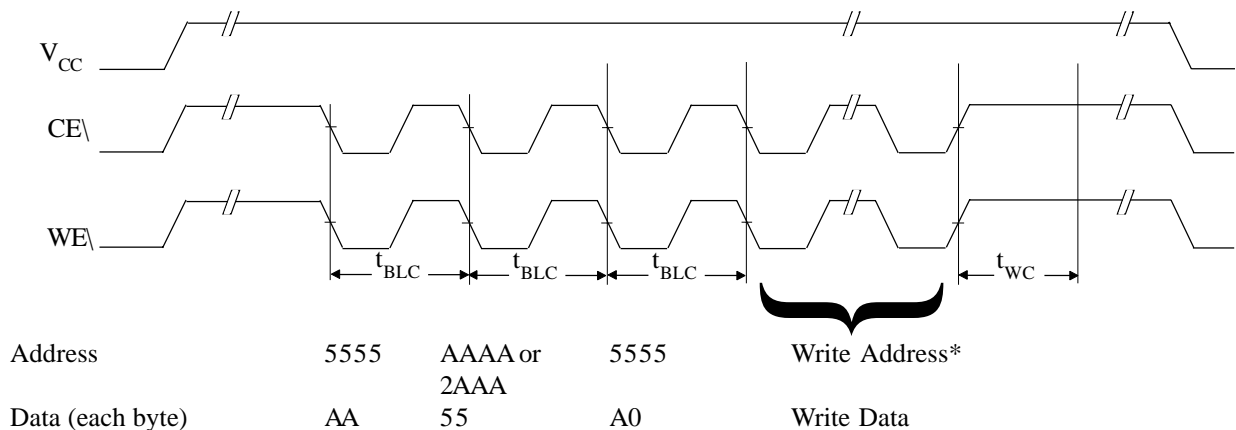

* During this write cycle, data is physically written to the address provided.

SOFTWARE DATA PROTECTION TIMING WAVEFORM (In non-protection mode)

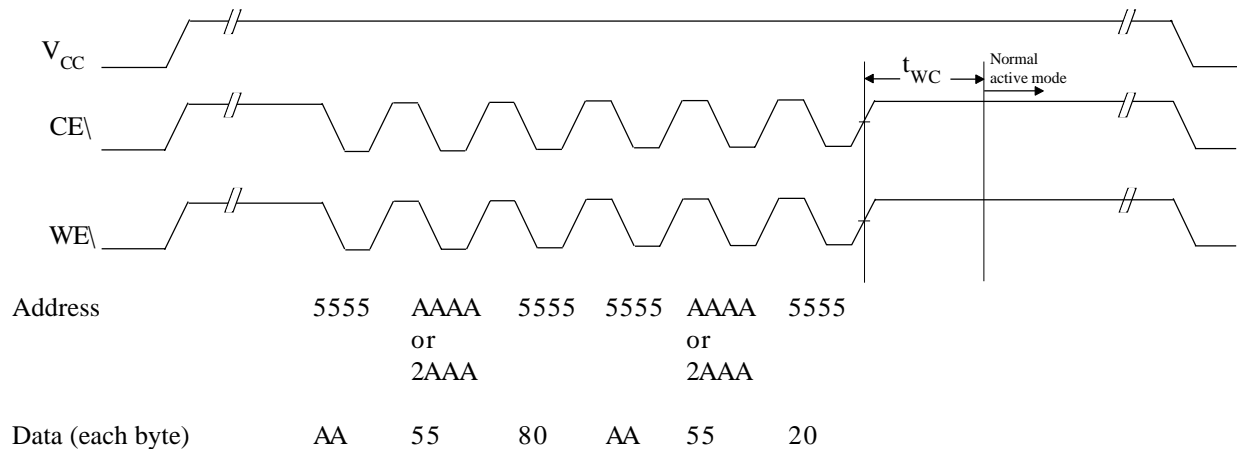

FUNCTIONAL DESCRIPTION

Automatic Page Write

Page-mode write feature allows 1 to 128 bytes of data to be written into the EEPROM in a single write cycle. Following the initial byte cycle, an additional 1 to 128 bytes can be written in the same manner. Each additional byte load cycle must be started within 30µs from the preceding falling edge of WE\ or CE\. When CE\ or WE\ is kept high for 100µs after data input, the EEPROM enters write mode automatically and the input data are written into the EEPROM.

DATA\ Polling

DATA\ polling allows the status of the EEPROM to be determined. If EEPROM is set to read mode during the write cycle, an inversion of the last byte of data to be loaded outputs from I/O's 7, 15, 23, and 31 to indicate that the EEPROM is performing a write operation.

RDY/Busy\ Signal

RDY/Busy\ signal also allows status of the EEPROM to be determined. The RDY/Busy\ signal has high impedance except in write cycle and is lowered to V_{OL} after the first write signal. At the end of write cycle, the RDY/Busy\ signal changes state to high impedance.

RES\ Signal

When RES\ is low, the EEPROM cannot be read or programmed. Therefore, data can be protected by keeping RES\ low when V_{CC} is switched. RES\ should be high during read and programming because it doesn't provide a latch function. See timing diagram below.

RES\ Signal Diagram

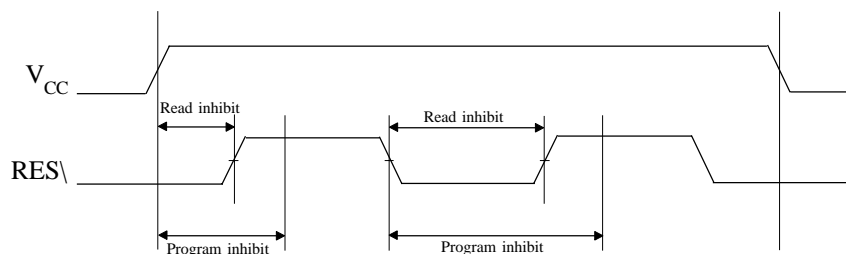

WE\, CE\ Pin Operation

During a write cycle, address are latched by the falling edge of WE\ or CE\, and data is latched by the rising edge of WE\ or CE\.

Write/Erase Endurance and Data Retention Time

The endurance is 10^4 cycles in case of the page programming and 10^3 cycles in case of the byte programming (1% cumulative failure rate). The data retention time is more than 10 years when a device is page-programmed less than 10^4 cycles.

RDY/Busy\ SIGNAL

RDY/Busy\ signal also allows status of the EEPROM to be determined. The RDY/Busy\ signal has high impedance except in write cycle and is lowered to V_{OL} after the first write signal. At the end of the write cycle, the RDY/Busy\ signal changes state to high impedance. This allows many AS8ERLC128K32 devices RDY/Busy\ signal lines to be wired-OR together.

PROGRAMMING/ERASE

The AS8ERLC128K32 does **NOT** employ a BULK-erase function. The memory cells can be programmed '0' or '1'. A write cycle performs the function of erase & write on every cycle with the erase being transparent to the user. The internal erase data state is considered to be '1'. To program the memory array with background of ALL 0's or All 1's, the user would program this data using the page mode write operation to program all 1024 128-byte pages.

Data Protection

1. Data Protection against Noise on Control Pins (CE\, OE\, WE\) During Operation

During readout or standby, noise on the control pins

may act as a trigger and turn the EEPROM to programming mode by mistake. To prevent this phenomenon, this device has a noise cancellation function that cuts noise if its width is 20ns or less in program mode.

Be careful not to allow noise of a width more than 20ns on the control pins. See Diagram 1 below.

2. Data Protection at V_{CC} On/Off

When V_{CC} is turned on or off, noise on the control pins generated by external circuits (CPU, etc.) may act as a trigger and turn the EEPROM to program mode by mistake. To prevent this unintentional programming, the EEPROM must be kept in an unprogrammable state while the CPR is in an unstable state.

NOTE: The EEPROM should be kept in unprogrammable state during V_{CC} on/off by using CPU RESET signal. See the timing diagram below.

DIAGRAM 1

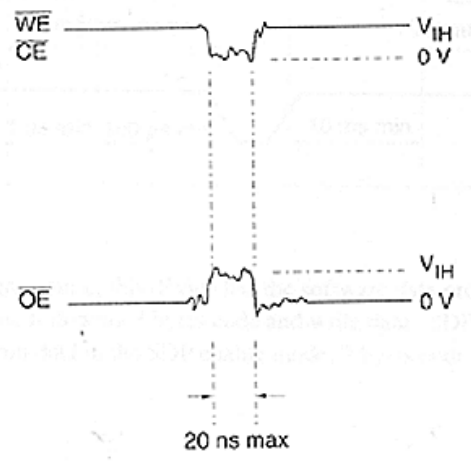

DATA PROTECTION AT V_{CC} ON/OFF

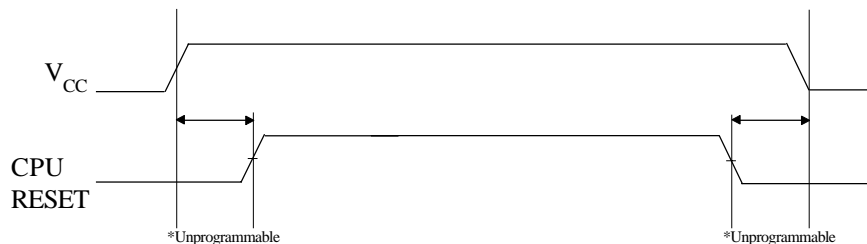

Data Protection Cont.

a. *Protection by RES*

The unprogrammable state can be realized by the CPU's reset signal inputs directly to the EEPROM's RES pin. RES should be kept V_{SS} level during V_{CC} on/off.

The EEPROM brakes off programming operation when RES becomes low, programming operation doesn't finish correctly in case that RES falls low during programming operation. RES should be kept high for 10ms after the last data inputs. See the timing diagram below.

3. *Software data protection*

To prevent unintentional programming, this device has the software data protection (SDP) mode. The SDP is enabled by inputting the 3 bytes code and write data in Chart 1. SDP is not enabled if only the 3 bytes code is input.

To program data in the SDP enable mode, 3 bytes code must be input before write data. This 4th cycle during write is required to initiate the SDP and physically writes the address and data. While in SDP the entire array is protected in which writes can only occur if the exact SDP sequence is re-executed or the unprotect sequence is executed.

The SDP is disabled by inputting the 6 bytes code in Chart 2. Note that, if data is input in the SDP disable cycle, data can not be written.

The software data protection is not enabled at the shipment.

NOTE: These are some differences between ASI's and other company's for enable/disable sequence of software data protection. If these are any questions, please contact ASI.

PROTECTION BY RES

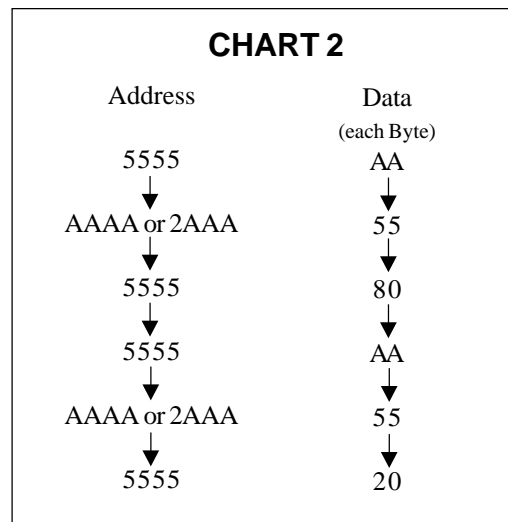
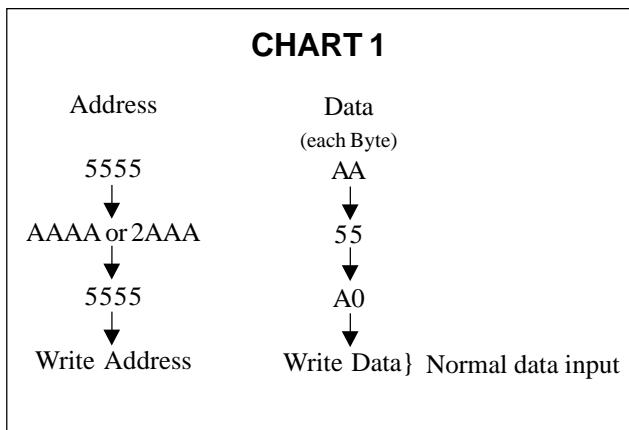
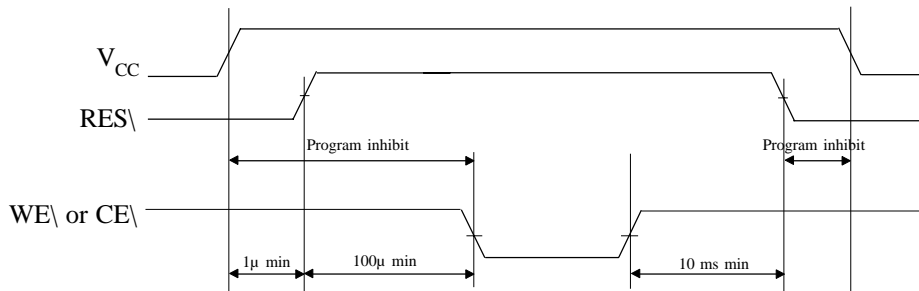

MECHANICAL DEFINITIONS*

ASI Case #703 (Package Designator Q)

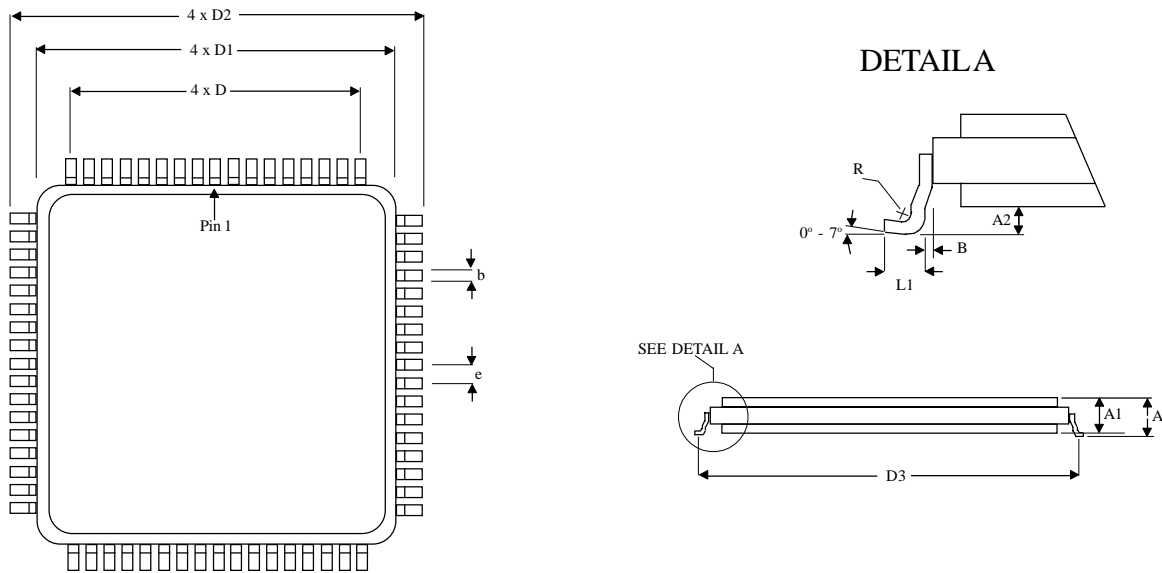

SYMBOL	ASI PACKAGE SPECIFICATIONS	
	MIN	MAX
A	0.123	0.200
A1	0.118	0.186
A2	0.000	0.020
b	0.013	0.017
B	0.010 REF	
D	0.800 BSC	
D1	0.870	0.890
D2	0.980	1.000
D3	0.936	0.956
e	0.050 BSC	
R	0.005	
L1	0.035	0.045

*All measurements are in inches.

MECHANICAL DEFINITIONS*

ASI Case #703SQ

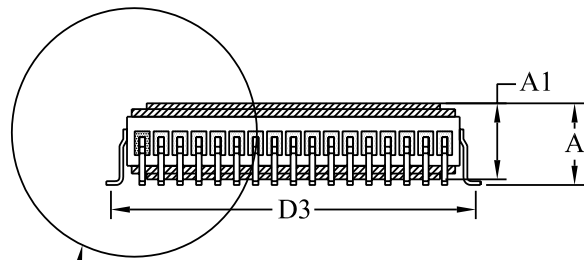
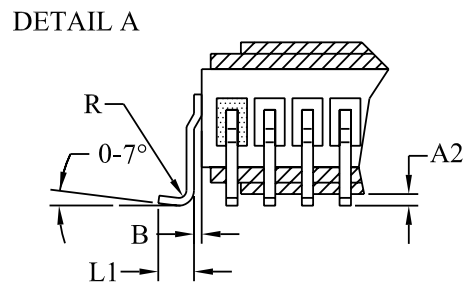
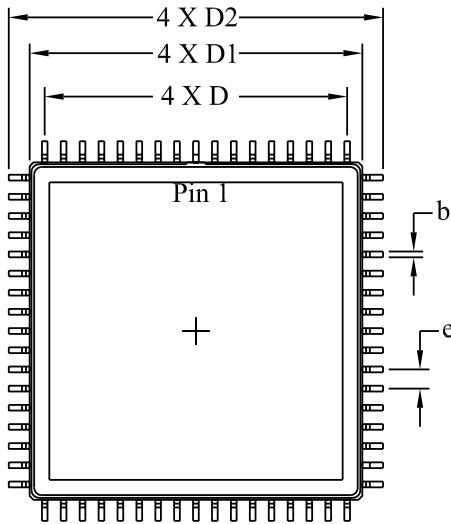

See Detail A

ASI PACKAGE SPECIFICATIONS		
SYMBOL	MIN	MAX
A	.190	.235
A1	.180	.220
A2	.005	.020
b	.013	.017
B	.010 REF	
D	.800 BSC	
D1	.870	.890
D2	.980	1.00
D3	.930	.960
e	.050 BSC	
R	.005	
L1	.035	.045
All Dimensions in inches		

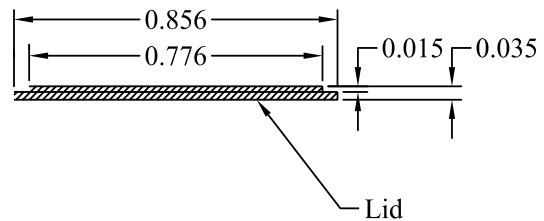

Note: 35 Mil Tungsten alloy lid on each side for improved TID radiation performance.

MECHANICAL DEFINITIONS*

ASI Case #703SQB

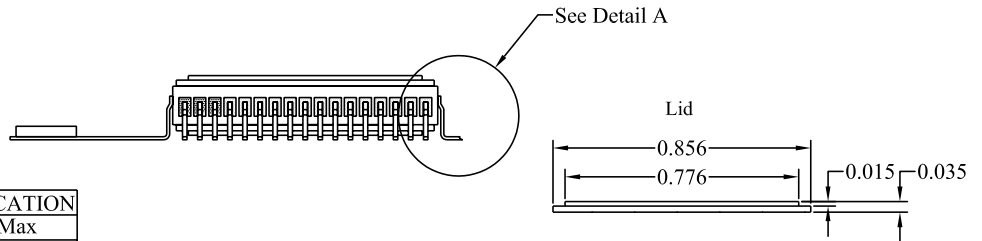
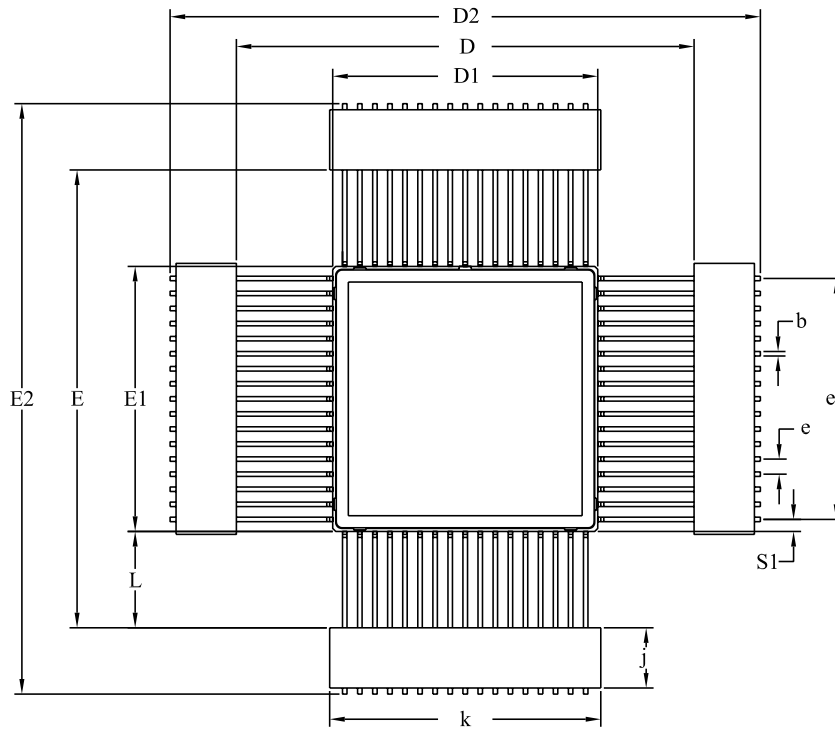

ASI PACKAGE SPECIFICATION		
Symbol	Min	Max
A		.235
A1	.180	.220
A2	.005	.020
b	.013	.017
D/E	1.500	1.540
D1/E1	.870	.890
D2/E2	1.920	2.000
e	.050 BSC	
e1	.800 BSC	
j	.190	.210
k	.890	.910
L	.310	.330
S1	.040 BSC	
Dimensions in inches		

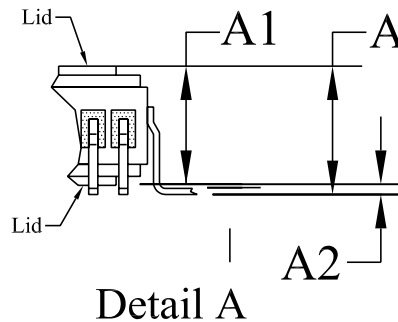

Note: 35 Mil Tungsten alloy lid on each side for improved TID radiation performance.

MECHANICAL DEFINITIONS*

ASI Case (Package Designator QB)

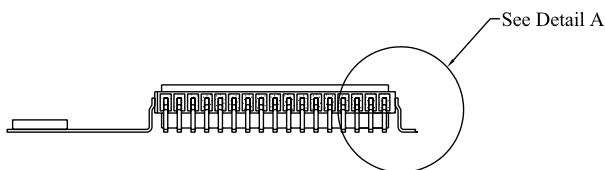
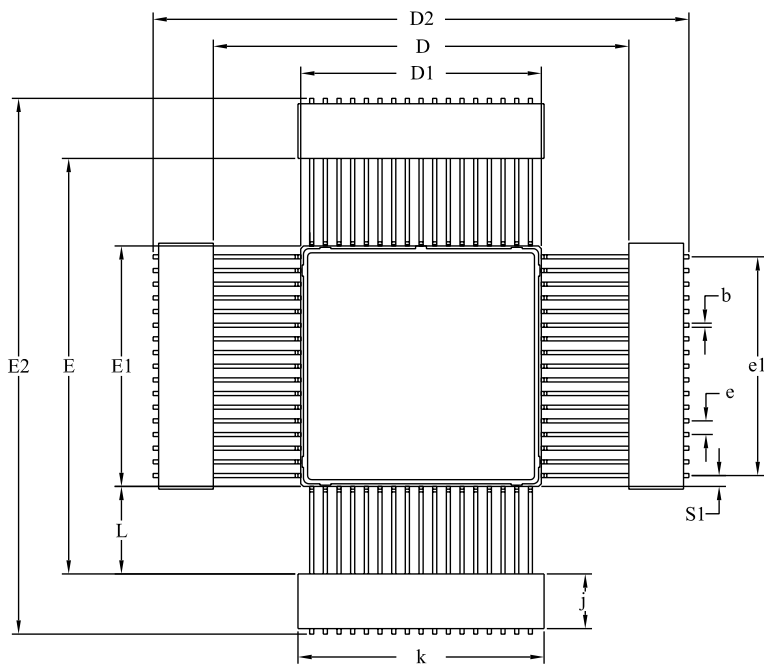

ASI PACKAGE SPECIFICATION		
Symbol	Min	Max
A	.157	.190
A1	.142	.175
A2	.005	.020
b	.013	.017
c	.009	.012
D/E	1.500	1.540
D1/E1	.870	.890
D2/E2	1.920	2.000
e	.050 BSC	
e1	.800 BSC	
j	.190	.210
k	.890	.910
L	.310	.330
S1	.040 BSC	
Dimensions in inches		

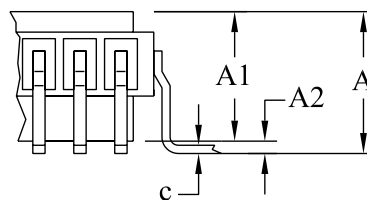

Detail A

*All measurements are in inches.



**PRELIMINARY
SPECIFICATION**

Austin Semiconductor, Inc.

**EEPROM
AS8ERLC128K32**

ORDERING INFORMATION

EXAMPLE: AS8ERLC128K32Q-250/883C
AS8ERLC128K32QB-300/SPACE

Device Number	Package Type	Speed ns	Process
AS8ERLC128K32	Q	-250	/*
AS8ERLC128K32	Q	-300	/*
AS8ERLC128K32	QB	-250	/*
AS8ERLC128K32	QB	-300	/*
AS8ERLC128K32	SQ	-250	/*
AS8ERLC128K32	SQ	-300	/*
AS8ERLC128K32	SQB	-250	/*
AS8ERLC128K32	SQB	-300	/*

***AVAILABLE PROCESSES**

IT = Industrial Temperature Range -40°C to +85°C
XT = Extended Temperature Range -55°C to +125°C
883C = Full Military Processing, 1.2.1 compliant -55°C to +125°C
SPACE = ASI Class 'S' Flow -55°C to +125°C



**PRELIMINARY
SPECIFICATION**

**EEPROM
AS8ERLC128K32**

Austin Semiconductor, Inc.

**ASI TO DSCC PART NUMBER
CROSS REFERENCE***

Package Designator Q

<u>ASI Part #</u>	<u>SMD Part</u>
AS8ERLC128K32Q-250/883C	to be determined
AS8ERLC128K32Q-300/883C	to be determined

Package Designator QB

<u>ASI Part #</u>	<u>SMD Part</u>
AS8ERLC128K32QB-250/883C	to be determined
AS8ERLC128K32QB-300/883C	to be determined

* ASI part number is for reference only. Orders received referencing the SMD part number will be processed per the SMD.